

**PA13NA  
PA13PA**

**13 SEER Split–System Air Conditioner  
With R–410A Refrigerant  
Single & Three Phase  
1–1/2 To 5 Tons**

## Product Data



### FEATURES AND BENEFITS

#### AVAILABLE SIZES:

Nominal sizes are available from 018 through 060 to meet the needs of residential and light commercial applications.

#### CERTIFICATION:

All models are listed with UL, (U.S. and Canada), AHRI, and CEC.

#### ELECTRICAL RANGE:

Units offered in single phase 208/230v are 018-060, and three phase 208/230v in 036, 048 and 060.

#### FAN MOTOR:

The totally enclosed fan motor provides greater reliability under adverse conditions and dependable performance for many years. The permanent split capacitor type motor was designed for optimum efficiency. The motor was then qualified under extreme conditions to help ensure a long, reliable life.

#### CABINET:

A weather protective cabinet of prepainted steel is protected underneath by a galvanized coating and treated with a layer of zinc phosphate for a finish that will last for many years. All screws on cabinet exterior are coated for a long-lasting, rust-resistant, quality appearance.

#### UNIT DESIGN:

The copper tube, enhanced sine wave, aluminum fin coil is designed for optimum heat transfer. Vertical air discharge carries sound and hot condenser air up and away from adjacent patio areas and foliage. The base pan is designed for easy removal of water, dirt, and leaves.

#### COMPRESSOR:

Each compressor is protected with internal temperature- and current-sensitive overloads. An internal pressure relief valve provides high pressure protection to the refrigerant system. For improved serviceability, all models are equipped with a compressor terminal plug.

#### SERVICE VALVES:

Both service valves are brass, front seating type with sweat connections. Valves are externally located so refrigerant tube connections can be made quickly and easily. Each valve has a service port for ease of checking operating refrigerant pressures.

#### SERVICEABILITY:

One access panel provides access to electrical controls. Removal of top gives access to fan motor, compressor, and condenser coil.

# PRODUCT NUMBER NOMENCLATURE

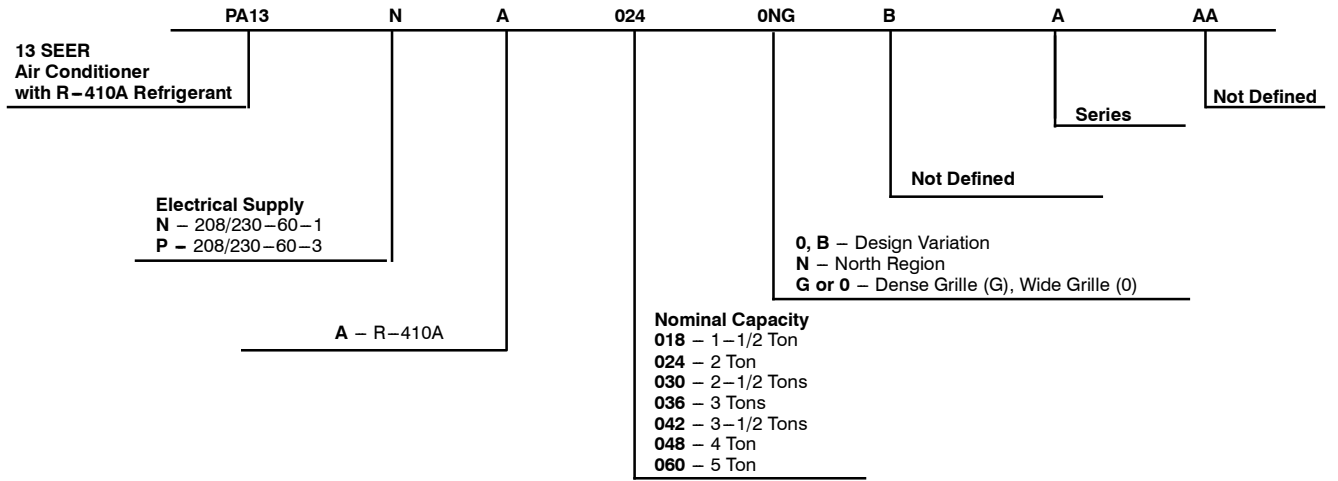

Use of the AHRI Certified TM Mark indicates a manufacturer's participation in the program. For verification of certification for individual products, go to [www.ahridirectory.org](http://www.ahridirectory.org).



ISO 9001  
QMI-SAI Global



# REFRIGERANT PIPING LENGTH LIMITATIONS

## Liquid Line Sizing and Maximum Total Equivalent Lengths† for Cooling Only Systems with R-410A Refrigerant:

The maximum allowable length of a residential split system depends on the liquid line diameter and vertical separation between indoor and outdoor units.

See Table below for liquid line sizing and maximum lengths :

### Maximum Total Equivalent Length Outdoor Unit BELOW Indoor Unit

Size	Liquid Line Connection	Liquid Line Diam. w/ TXV	AC with R-410A Refrigerant Maximum Total Equivalent Length†: Outdoor unit BELOW Indoor Vertical Separation ft (m)								
			0-5 (0-1.5)	6-10 (1.8-3.0)	11-20 (3.4-6.1)	21-30 (6.4-9.1)	31-40 (9.4-12.2)	41-50 (12.5-15.2)	51-60 (15.5-18.3)	61-70 (18.6-21.3)	71-80 (21.6-24.4)
			018	3/8	1/4	150	150	125	100	100	75
5/16	250*	250*	250*		250*	250*	250*	250*	225*	150	
3/8	250*	250*	250*		250*	250*	250*	250*	250*	250*	
024	3/8	1/4	75	75	75	50	50	--	--	--	--
		5/16	250*	250*	250*	250*	250*	225*	175	125	100
		3/8	250*	250*	250*	250*	250*	250*	250*	250*	250*
030	3/8	1/4	30	--	--	--	--	--	--	--	--
		5/16	175	225*	200	175	125	100	75	--	--
		3/8	250*	250*	250*	250*	250*	250*	250*	250*	250*
036	3/8	5/16	175	150	150	100	100	100	75	--	--
		3/8	250*	250*	250*	250*	250*	250*	250*	250*	250*
042	3/8	5/16	125	100	100	75	75	50	--	--	--
		3/8	250*	250*	250*	250*	250*	250*	250*	250*	150
048	3/8	3/8	250*	250*	250*	250*	250*	250*	230	160	--
060	3/8	3/8	250*	250*	250*	225*	190	150	110	--	--

\* Maximum actual length not to exceed 200 ft (61 m)

† Total equivalent length accounts for losses due to elbows or fitting. See the Long Line Guideline for details.

-- = outside acceptable range

### Maximum Total Equivalent Length Outdoor Unit ABOVE Indoor Unit

Size	Liquid Line Connection	Liquid Line Diam. w/ TXV	AC with R-410A Refrigerant Maximum Total Equivalent Length†: Outdoor unit ABOVE Indoor Vertical Separation ft (m)							
			25 (7.6)	26-50 (7.9-15.2)	51-75 (15.5-22.9)	76-100 (23.2-30.5)	101-125 (30.8-38.1)	126-150 (38.4-45.7)	151-175 (46.0-53.3)	176-200 (53.6-61.0)
			018	3/8	1/4	175	250*	250*	250*	250*
5/16	250*	250*			250*	250*	250*	250*	250*	250*
3/8	250*	250*			250*	250*	250*	250*	250*	250*
024	3/8	1/4	100	125	175	200	225*	250*	250*	250*
		5/16	250*	250*	250*	250*	250*	250*	250*	250*
		3/8	250*	250*	250*	250*	250*	250*	250*	250*
030	3/8	1/4	30	--	--	--	--	--	--	--
		5/16	250*	250*	250*	250*	250*	250*	250*	250*
		3/8	250*	250*	250*	250*	250*	250*	250*	250*
036	3/8	5/16	225*	250*	250*	250*	250*	250*	250*	250*
		3/8	250*	250*	250*	250*	250*	250*	250*	250*
042	3/8	5/16	175	200	250*	250*	250*	250*	250*	250*
		3/8	250*	250*	250*	250*	250*	250*	250*	250*
048	3/8	3/8	250*	250*	250*	250*	250*	250*	250*	250*
060	3/8	3/8	250*	250*	250*	250*	250*	250*	250*	250*

\* Maximum actual length not to exceed 200 ft (61 m)

† Total equivalent length accounts for losses due to elbows or fitting. See the Long Line Guideline for details.

-- = outside acceptable range

## REFRIGERANT CHARGE ADJUSTMENTS

Liquid Line Size	R-410A Charge oz/ft (g/m)
3/8	0.60 (17.74) (Factory charge for lineset = 9 oz / 266.16 g)
5/16	0.40 (11.83)
1/4	0.27 (7.98)

Units are factory charged for 15 ft (4.6 m) of 3/8" liquid line\*. The factory charge for 3/8" lineset 9 oz. When using other length or diameter liquid lines, charge adjustments are required per the chart above.

### Charging Formula:

[(Lineset oz/ft x total length) – (factory charge for lineset)] = charge adjustment

**Example 1:** System has 15 ft of line set\* using existing 1/4" liquid line. What charge adjustment is required?

Formula: (.27 oz/ft x 15ft) – (9 oz) = (-4.95) oz.

Net result is to remove 4.95 oz of refrigerant from the system

**Example 2:** System has 45 ft of existing 5/16" liquid line. What is the charge adjustment?

Formula: (.40 oz/ft. x 45ft) – (9 oz.) = 9 oz.

Net result is to add 9 oz of refrigerant to the system

**NOTE:** Conditions must be favorable for charging by subcooling method. Indoor temperature must be 70°F to 80°F (21.1°C to 26.7°C), and outdoor temperature must be 70°F to 100°F (21.1°C to 37.8°C). If outside these conditions, adjust charge for long line sets by weigh-in method.

\* When applicable. Refer to Physical Data Table in this PD and to the Installation Instructions for more information.

## LONG LINE APPLICATIONS

An application is considered Long Line, when the refrigerant level in the system requires the use of accessories to maintain acceptable refrigerant management for systems reliability. See Accessory Usage Guideline table for required accessories. Defining a system as long line depends on the liquid line diameter, actual length of the tubing, and vertical separation between the indoor and outdoor units.

For Air Conditioner systems, the chart below shows when an application is considered Long Line.

### AC with R-410A Refrigerant Long Line Description ft (m) Beyond these lengths, a TXV is required

Total Length	Outdoor Unit Above or Below Indoor Unit
TXV required beyond 50 ft. (15.2 m)	TXV required beyond 20 ft. (6.1 m)

### AC with R-410A Refrigerant Long Line Description ft (m) (Beyond these lengths, long line accessories are required)

Liquid Line Size	Units On Same Level	Outdoor Below Indoor	Outdoor Above Indoor
1/4 + TXV	No accessories needed within allowed lengths	No accessories needed within allowed lengths	175 (53.3)
5/16 + TXV	120 (36.6)	50 (15.2) vertical or 120 (36.6) total	120 (36.6)
3/8 + TXV	80 (24.4)	35 (10.7) vertical or 80 (24.4) total	80 (24.4)

**Note:** See Residential Piping and Long Line Guideline for details

## VAPOR LINE SIZING AND COOLING CAPACITY LOSS

Acceptable vapor line diameters provide adequate oil return to the compressor while avoiding excessive capacity loss. The suction line diameters shown in the chart below are acceptable for AC systems with R-410A refrigerant:

### Vapor Line Sizing and Cooling Capacity Losses — R-410A Refrigerant 1-Stage Air Conditioner Applications

Unit Nominal Size (Btuh)	Maximum Liquid Line Diameters (In. OD)	Vapor Line Diameters (In. OD)	Cooling Capacity Loss (%)								
			Total Equivalent Line Length ft. (m)								
			1-Stage AC with R-410A								
			26-50 (7.9-15.2)	51-80 (15.5-24.4)	81-100 (24.7-30.5)	101-125 (30.8-38.1)	126-150 (38.4-45.7)	151-175 (46.0-53.3)	176-200 (53.6-61.0)	201-225 (61.3-68.6)	226-250 (68.9-76.2)
018	3/8	1/2	1	2	3	5	6	7	8	9	11
		5/8	0	1	1	1	2	2	2	3	3
		3/4	0	0	0	0	1	1	1	1	1
024	3/8	5/8	0	1	2	2	3	3	4	5	5
		3/4	0	0	1	1	1	1	1	2	2
		7/8	0	0	0	0	0	1	1	1	1
030	3/8	5/8	1	2	3	3	4	5	6	7	8
		3/4	0	0	1	1	1	2	2	2	3
		7/8	0	0	0	0	1	1	1	1	1
036	3/8	5/8	1	2	4	5	6	8	9	10	12
		3/4	0	1	1	2	2	3	3	4	4
		7/8	0	0	0	1	1	1	1	2	2
042	3/8	3/4	0	1	2	2	3	4	4	5	6
		7/8	0	0	1	1	1	2	2	2	3
		1 1/8	0	0	0	0	0	0	0	0	0
048	3/8	3/4	0	1	2	3	4	5	5	6	7
		7/8	0	0	1	1	2	2	2	3	3
		1 1/8	0	0	0	0	0	0	0	0	1
060	3/8	3/4	1	2	4	5	6	7	9	10	11
		7/8	0	1	2	2	3	4	4	5	5
		1 1/8	0	0	0	1	1	1	1	1	1

Applications in this area may be long line and may have height restrictions. See the Residential Piping and Long Line Guideline.

# SPECIFICATIONS

UNIT SIZE	018		024		030		036			042		048		060										
SERIES	G		H		D		E		F		B		G		D		E		B					
<b>ELECTRICAL</b>																								
Unit Volts—Hertz—Phase	208/230—60—1				208/230—60—1				208/230—60—1		208/230—60—1		208/230—60—3		208/230—60—1		208/230—60—1		208/230—60—3		208/230—60—1		208/230—60—3	
Operating Voltage Range*	197—253										187—253		197—253		187—253		197—253		187—253		187—253			
Compressor—Rated Load Amps	9.0		10.9		12.8		14.1		13.6		9.0		16.6		18.3		13.1		22.1		16.0			
Locked Rotor Amps	48.0		62.9		67.8		70.0		79.0		71.0		85.0		93.0		83.1		125.0		110.0			
Condenser Fan Motor— Full Load Amps	0.5		0.7		0.6		1.4		1.1		1.4		1.1		1.4		1.4		1.4		1.4			
Max Branch Circuit Fuse Size†	20		25		25		30		30		20		35		40		30		50		30			
<b>COMPRESSOR AND REFRIGERANT</b>																								
Type	Scroll																							
Temperature and Current Protection	Internal Line Break																							
R—410A Refrigerant— Factory Charge Lb (kg) @ 15 ft (4.6 m)	3.15 (1.43)		3.15 (1.43)		4.30 (1.95)		4.67 (2.12)		5.42 (2.46)		4.67 (2.12)		6.07 (2.76)		7.10 (3.22)		7.00 (3.18)		8.80 (3.99)		8.00 (3.63)			
R—410A Refrigerant— Required Charge Lb (kg) @ 15 ft (4.6 m)‡	4.20 (1.91)		4.17 (1.89)		4.90 (2.22)		5.36 (2.43)		--		5.36 (2.43)		--		8.20 (3.72)		8.20 (3.72)		--		--			
Refrigerant Tubes (In. OD)	3/4 and 3/8				7/8 and 3/8				7/8 and 3/8				1—1/8 and 3/8											
<b>CONDENSER COIL AND FAN</b>																								
Coil Face Area (Sq Ft)	8.40		8.40		11.49		12.60		12.93		12.60		17.25		19.40		15.09							
Fan Motor—HP, Type, and RPM	1/12 PSC and 1100		1/10 PSC and 1100		1/4 PSC and 1100		1/5 PSC and 1100		1/4 PSC and 1100		1/5 PSC and 1100		1/4 PSC and 1100		1/5 PSC and 1100		1/4 PSC and 1100							
Volts—Hertz—Phase	208/230—60—1				208/230—60—1				208/230—60—1				208/230—60—1				208/230—60—1							
Condenser Airflow (CFM)	1700		2218		2169		2500		3310		2500		3000		3400		3400							
Fins Per Inch	20		25		25		20		20		20		25		25		20							
<b>OPTIONAL EQUIPMENT</b>																								
Cycle Protector	KSACY0101AAA																							
Start Assist—PTC Type	KAACS0201PTC				N/A				KAACS0201PTC				N/A				KAACS0201PTC				N/A			
Start Assist—Capacitor/Relay Type	KSAHS1501AAA				N/A				KSAHS1501AAA				N/A				KSAHS1501AAA				N/A			
MotorMaster® Control	KSALA0601AAA																							
Ball Bearing Fan Motor (RCD)	Standard				HC40GR232				Standard				HC40GR232				Standard							
Low—Pressure Switch	KAALP0401PUR																							
High—Pressure Switch	KAAHI0501PUR																							
Compressor Sound Hood	KSASH2501COP				KSASH2301COP				KSASH2501COP				KSASH2301COP				KSASH2401COP							
Time—Delay Relay	KAATD0101TDR																							
Low—Ambient Pressure Switch Kit	KSALA0301410																							
Winter Start Control	KAAWS0101AAA																							
Evaporator Freeze Thermostat	KSAFT0101AAA																							
Compressor Crankcase Heater	KAACH1401AAA										KAACH1201AAA													
Liquid Line Solenoid Valve††	KAALS0201LLS																							
TXV (Hard Shutoff)††	KSATX0201PUR				KSATX0301PUR				KSATX0401PUR				KSATX0501PUR											
TXV (Hard Shutoff)††	KSBTX0201PUR				KSBTX0301PUR				KSBTX0401PUR															
Liquid Line Filter Drier	KH43LG073																							

\* Permissible limits of the voltage range at which unit will operate satisfactorily. Operation outside these limits may result in unit failure.

† Time—delay fuse or circuit breaker.

‡ For 15 ft. Line set

“—” = Factory charge and required charge values are equal

\*\* Units are rated with 25 ft (7.6 m) of lineset length. See *Vapor Line Sizing and Cooling Capacity Loss* table when using other sizes and lengths of lineset.

†† Do not use hard shutoff TXV with liquid solenoid valve.

N/A – Not applicable in this application.

# ACCESSORY USAGE GUIDELINE

ACCESSORY	REQUIRED FOR LOW-AMBIENT COOLING APPLICATIONS (Below 55°F/12.8°C)	REQUIRED FOR LONG LINE APPLICATIONS*	REQUIRED FOR SEA COAST APPLICATIONS (Within 2 miles/3.22 km)
Ball Bearing Fan Motor	Yes†	No	No
Compressor Start Assist Capacitor and Relay	Yes	Yes	No
Crankcase Heater	Yes	Yes	No
Evaporator Freeze Thermostat	Yes	No	No
Hard Shut-Off TXV	Yes	Yes	Yes
Liquid Line Solenoid Valve	No	No	No
Motor Master® Control or Low-ambient Pressure Switch	Yes	No	No
Support Feet	Recommended	No	Recommended
Winter Start Control	Yes #	No	No

\* For tubing set lengths between 80 and 200 ft. (24.38 and 60.96 m) horizontal or 35 ft. (10.7 m) vertical differential (total equivalent length), refer to the Residential Split-System Longline Application Guideline.

† Required for Low-Ambient Controller (full modulation feature) MotorMaster® Control. Standard on all models except 575V, 3-phase units.

# Required if Low Pressure Switch is factory or field installed.

## Accessory Description and Usage (Listed Alphabetically)

### 1. Ball-Bearing Fan Motor

A fan motor with ball bearings which permits speed reduction while maintaining bearing lubrication.

Usage Guideline:

Required on all units when MotorMaster® is used.

### 2. Compressor Start Assist - Capacitor and Relay

Start capacitor and relay gives a "hard" boost to compressor motor at each start up.

Usage Guideline:

Required for reciprocating compressors in the following applications:

- Long line
- Low ambient cooling
- Hard shut off expansion valve on indoor coil
- Liquid line solenoid on indoor coil

Required for single-phase scroll compressors in the following applications:

- Long line
- Low ambient cooling

Suggested for all compressors in areas with a history of low voltage problems.

### 3. Crankcase Heater

An electric resistance heater which mounts to the base of the compressor to keep the lubricant warm during off cycles. Improves compressor lubrication on restart and minimizes the chance of liquid slugging.

Usage Guideline:

- Required in low ambient cooling applications.
- Required in long line applications.
- Suggested in all commercial applications.

### 4. Cycle Protector

The cycle protector is designed to prevent compressor short cycling. This control provides an approximate 5-minute delay after power to the compressor has been interrupted for any reason, including power outage, protector control trip, thermostat jiggling, or normal cycling.

### 5. Evaporator Freeze Thermostat

An SPST temperature-actuated switch that stops unit operation when evaporator reaches freeze-up conditions.

Usage Guideline:

Required when low ambient kit has been added.

### 6. Low-Ambient Pressure Switch Kit

A long life pressure switch which is mounted to outdoor unit service valve. It is designed to cycle the outdoor fan motor in order to maintain head pressure within normal operating limits (approximately 100 psig to 225 psig). The control will maintain working head pressure at low-ambient temperatures down to 0°F (-18°C) when properly installed.

Usage Guideline:

A Low-Ambient Pressure Switch or MotorMaster® Low-Ambient Controller must be used when cooling operation is used at outdoor temperatures below 55°F (12.8°C).

### 7. MotorMaster® Low-Ambient Controller

A fan-speed control device activated by a temperature sensor, designed to control condenser fan motor speed in response to the saturated, condensing temperature during operation in cooling mode only. For outdoor temperatures down to -10°F (-23°C), it maintains condensing temperature at 100°F ±10°F (37.8°C ± 5.5°C).

Usage Guideline:

A MotorMaster® Low Ambient Controller or Low-Ambient Pressure Switch must be used when cooling operation is used at outdoor temperatures below 55°F (12.8°C).

Suggested for all commercial applications.

### 8. Outdoor Air Temperature Sensor

Designed for use with Carrier Thermostats listed in this publication. This device enables the thermostat to display the outdoor temperature. This device also

is required to enable special thermostat features such as auxiliary heat lock out.

Usage Guideline:

Suggested for all Carrier thermostats listed in this publication.

## Accessory Description and Usage (Listed Alphabetically) (Continued)

### 9. Sound Hood

Wraparound sound reducing cover for the compressor. Reduces the sound level of the compressor.

Usage Guideline:

Suggested when unit is installed closer than 15 ft (4.57 m) to quiet areas, bedrooms, etc.

Suggested when unit is installed between two houses less than 10 ft (3.05 m) apart.

### 10. Support Feet

Four or five stick-on plastic feet that raise the unit 4 in. (101.6 mm) above the mounting pad. This allows sand, dirt, and other debris to be flushed from the unit base, minimizing corrosion.

Usage Guideline:

Suggested in the following applications:

Coastal installations.

Windy areas or where debris is normally circulating.

Rooftop installations.

For improved sound ratings.

### 11. Thermostatic Expansion Valve (TXV)

A modulating flow-control valve which meters refrigerant liquid flow rate into the evaporator in response to the superheat of the refrigerant gas leaving the evaporator.

Kit includes valve, adapter tubes, and external equalizer tube. Hard shut off types are available.

**NOTE:** When using a hard shut off TXV with single phase reciprocating compressors, a Compressor Start Assist Capacitor and Relay is required.

Usage Guideline:

Required to achieve AHRI ratings in certain equipment combinations. Refer to combination ratings.

Hard shut off TXV or LLS required in air conditioner long line applications.

Required for use on all zoning systems.

### 12. Time-Delay Relay

An SPST delay relay which briefly continues operation of indoor blower motor to provide additional cooling after the compressor cycles off.

**NOTE:** Most indoor unit controls include this feature. For those that do not, use the guideline below.

Usage Guideline:

For improved efficiency ratings for certain combinations of indoor and outdoor units. Refer to AHRI Unitary Directory.

### 13. Winter Start Control

This control is designed to alleviate nuisance opening of the low-pressure switch by bypassing it for the first 3 minutes of operation.

# TESTED AHRI COMBINATION RATINGS

For AHRI ratings certificates, please refer to the AHRI directory [www.ahridirectory.org](http://www.ahridirectory.org)

## A-WEIGHTED SOUND POWER (dBA)

UNIT SIZE – SERIES	Standard Rating (dBA)	TYPICAL OCTAVE BAND SPECTRUM (dBA without tone adjustment)						
		125	250	500	1000	2000	4000	8000
018–G	71	64.0	62.0	63.0	68.0	64.0	62.0	57.0
024–H	74	50.9	60.6	66.4	71.0	65.5	61.1	59.2
030–D	72	54.8	59.3	65.1	68.2	66.4	61.6	57.3
036–E	75	57.0	61.5	68.5	70.0	67.0	62.5	54.0
036–B (3–phase)								
036–F	75	50.5	61.0	64.5	67.0	62.5	60.0	52.5
042–B	78	56.0	64.5	69.5	71.0	66.0	64.0	59.0
048–G	76	55.5	62.9	69.6	71.2	69.5	66.3	59.1
048–D (3–phase)	76	54.0	63.0	69.5	71.5	70.0	66.0	58.5
060–E	79	57.5	67.0	72.0	75.0	72.5	68.0	61.0
060–B (3–phase)								

NOTE: Tested in accordance with AHRI Standard 270–2008 (not listed in AHRI).

## A-WEIGHTED SOUND POWER (dBA) WITH SOUND SHIELD

UNIT SIZE – SERIES	Standard Rating (dBA)	TYPICAL OCTAVE BAND SPECTRUM (dBA without tone adjustment)						
		125	250	500	1000	2000	4000	8000
018–G	70	66.0	64.0	64.0	67.0	63.0	60.0	54.0
024–H	74	51.1	61.3	66.6	71.2	65.0	60.0	55.6
030–D	72	51.9	59.3	64.8	67.3	65.2	61.1	54.8
036–E	74	57.0	61.5	67.5	70.0	66.5	62.5	56.0
036–B (3–phase)								
036–F	75	51.0	62.0	64.5	65.5	62.0	59.5	51.5
042–B	77	55.5	64.0	69.0	69.5	65.5	63.5	57.5
048–G	76	55.0	63.0	69.5	71.0	68.5	65.0	58.0
048–D (3–phase)	75	55.8	62.6	69.7	70.6	68.7	65.4	58.6
060–E	79	57.5	68.0	72.5	74.5	72.5	68.0	60.5
060–B (3–phase)								

NOTE: Tested in accordance with AHRI Standard 270–2008 (not listed in AHRI).

## METERING DEVICE

UNIT SIZE – SERIES	INDOOR	REQUIRED SUBCOOLING °F (°C)
018–G	TXV*	14 (7.8)
024–H		10 (5.6)
030–D		10 (5.6)
036–E		12 (6.7)
036–F	TXV*	11 (6.1)
036–B (3–phase)	TXV*	10 (5.6)
042–B	TXV*	12 (6.7)
048–G		13 (7.2)
048–D (3–phase)		10 (5.6)
060–E		15 (8.3)
060–B (3–phase)		10 (5.6)

\* TXV must be ordered separately when indoor coil is not equipped with a TXV. TXV must be hard–shutoff type.

## PISTON SIZE

### Outdoor unit connected to a factory approved indoor unit

Check piston size shipped with indoor unit to see if it matches required indoor piston size. If it does not match, replace indoor piston with correct piston size in table below:

UNIT SIZE – SERIES	FAN COIL	PISTON SIZE BY OUTDOOR MODEL
18–G	FB4CNF*	49
24–H	FB4CNF*	55
30–D	FB4CNF*	61
36–E	FB4CNF*	–
36–F	FB4CNF*	–
36–B (3–phase)	FB4CNF*	–
42–B	FB4CNF*	73
48–G	FB4CNF*	78
48–D (3–phase)	FB4CNF*	76

\* Ratings contained in this document are subject to change at any time. Always refer to the AHRI directory ([www.ahridirectory.org](http://www.ahridirectory.org)) for the most up–to–date ratings information.

NOTE: Pistons shipped with outdoor units are only qualified and approved with the above listed fan coils. The piston included with the FFMANP\* and FPMAN\* fan coils are unique to those products and CANNOT be replaced with the piston shipped with outdoor unit. Refer to the AHRI directory ([www.ahridirectory.org](http://www.ahridirectory.org)) to check if your combination can use a piston or requires an accessory TXV.



# DIMENSIONS

UNIT	SERIES	ELECTRICAL CHARACTERISTICS					A		B		C		D		E		F		G		H		I		J		K		OPERATING WEIGHT		SHIPPING WEIGHT		SHIPPING LENGTH / WIDTH (Sq.)		SHIPPING HEIGHT	
							INCH	MM	INCH	MM	INCH	MM	INCH	MM	INCH	MM	INCH	MM	INCH	MM	INCH	MM	INCH	MM	INCH	MM	INCH	MM	INCH	MM	INCH	MM	Lbs	Kgs	Lbs	Kgs
PA13NA018	G	Y	N	N	N	23 1/8	587.3	24 7/8	631.6	3/4	19.1	4 7/16	113.0	18 1/16	459.0	7 13/16	197.9	5/16	7.9	3	76.2	12	304.8	11 3/4	298.5	11 7/8	301.6	104	47.2	120	54.4	24 1/8	612.7	26 7/16	672.1	
PA13NA024	H	Y	N	N	N	23 1/8	587.3	24 7/8	631.6	3/4	19.1	4 7/16	113.0	18 1/16	459.0	7 13/16	197.9	5/16	7.9	3	76.2	12 1/2	317.5	11	279.4	12	304.8	107	48.5	127	57.6	24 1/8	612.7	26 7/16	672.1	
PA13NA030	D	Y	N	N	N	25 3/4	654.0	28 11/16	728.7	3/4	19.1	4 7/16	113.0	21 1/4	539.9	9 1/8	231.3	5/16	7.9	3	76.2	14 1/2	368.3	15 1/2	393.7	12 1/2	317.5	126	57.2	149	67.6	26 3/4	679.9	30 3/8	771.2	
PA13NA036	E	Y	N	N	N	23 1/8	587.3	35 1/16	890.7	7/8	22.2	4 7/16	113.0	18 1/16	459.0	7 13/16	197.9	5/16	7.9	3	76.2	12	304.8	11 3/4	298.5	13 3/4	349.3	128	58.1	142	64.4	24 1/8	612.7	36 11/16	931.3	
PA13PA036	B	N	Y	N	N	23 1/8	587.3	35 1/16	890.7	7/8	22.2	4 7/16	113.0	18 1/16	459.0	7 13/16	197.9	5/16	7.9	3	76.2	12	304.8	11 3/4	298.5	13 3/4	349.3	128	58.1	142	64.4	24 1/8	612.7	36 11/16	931.3	
PA13NA036	F	Y	N	N	N	31 3/16	792.5	24 7/8	631.6	7/8	22.2	6 9/16	166.1	24 11/16	626.3	9 1/8	231.3	5/16	7.9	3	76.2	15 9/16	395.3	16 1/2	419.1	10 1/4	260.4	134	60.8	151	68.5	32 3/16	817.9	26 7/16	672.1	
PA13NA042	B	Y	N	N	N	31 3/16	792.5	31 11/16	804.3	7/8	22.2	6 9/16	166.1	24 11/16	626.3	9 1/8	231.3	5/16	7.9	3	76.2	16	406.4	15 1/2	393.7	13 3/4	349.3	164	74.4	178	80.7	32 3/16	817.9	33 1/4	844.9	
PA13NA048	G	Y	N	N	N	31 3/16	792.5	35 1/16	890.7	7/8	22.2	6 9/16	166.1	24 11/16	626.3	9 1/8	231.3	5/16	7.9	3	76.2	15 3/4	400.1	16 3/8	415.9	15 5/8	396.9	175	79.4	205	93.0	32 3/16	817.9	36 11/16	931.3	
PA13PA048	D	N	Y	N	N	31 3/16	792.5	35 1/16	890.7	7/8	22.2	6 9/16	166.1	24 11/16	626.3	9 1/8	231.3	5/16	7.9	3	76.2	16	406.4	15 1/2	393.7	15 1/2	393.7	174	78.9	187	84.8	32 3/16	817.9	36 11/16	931.3	
PA13NA060	E	Y	N	N	N	31 3/16	792.5	28 1/4	718.0	7/8	22.2	6 9/16	166.1	24 11/16	626.3	9 1/8	231.3	5/16	7.9	3	76.2	16	406.4	15 1/2	393.7	12 3/4	323.9	195	88.5	210	95.3	32 3/16	817.9	29 7/8	758.5	
PA13PA060	B	N	Y	N	N	31 3/16	792.5	28 1/4	718.0	7/8	22.2	6 9/16	166.1	24 11/16	626.3	9 1/8	231.3	5/16	7.9	3	76.2	16	406.4	15 1/2	393.7	12 3/4	323.9	195	88.5	210	95.3	32 3/16	817.9	29 7/8	758.5	

206-230-1-60	Y=YES N=NO
209/230-3-60	
460-3-60	
575-3-60	

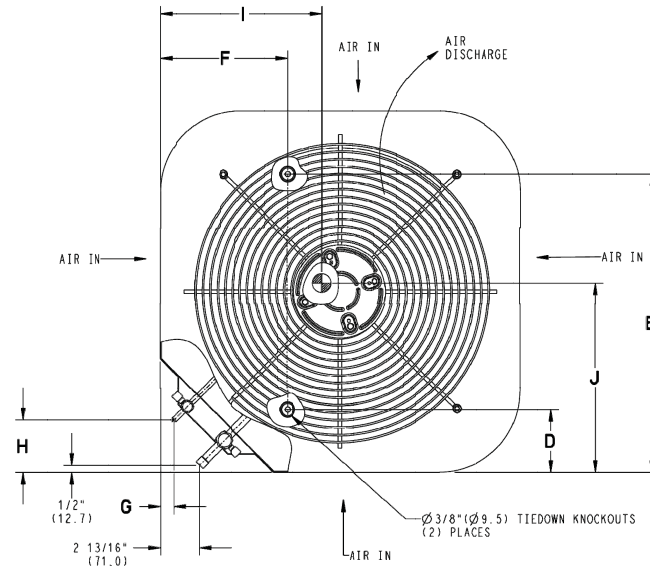
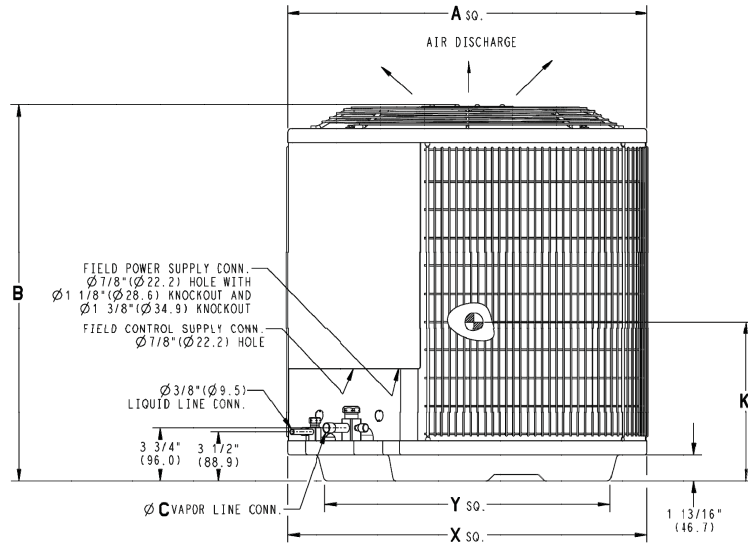

UNIT SIZE	"X" MINIMUM GROUND MOUNTING PAD APPLICATION DIMENSIONS		"Y" MINIMUM ROOF-TOP MOUNTING PAD APPLICATION DIMENSIONS	
18,24,36(E,B)	23 1/8	587.3	17 7/8	454.6
30	25 3/4	654.0	20 7/16	518.5
36(F),42,48,60	31 3/16	792.5	22 15/16	583.2
-	-	-	-	-

NOTE: ALL DIMENSIONS IN INCH (MM)

U.S. EXPORT CLASSIFICATION: EAR99

# CLEARANCES

Clearances (various examples)

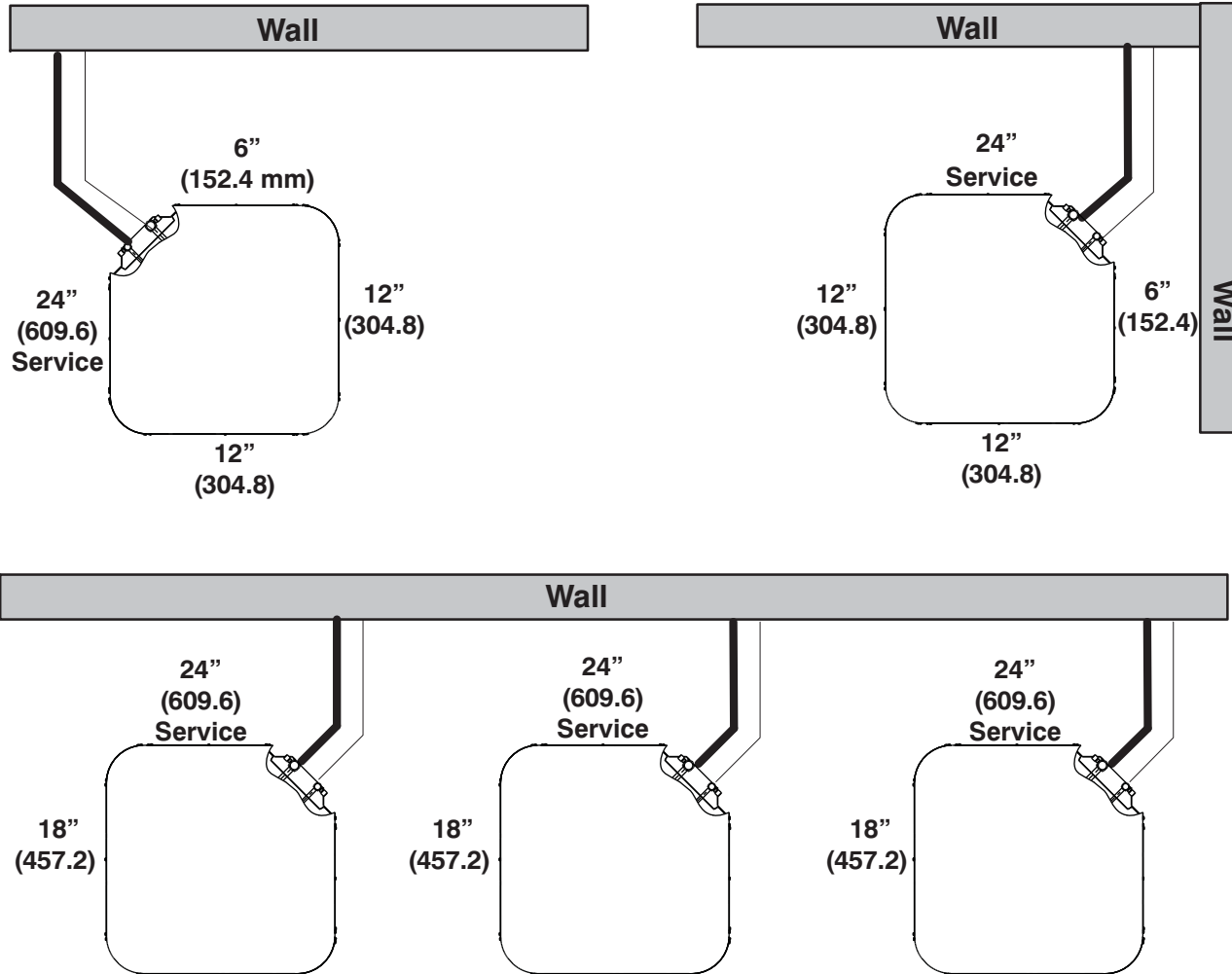

Note: Numbers in ( ) = mm

**IMPORTANT:** When installing multiple units in an alcove, roof well, or partially enclosed area, ensure there is adequate ventilation to prevent re-circulation of discharge air.

# DETAILED COOLING CAPACITIES#

EVAPORATOR AIR		CONDENSER ENTERING AIR TEMPERATURES °F (°C)														
CFM	EWB °F (°C)	75 (23.9)			85 (29.4)			95 (35)			105 (40.6)			115 (46.1)		
		Capacity MBtuh		Total System KW**	Capacity MBtuh		Total System KW**	Capacity MBtuh		Total System KW**	Capacity MBtuh		Total System KW**	Capacity MBtuh		Total System KW**
		Total	Sens‡		Total	Sens‡		Total	Sens‡		Total	Sens‡		Total	Sens‡	
<b>PA13NA018 – G Outdoor Section With CNPV*2414AL* Indoor Section</b>																
525	72 (22.2)	21.21	11.38	1.27	20.31	11.05	1.42	19.41	10.71	1.59	18.37	10.33	1.78	17.33	9.96	2.02
	67 (19.4)	19.33	14.06	1.28	18.52	13.73	1.43	17.62	13.36	1.60	16.64	12.96	1.79	15.65	12.56	2.02
	63 (17.2)	18.04	16.20	1.29	17.23	15.83	1.44	16.39	15.44	1.60	15.49	15.02	1.79	14.60	14.56	2.02
	62 (16.7)	17.76	16.72	1.29	16.97	16.34	1.44	16.16	15.93	1.60	15.36	15.36	1.79	14.58	14.58	2.02
	57 (13.9)	17.47	17.47	1.30	16.77	16.77	1.44	16.08	16.08	1.60	15.34	15.34	1.79	14.56	14.56	2.02
600	72 (22.2)	21.47	11.95	1.30	20.62	11.65	1.45	19.68	11.30	1.62	18.64	10.93	1.81	17.55	10.55	2.05
	67 (19.4)	19.71	15.05	1.31	18.81	14.68	1.46	17.90	14.32	1.63	16.89	13.92	1.82	15.88	13.52	2.05
	63 (17.2)	18.40	17.43	1.32	17.61	17.05	1.46	16.77	16.64	1.63	15.96	15.96	1.82	15.14	15.14	2.05
	62 (16.7)	18.19	18.01	1.32	17.54	17.28	1.46	16.74	16.74	1.63	15.96	15.96	1.82	15.14	15.14	2.05
	57 (13.9)	18.12	18.12	1.32	17.44	17.44	1.47	16.72	16.72	1.63	15.93	15.93	1.82	15.12	15.12	2.05
675	72 (22.2)	21.70	12.53	1.33	20.81	12.21	1.48	19.86	11.87	1.65	18.78	11.49	1.84	17.62	11.09	2.06
	67 (19.4)	19.88	15.95	1.34	19.03	15.61	1.49	18.11	15.24	1.66	17.08	14.83	1.85	16.07	14.43	2.08
	63 (17.2)	18.79	18.56	1.35	18.02	18.02	1.49	17.27	17.27	1.66	16.44	16.44	1.85	15.60	15.60	2.08
	62 (16.7)	18.71	18.71	1.34	18.02	18.02	1.49	17.26	17.26	1.66	16.44	16.44	1.85	15.59	15.59	2.08
	57 (13.9)	18.70	18.70	1.34	18.00	18.00	1.49	17.24	17.24	1.66	16.41	16.41	1.85	15.57	15.57	2.08

EVAPORATOR AIR		CONDENSER ENTERING AIR TEMPERATURES °F (°C)														
CFM	EWB °F (°C)	75 (23.9)			85 (29.4)			95 (35)			105 (40.6)			115 (46.1)		
		Capacity Mbtuh		Total System KW**	Capacity MBtuh		Total System KW**	Capacity MBtuh		Total System KW**	Capacity MBtuh		Total System KW**	Capacity MBtuh		Total System KW**
		Total	Sens‡		Total	Sens‡		Total	Sens‡		Total	Sens‡		Total	Sens‡	
<b>PA13NA024 – H Outdoor Section With CNPV*2414AL* Indoor Section</b>																
700	72 (22.2)	27.00	13.49	1.54	26.00	13.12	1.78	24.88	12.71	2.05	23.60	12.25	2.37	22.20	11.77	2.74
	67 (19.4)	24.70	16.72	1.54	23.76	16.33	1.78	22.68	15.90	2.05	21.51	15.44	2.37	20.23	14.95	2.74
	63 (17.2)††	23.00	16.10	1.55	22.07	15.69	1.78	21.07	15.26	2.06	19.97	14.80	2.37	18.77	14.30	2.75
	62 (16.7)	22.70	19.89	1.55	21.81	19.46	1.78	20.88	18.99	2.06	19.95	19.95	2.37	18.98	18.98	2.75
	57 (13.9)	22.29	22.29	1.55	21.58	21.58	1.78	20.79	20.79	2.06	19.92	19.92	2.37	18.96	18.96	2.75
800	72 (22.2)	27.39	14.17	1.57	26.35	13.79	1.81	25.20	13.38	2.09	23.87	12.92	2.41	22.42	12.43	2.78
	67 (19.4)	25.08	17.82	1.58	24.11	17.43	1.82	23.00	17.00	2.09	21.79	16.53	2.41	20.47	16.03	2.78
	63 (17.2)††	23.39	17.14	1.58	22.43	16.72	1.82	21.39	16.28	2.09	20.26	15.81	2.41	19.02	15.30	2.79
	62 (16.7)	23.24	21.32	1.58	22.43	22.43	1.82	21.59	21.59	2.09	20.66	20.66	2.41	19.62	19.62	2.79
	57 (13.9)	23.16	23.16	1.58	22.40	22.40	1.82	21.56	21.56	2.09	20.63	20.63	2.41	19.60	19.60	2.79
900	72 (22.2)	27.66	14.81	1.61	26.59	14.43	1.85	25.41	14.02	2.13	24.05	13.56	2.45	22.57	13.06	2.82
	67 (19.4)	25.36	18.88	1.61	24.37	18.49	1.85	23.24	18.05	2.13	22.00	17.57	2.45	20.65	17.05	2.82
	63 (17.2)††	23.67	18.11	1.62	22.70	17.70	1.85	21.63	17.25	2.13	20.47	16.77	2.45	19.21	16.24	2.83
	62 (16.7)	23.89	23.89	1.62	23.10	23.10	1.85	22.21	22.21	2.13	21.22	21.22	2.45	20.13	20.13	2.83
	57 (13.9)	23.86	23.86	1.62	23.07	23.07	1.85	22.18	22.18	2.13	21.20	21.20	2.45	20.11	20.11	2.83

See notes on page 14

# DETAILED COOLING CAPACITIES# (CONT.)

EVAPORATOR AIR		CONDENSER ENTERING AIR TEMPERATURES ° F (° C)														
CFM	EWB ° F (° C)	75 (23.9)			85 (29.4)			95 (35)			105 (40.6)			115 (46.1)		
		Capacity MBtu/h†		Total Sys- tem KW**	Capacity MBtu/h†		Total Sys- tem KW**	Capacity MBtu/h†		Total Sys- tem KW**	Capacity MBtu/h†		Total Sys- tem KW**	Capacity MBtu/h†		Total Sys- tem KW**
		Total	Sens‡		Total	Sens‡		Total	Sens‡		Total	Sens‡		Total	Sens‡	
<b>PA13NA030 – D Outdoor Section With CNPV*3117AL* Indoor Section</b>																
875	72 (22.2)	33.22	16.91	2.06	31.69	16.39	2.26	30.06	15.84	2.50	28.48	15.31	2.77	27.41	14.95	3.12
	67 (19.4)	30.28	21.08	2.05	28.91	20.56	2.25	27.54	20.04	2.49	26.13	19.52	2.76	24.98	19.08	3.10
	63 (17.2)††	28.16	20.25	2.04	27.05	19.80	2.25	25.78	19.28	2.49	24.46	18.76	2.76	22.86	18.13	3.08
	62 (16.7)	28.07	25.27	2.05	26.80	26.56	2.25	25.71	25.71	2.48	24.60	24.60	2.76	23.29	23.29	3.08
	57 (13.9)	27.67	27.67	2.04	26.71	26.71	2.25	25.67	25.67	2.48	24.55	24.55	2.76	23.26	23.26	3.08
970	72 (22.2)	33.81	17.69	2.10	32.00	17.08	2.30	30.30	16.51	2.53	28.71	15.99	2.81	27.49	15.59	3.14
	67 (19.4)	30.64	22.21	2.09	29.20	21.67	2.29	27.80	21.15	2.53	26.35	20.61	2.80	25.09	20.14	3.13
	63 (17.2)††	28.55	21.32	2.08	27.34	20.83	2.29	26.03	20.31	2.52	24.67	19.76	2.79	23.13	19.14	3.11
	62 (16.7)	28.67	28.67	2.09	27.47	27.47	2.29	26.36	26.36	2.52	25.20	25.20	2.80	24.14	24.14	3.14
	57 (13.9)	28.57	28.57	2.09	27.43	27.43	2.29	26.33	26.33	2.52	25.14	25.14	2.79	24.21	24.21	3.13
1125	72 (22.2)	34.10	18.74	2.16	32.36	18.17	2.36	30.60	17.59	2.60	28.93	17.05	2.87	27.70	16.66	3.20
	67 (19.4)	31.10	23.99	2.15	29.57	23.42	2.36	28.11	22.88	2.59	26.63	22.32	2.86	25.46	21.89	3.21
	63 (17.2)††	29.25	23.06	2.15	27.68	22.44	2.35	26.34	21.90	2.59	24.91	21.33	2.86	23.65	20.80	3.19
	62 (16.7)	29.57	29.57	2.15	28.41	28.41	2.35	27.20	27.20	2.59	25.99	25.99	2.86	25.03	25.03	3.20
	57 (13.9)	29.57	29.57	2.15	28.38	28.38	2.35	27.20	27.20	2.59	25.95	25.95	2.86	24.99	24.99	3.20

EVAPORATOR AIR		CONDENSER ENTERING AIR TEMPERATURES ° F (° C)														
CFM	EWB ° F (° C)	75 (23.9)			85 (29.4)			95 (35)			105 (40.6)			115 (46.1)		
		Capacity MBtu/h†		Total Sys- tem KW**	Capacity MBtu/h†		Total Sys- tem KW**	Capacity MBtu/h†		Total Sys- tem KW**	Capacity MBtu/h†		Total Sys- tem KW**	Capacity MBtu/h†		Total Sys- tem KW**
		Total	Sens‡		Total	Sens‡		Total	Sens‡		Total	Sens‡		Total	Sens‡	
<b>PA13NA036 – F Outdoor Section With CAP**3721AL** Indoor Section</b>																
1050	72 (22.2)	41.02	21.66	2.54	39.40	21.07	2.83	37.67	20.45	3.14	35.71	19.75	3.48	33.44	18.95	3.91
	67 (19.4)	37.34	26.81	2.53	35.82	26.20	2.81	34.20	25.55	3.11	32.39	24.83	3.45	30.24	23.98	3.87
	63 (17.2)††	34.68	25.78	2.53	33.23	25.15	2.81	31.71	24.49	3.10	29.97	23.75	3.44	27.94	22.89	3.85
	62 (16.7)	34.09	31.81	2.53	32.69	31.14	2.81	31.25	31.03	3.10	29.79	29.79	3.44	28.17	28.17	3.85
	57 (13.9)	33.44	33.44	2.53	32.31	32.31	2.81	31.10	31.10	3.10	29.74	29.74	3.43	28.12	28.12	3.85
1200	72 (22.2)	41.67	22.87	2.60	40.00	22.28	2.90	38.19	21.64	3.21	36.16	20.93	3.56	33.84	20.12	3.98
	67 (19.4)	37.97	28.72	2.59	36.42	28.10	2.88	34.74	27.44	3.18	32.86	26.71	3.52	30.66	25.85	3.93
	63 (17.2)††	35.32	27.56	2.59	33.82	26.92	2.87	32.24	26.25	3.17	30.45	25.49	3.50	28.36	24.62	3.92
	62 (16.7)	35.04	34.70	2.59	33.72	33.72	2.87	32.44	32.44	3.16	30.99	30.99	3.50	29.26	29.26	3.92
	57 (13.9)	34.87	34.87	2.59	33.67	33.67	2.87	32.39	32.39	3.16	30.95	30.95	3.50	29.22	29.22	3.92
1350	72 (22.2)	42.14	24.02	2.67	40.41	23.42	2.97	38.56	22.78	3.28	36.48	22.06	3.63	34.10	21.25	4.05
	67 (19.4)	38.45	30.58	2.65	36.85	29.95	2.94	35.14	29.28	3.24	33.22	28.53	3.58	30.99	27.65	4.00
	63 (17.2)††	35.80	29.28	2.65	34.26	28.63	2.93	32.63	27.95	3.23	30.83	27.19	3.57	28.68	26.27	3.98
	62 (16.7)	36.12	36.12	2.65	34.86	34.86	2.93	33.50	33.50	3.23	31.98	31.98	3.57	30.16	30.16	3.99
	57 (13.9)	36.07	36.07	2.65	34.81	34.81	2.93	33.45	33.45	3.23	31.94	31.94	3.57	30.12	30.12	3.99

# DETAILED COOLING CAPACITIES# (CONT.)

EVAPORATOR AIR		CONDENSER ENTERING AIR TEMPERATURES ° F (° C)														
CFM	EWB ° F (° C)	75 (23.9)			85 (29.4)			95 (35)			105 (40.6)			115 (46.1)		
		Capacity MBtu/h†		Total System KW**	Capacity MBtu/h†		Total System KW**	Capacity MBtu/h†		Total System KW**	Capacity MBtu/h†		Total System KW**	Capacity MBtu/h†		Total System KW**
		Total	Sens‡		Total	Sens‡		Total	Sens‡		Total	Sens‡		Total	Sens‡	
<b>PA13NA042—B Outdoor Section With CAP**4221AL** Indoor Section</b>																
1275	72 (22.2)	48.80	25.83	3.03	46.63	25.00	3.35	44.37	24.15	3.73	41.99	23.27	4.17	39.49	22.35	4.68
	67 (19.4)	44.50	31.73	2.97	42.51	30.90	3.28	40.44	30.04	3.64	38.27	29.15	4.07	35.97	28.21	4.58
	63 (17.2)††	41.32	30.53	2.92	39.48	29.70	3.23	37.55	28.84	3.59	35.52	27.95	4.01	33.37	27.01	4.51
	62 (16.7)	40.82	37.56	2.92	39.08	36.71	3.23	37.26	35.78	3.59	35.38	34.77	4.01	33.52	33.52	4.51
	57 (13.9)	39.84	39.84	2.91	38.41	38.41	3.22	36.87	36.87	3.58	35.24	35.24	4.01	33.48	33.48	4.51
1400	72 (22.2)	49.54	27.00	3.12	47.29	26.16	3.44	44.94	25.29	3.82	42.48	24.40	4.26	39.89	23.46	4.77
	67 (19.4)	45.19	33.62	3.05	43.14	32.78	3.36	41.00	31.91	3.73	38.77	31.01	4.16	36.40	30.06	4.66
	63 (17.2)††	42.00	32.30	3.00	40.11	31.46	3.31	38.11	30.59	3.67	36.04	29.69	4.09	33.79	28.71	4.59
	62 (16.7)	41.74	40.09	3.00	40.01	39.15	3.31	38.18	38.18	3.67	36.47	36.47	4.10	34.60	34.60	4.61
	57 (13.9)	41.35	41.35	2.99	39.81	39.81	3.31	38.17	38.17	3.67	36.43	36.43	4.10	34.57	34.57	4.61
1575	72 (22.2)	50.11	28.13	3.20	47.78	27.28	3.52	45.37	26.40	3.90	42.83	25.49	4.34	40.18	24.54	4.86
	67 (19.4)	45.76	35.48	3.12	43.64	34.62	3.44	41.45	33.74	3.81	39.16	32.81	4.24	36.73	31.83	4.75
	63 (17.2)††	42.56	34.03	3.08	40.60	33.17	3.39	38.55	32.28	3.75	36.40	31.34	4.17	34.14	30.34	4.67
	62 (16.7)	42.60	42.59	3.08	41.00	41.00	3.40	39.27	39.27	3.76	37.44	37.44	4.20	35.48	35.48	4.71
	57 (13.9)	42.59	42.59	3.08	40.96	40.96	3.39	39.22	39.22	3.76	37.40	37.40	4.20	35.44	35.44	4.71

EVAPORATOR AIR		CONDENSER ENTERING AIR TEMPERATURES ° F (° C)														
CFM	EWB ° F (° C)	75 (23.9)			85 (29.4)			95 (35)			105 (40.6)			115 (46.1)		
		Capacity MBtu/h†		Total System KW**	Capacity MBtu/h†		Total System KW**	Capacity MBtu/h†		Total System KW**	Capacity MBtu/h†		Total System KW**	Capacity MBtu/h†		Total System KW**
		Total	Sens‡		Total	Sens‡		Total	Sens‡		Total	Sens‡		Total	Sens‡	
<b>PA13NA048—G Outdoor Section With CAP**6021AL** Indoor Section</b>																
1275	72 (22.2)	53.20	26.31	3.12	50.85	25.14	3.54	48.37	23.95	4.02	45.80	22.76	4.56	43.04	21.54	5.16
	67 (19.4)	48.41	32.16	3.11	46.26	30.89	3.51	43.98	29.61	3.99	41.58	28.31	4.54	39.04	26.99	5.14
	63 (17.2)††	44.98	30.98	3.09	42.95	29.73	3.50	40.81	28.45	3.98	38.56	27.16	4.52	36.17	25.84	5.12
	62 (16.7)	44.28	37.94	3.09	42.32	36.55	3.49	40.26	35.14	3.97	38.12	33.68	4.52	35.88	35.88	5.12
	57 (13.9)	42.89	42.89	3.08	41.29	41.29	3.49	39.60	39.60	3.97	37.79	37.79	4.51	35.87	35.87	5.12
1425	72 (22.2)	54.02	27.40	3.18	51.59	26.20	3.60	49.04	25.00	4.08	46.35	23.77	4.62	43.54	22.54	5.22
	67 (19.4)	49.19	33.90	3.17	46.95	32.60	3.58	44.60	31.28	4.06	42.14	29.94	4.60	39.52	28.58	5.20
	63 (17.2)††	45.73	32.61	3.15	43.63	31.31	3.56	41.42	30.00	4.04	39.10	28.67	4.58	36.64	27.31	5.19
	62 (16.7)	45.16	40.27	3.15	43.16	38.80	3.56	41.10	37.27	4.04	39.09	39.09	4.58	37.07	37.07	5.19
	57 (13.9)	44.41	44.41	3.15	42.73	42.73	3.55	40.93	40.93	4.04	39.04	39.04	4.58	37.01	37.01	5.19
1575	72 (22.2)	54.66	28.45	3.24	52.17	27.23	3.65	49.54	25.99	4.14	46.79	24.75	4.68	43.91	23.49	5.29
	67 (19.4)	49.79	35.58	3.23	47.50	34.25	3.64	45.10	32.89	4.12	42.56	31.51	4.66	39.90	30.11	5.27
	63 (17.2)††	46.31	34.17	3.21	44.17	32.84	3.62	41.90	31.49	4.10	39.52	30.12	4.64	37.02	28.73	5.25
	62 (16.7)	45.98	42.43	3.21	44.01	43.95	3.62	42.13	42.13	4.10	40.15	40.15	4.65	38.03	38.03	5.25
	57 (13.9)	45.72	45.72	3.21	43.95	43.95	3.62	42.08	42.08	4.10	40.10	40.10	4.65	37.98	37.98	5.25

See notes on page 14

## DETAILED COOLING CAPACITIES# (CONT.)

EVAPORATOR AIR		CONDENSER ENTERING AIR TEMPERATURES ° F (° C)														
		75 (23.9)			85 (29.4)			95 (35)			105 (40.6)			115 (46.1)		
CFM	EWB ° F (° C)	Capacity MBtu/h†		Total Sys- tem KW**	Capacity MBtu/h†		Total Sys- tem KW**	Capacity MBtu/h†		Total Sys- tem KW**	Capacity MBtu/h†		Total Sys- tem KW**	Capacity MBtu/h†		Total Sys- tem KW**
		Total	Sens‡		Total	Sens‡		Total	Sens‡		Total	Sens‡		Total	Sens‡	
<b>PA13NA060—E Outdoor Section With CAP**6024A** Indoor Section</b>																
1750	72 (22.2)	68.71	34.82	4.37	65.76	33.74	4.81	62.59	32.60	5.30	59.21	31.39	5.84	55.54	30.09	6.42
	67 (19.4)	63.16	43.00	4.29	60.43	41.90	4.74	57.50	40.73	5.23	54.39	39.50	5.77	51.03	38.20	6.36
	63 (17.2)††	59.15	41.80	4.24	56.59	40.69	4.68	53.84	39.50	5.18	50.92	38.26	5.72	47.79	36.96	6.31
	62 (16.7)	58.14	51.13	4.23	55.65	49.99	4.67	53.01	48.77	5.16	50.27	47.45	5.71	47.55	47.55	6.31
	57 (13.9)	56.63	56.63	4.21	54.60	54.60	4.66	52.42	52.42	5.16	50.09	50.09	5.71	47.55	47.55	6.31
2000	72 (22.2)	69.71	36.45	4.48	66.67	35.37	4.92	63.38	34.20	5.41	59.88	32.98	5.95	56.07	31.67	6.53
	67 (19.4)	64.15	45.67	4.40	61.31	44.55	4.85	58.27	43.36	5.34	55.05	42.13	5.87	51.58	40.80	6.46
	63 (17.2)††	60.14	44.30	4.35	57.47	43.18	4.79	54.61	41.98	5.28	51.60	40.73	5.82	48.36	39.39	6.42
	62 (16.7)	59.33	54.75	4.34	56.80	53.54	4.78	54.23	54.23	5.28	51.77	51.77	5.83	49.05	49.05	6.42
	57 (13.9)	58.75	58.75	4.33	56.59	56.59	4.78	54.26	54.26	5.28	51.77	51.77	5.83	49.05	49.05	6.42
2250	72 (22.2)	70.44	37.99	4.59	67.31	36.90	5.03	63.93	35.73	5.52	60.33	34.49	6.05	56.41	33.16	6.63
	67 (19.4)	64.85	48.20	4.51	61.94	47.09	4.95	58.82	45.89	5.44	55.52	44.63	5.98	51.96	43.27	6.56
	63 (17.2)††	60.84	46.68	4.45	58.11	45.56	4.90	55.17	44.34	5.39	52.08	43.07	5.93	48.77	41.69	6.52
	62 (16.7)	60.44	60.44	4.45	58.18	58.18	4.90	55.72	55.72	5.40	53.10	53.10	5.94	50.23	50.23	6.54
	57 (13.9)	60.47	60.47	4.45	58.19	58.19	4.90	55.73	55.73	5.40	53.10	53.10	5.94	50.23	50.23	6.54

**NOTES:**

† Total and sensible capacities are net capacities. Blower motor heat has been subtracted.

‡ Sensible capacities shown are based on 80°F (27°C) entering air at the indoor coil. For sensible capacities at other than 80°F (27°C), deduct 835 Btuh (245 kW) per 1000 CFM (480 L/S) of indoor coil air for each degree below 80°F (27°C), or add 835 Btuh (245 kW) per 1000 CFM (480 L/S) of indoor coil air per degree above 80°F (27°C).

# Detailed cooling capacities are based on indoor and outdoor unit at the same elevation per AHRI standard 210/240–2008. If additional tubing length and/or indoor unit is located above outdoor unit, a slight variation in capacity may occur.

\*\* System kw is total of indoor and outdoor unit kilowatts.

EWB — Entering Wet Bulb

**NOTE:** When the required data fall between the published data, interpolation may be performed. Extrapolation is not an acceptable practice.

SST ° F (° C)		CONDENSER ENTERING AIR TEMPERATURES ° F (° C)						
		55 (12.78)	65 (18.33)	75 (23.89)	85 (29.44)	95 (35.0)	105 (40.56)	115 (46.11)
<b>PA13NA018-G</b>								
30 (-1.11)	TCG	16.90	15.70	14.60	13.60	12.60	10.50	9.30
	SDT	71.20	79.70	88.40	97.90	107.30	126.60	137.10
	KW	0.88	0.99	1.10	1.24	1.39	1.78	2.04
35 (1.67)	TCG	18.60	17.40	16.20	15.10	14.00	11.80	10.50
	SDT	71.50	80.80	89.50	98.90	108.20	127.40	138.00
	KW	0.86	0.98	1.10	1.24	1.40	1.78	2.06
40 (4.44)	TCG	20.40	19.10	17.90	16.70	15.60	13.20	11.80
	SDT	73.50	81.90	90.60	99.90	109.20	128.70	137.60
	KW	0.87	0.98	1.10	1.24	1.40	1.80	2.03
45 (7.22)	TCG	22.20	20.90	19.60	18.40	17.20	14.60	13.20
	SDT	73.40	83.10	91.70	101.00	110.30	129.40	138.50
	KW	0.84	0.97	1.09	1.24	1.40	1.80	2.04
50 (10.0)	TCG	24.10	22.70	21.40	20.20	18.90	16.20	14.60
	SDT	74.30	83.50	92.80	102.10	111.40	130.40	139.50
	KW	0.83	0.95	1.09	1.24	1.40	1.81	2.04
55 (12.78)	TCG	26.10	24.70	23.40	22.00	20.60	17.80	16.10
	SDT	75.50	84.80	94.00	103.30	112.50	131.50	140.30
	KW	0.81	0.94	1.08	1.23	1.40	1.81	2.04
<b>PA13NA024-H</b>								
30 (-1.11)	TCG	18.60	18.00	17.40	16.60	15.80	14.90	13.80
	SDT	78.20	87.90	97.80	107.70	117.70	127.80	138.10
	KW	1.03	1.19	1.39	1.61	1.88	2.19	2.57
35 (1.67)	TCG	20.60	20.00	19.30	18.50	17.60	16.60	15.40
	SDT	79.80	89.50	99.30	109.10	119.10	129.20	139.30
	KW	1.04	1.20	1.39	1.62	1.89	2.21	2.59
40 (4.44)	TCG	22.70	22.10	21.30	20.50	19.50	18.40	17.20
	SDT	81.40	91.10	100.80	110.60	120.50	130.50	140.40
	KW	1.04	1.21	1.40	1.64	1.91	2.23	2.60
45 (7.22)	TCG	25.00	24.30	23.50	22.60	21.60	20.40	19.10
	SDT	83.10	92.80	102.40	112.10	121.90	131.80	141.60
	KW	1.04	1.21	1.41	1.65	1.92	2.24	2.62
50 (10.0)	TCG	27.50	26.70	25.80	24.90	23.80	22.50	21.10
	SDT	84.90	94.50	104.00	113.60	123.30	133.10	142.70
	KW	1.05	1.22	1.42	1.66	1.93	2.26	2.63
55 (12.78)	TCG	30.10	29.30	28.30	27.30	26.10	24.80	23.30
	SDT	86.70	96.20	105.70	115.20	124.80	134.40	143.90
	KW	1.05	1.22	1.43	1.66	1.94	2.27	2.64
<b>PA13NA030-D</b>								
30 (-1.11)	TCG	26.40	24.90	23.20	21.70	20.20	18.70	17.10
	SDT	71.50	80.00	88.80	98.10	107.40	116.70	126.00
	KW	1.43	1.58	1.75	1.95	2.18	2.44	2.74
35 (1.67)	TCG	28.80	27.50	25.50	23.90	22.20	20.60	19.20
	SDT	71.70	81.30	89.90	99.20	108.40	117.70	127.20
	KW	1.41	1.58	1.75	1.96	2.19	2.45	2.76
40 (4.44)	TCG	31.90	29.60	27.90	26.20	24.40	22.60	20.70
	SDT	73.40	82.00	91.20	100.30	109.50	118.70	127.90
	KW	1.42	1.57	1.76	1.96	2.20	2.46	2.77
45 (7.22)	TCG	34.60	32.60	30.50	28.60	26.60	24.60	23.30
	SDT	74.50	83.50	92.50	101.60	110.70	119.70	129.40
	KW	1.42	1.58	1.76	1.97	2.20	2.47	2.80
50 (10.0)	TCG	37.40	35.60	33.40	31.10	29.00	26.70	25.40
	SDT	75.80	85.00	94.00	102.90	111.90	120.90	130.50
	KW	1.41	1.59	1.77	1.97	2.21	2.48	2.81
55 (12.78)	TCG	40.80	38.60	36.10	33.80	31.50	29.10	28.00
	SDT	77.50	86.50	95.30	104.30	113.20	122.10	132.00
	KW	1.41	1.59	1.77	1.98	2.22	2.49	2.83

See notes on page 17

# CONDENSER ONLY RATINGS\* CONTINUED

SST ° F (° C)		CONDENSER ENTERING AIR TEMPERATURES ° F (° C)						
		55 (12.78)	65 (18.33)	75 (23.89)	85 (29.44)	95 (35.0)	105 (40.56)	115 (46.11)
<b>PA13NA036 – F</b>								
30 (-1.11)	TCG	30.70	28.50	26.70	25.10	23.50	21.90	20.00
	SDT	70.70	80.00	89.40	98.80	108.20	117.60	127.00
	KW	1.61	1.94	2.21	2.47	2.73	3.03	3.41
35 (1.67)	TCG	33.70	31.40	29.50	27.80	26.10	24.30	22.20
	SDT	71.80	81.10	90.40	99.80	109.20	118.50	127.80
	KW	1.58	1.91	2.19	2.45	2.72	3.03	3.41
40 (4.44)	TCG	36.90	34.60	32.50	30.70	28.80	26.80	24.60
	SDT	72.90	82.20	91.50	100.90	110.20	119.40	128.60
	KW	1.55	1.89	2.17	2.44	2.71	3.02	3.41
45 (7.22)	TCG	40.40	37.90	35.80	33.80	31.70	29.50	27.10
	SDT	74.20	83.40	92.70	102.00	111.20	120.40	129.50
	KW	1.53	1.87	2.16	2.43	2.71	3.03	3.41
50 (10.0)	TCG	44.20	41.60	39.30	37.10	34.80	32.40	29.80
	SDT	75.50	84.70	94.00	103.20	112.30	121.40	130.50
	KW	1.52	1.86	2.16	2.44	2.72	3.04	3.43
55 (12.78)	TCG	48.20	45.50	43.00	40.60	38.10	35.50	32.60
	SDT	77.00	86.10	95.30	104.40	113.50	122.50	131.50
	KW	1.52	1.87	2.17	2.45	2.74	3.07	3.46
<b>PA13NA042 – B</b>								
30 (-1.11)	TCG	38.00	36.00	33.90	31.90	29.70	27.60	25.30
	SDT	73.20	82.30	91.40	100.60	109.80	119.10	128.40
	KW	1.95	2.20	2.48	2.80	3.14	3.53	3.95
35 (1.67)	TCG	41.90	39.70	37.40	35.10	32.80	30.50	28.00
	SDT	74.80	83.70	92.80	101.90	111.00	120.20	129.40
	KW	1.97	2.22	2.50	2.81	3.16	3.54	3.97
40 (4.44)	TCG	46.00	43.60	41.10	38.70	36.20	33.60	30.90
	SDT	76.40	85.20	94.20	103.20	112.20	121.30	130.40
	KW	1.98	2.23	2.52	2.83	3.18	3.56	3.98
45 (7.22)	TCG	50.30	47.70	45.10	42.40	39.60	36.80	33.90
	SDT	78.10	86.90	95.70	104.60	113.50	122.50	131.40
	KW	2.01	2.26	2.54	2.85	3.19	3.58	4.00
50 (10.0)	TCG	54.90	52.10	49.20	46.20	43.20	40.20	37.00
	SDT	80.00	88.60	97.20	106.00	114.80	123.70	132.50
	KW	2.03	2.28	2.56	2.87	3.21	3.60	4.01
55 (12.78)	TCG	59.70	56.60	53.40	50.20	46.90	43.50	40.10
	SDT	81.90	90.30	98.90	107.50	116.20	124.90	133.60
	KW	2.06	2.30	2.58	2.89	3.23	3.62	4.03
<b>PA13NA048 – G</b>								
30 (-1.11)	TCG	39.10	37.90	36.60	35.10	33.40	31.50	29.40
	SDT	72.80	82.00	91.40	100.60	110.00	119.20	128.40
	KW	2.02	2.26	2.58	2.98	3.45	3.99	4.60
35 (1.67)	TCG	43.00	41.70	40.20	38.60	36.80	34.80	32.60
	SDT	74.20	83.40	92.60	101.90	111.10	120.30	129.40
	KW	2.04	2.29	2.61	3.01	3.49	4.03	4.64
40 (4.44)	TCG	47.20	45.80	44.20	42.40	40.50	38.30	35.90
	SDT	75.80	84.90	94.00	103.20	112.40	121.50	130.50
	KW	2.06	2.31	2.64	3.05	3.53	4.08	4.69
45 (7.22)	TCG	51.80	50.20	48.40	46.50	44.40	42.10	39.50
	SDT	77.40	86.50	95.50	104.60	113.70	122.70	131.70
	KW	2.08	2.34	2.67	3.08	3.57	4.12	4.73
50 (10.0)	TCG	56.70	54.90	53.00	50.90	48.60	46.10	43.30
	SDT	79.20	88.10	97.10	106.10	115.10	124.00	132.90
	KW	2.10	2.36	2.70	3.12	3.60	4.16	4.77
55 (12.78)	TCG	62.00	60.00	57.90	55.60	53.10	50.30	47.20
	SDT	81.10	89.90	98.80	107.70	116.60	125.40	134.20
	KW	2.11	2.38	2.73	3.14	3.63	4.19	4.81

See notes on page 17



# CONDENSER ONLY RATINGS\* CONTINUED

SST ° F (° C)		CONDENSER ENTERING AIR TEMPERATURES ° F (° C)						
		55 (12.78)	65 (18.33)	75 (23.89)	85 (29.44)	95 (35.0)	105 (40.56)	115 (46.11)
<b>PA13NA060-E</b>								
<b>30</b> <b>(-1.11)</b>	TCG	53.70	51.10	48.30	45.40	42.30	39.20	36.10
	SDT	75.80	84.90	94.10	103.10	112.20	121.30	130.40
	KW	2.65	3.00	3.38	3.78	4.24	4.77	5.38
<b>35</b> <b>(1.67)</b>	TCG	58.90	56.10	53.00	49.80	46.50	43.20	39.70
	SDT	77.50	86.60	95.70	104.70	113.60	122.60	131.60
	KW	2.72	3.06	3.43	3.84	4.29	4.82	5.44
<b>40</b> <b>(4.44)</b>	TCG	64.60	61.40	58.00	54.50	50.90	47.20	43.40
	SDT	79.40	88.40	97.30	106.20	115.10	124.00	132.90
	KW	2.79	3.13	3.50	3.90	4.35	4.88	5.50
<b>45</b> <b>(7.22)</b>	TCG	70.60	67.00	63.30	59.40	55.50	51.40	47.30
	SDT	81.40	90.30	99.10	107.90	116.70	125.40	134.20
	KW	2.87	3.20	3.56	3.97	4.42	4.95	5.56
<b>50</b> <b>(10.0)</b>	TCG	76.90	73.00	68.80	64.60	60.20	55.70	51.20
	SDT	83.50	92.20	100.90	109.60	118.30	126.90	135.60
	KW	2.95	3.29	3.64	4.04	4.50	5.03	5.64
<b>55</b> <b>(12.78)</b>	TCG	83.60	79.20	74.60	69.90	65.10	60.20	55.20
	SDT	85.80	94.30	102.90	111.40	119.90	128.50	137.00
	KW	3.05	3.38	3.73	4.13	4.59	5.12	5.73

\* AHRI listing applies only to systems shown in Combination Ratings table.

**KW** – Outdoor Unit Kilowatts Only.

**SDT** – Saturated Temperature Leaving Compressor (° F/° C)

**SST** – Saturated Temperature Entering Compressor (° F/° C)

**TCG** – Gross Cooling Capacity (1000 Btuh)

# GUIDE SPECIFICATIONS

## GENERAL

### System Description

Outdoor-mounted, air-cooled, split-system air conditioner unit suitable for ground or rooftop installation. Unit consists of a hermetic compressor, an air-cooled coil, propeller-type condenser fan, and a control box. Unit will discharge supply air upward as shown on contract drawings. Unit will be used in a refrigeration circuit to match up to a packaged fan coil or coil unit.

### Quality Assurance

- Unit will be rated in accordance with the latest edition of AHRI Standard 210.
- Unit will be certified for capacity and efficiency, and listed in the latest AHRI directory.
- Unit construction will comply with latest edition of ANSI/ASHRAE and with NEC.
- Unit will be constructed in accordance with UL standards and will carry the UL label of approval. Unit will have c-UL-us approval.
- Unit cabinet will be capable of withstanding Federal Test Method Standard No. 141 (Method 6061) 500-hr salt spray test.
- Air-cooled condenser coils will be leak tested at 150 psig and pressure tested at 450 psig.
- Unit constructed in ISO9001 approved facility.

### Delivery, Storage, and Handling

- Unit will be shipped as single package only and is stored and handled per unit manufacturer's recommendations.

### Warranty (for inclusion by specifying engineer)

- U.S. and Canada only.

## PRODUCTS

### Equipment

Factory assembled, single piece, air-cooled air conditioner unit. Contained within the unit enclosure is all factory wiring, piping, controls, compressor, refrigerant charge Puron® (R-410A), and special features required prior to field start-up.

### Unit Cabinet

- Unit cabinet will be constructed of galvanized steel, bonderized, and coated with a powder coat paint.
- All models have dense grille.

### Fans

- Condenser fan will be direct-drive propeller type, discharging air upward.
- Condenser fan motors will be totally enclosed, 1-phase type with class B insulation and permanently lubricated bearings. Shafts will be corrosion resistant.
- Fan blades will be statically and dynamically balanced.
- Condenser fan openings will be equipped with coated steel wire safety guards.

### Compressor

- Compressor will be hermetically sealed.
- Compressor will be mounted on rubber vibration isolators.

## AIR-COOLED, SPLIT-SYSTEM AIR CONDITIONER

PA13\*A

1-1/2 TO 5 NOMINAL TONS

### Condenser Coil

- Condenser coil will be air cooled.
- Coil will be constructed of aluminum fins mechanically bonded to copper tubes which are then cleaned, dehydrated, and sealed.

### Refrigeration Components

- Refrigeration circuit components will include liquid-line shutoff valve with sweat connections, vapor-line shutoff valve with sweat connections, system charge of Puron® (R-410A) refrigerant, and compressor oil.
- Unit will be equipped with filter drier for Puron refrigerant.

### Operating Characteristics

- The capacity of the unit will meet or exceed \_\_\_\_\_ Btuh at a suction temperature of \_\_\_\_\_ °F/°C. The power consumption at full load will not exceed \_\_\_\_\_ kW.
- Combination of the unit and the evaporator or fan coil unit will have a total net cooling capacity of \_\_\_\_\_ Btuh or greater at conditions of \_\_\_\_\_ CFM entering air temperature at the evaporator at \_\_\_\_\_ °F/°C wet bulb and \_\_\_\_\_ °F/°C dry bulb, and air entering the unit at \_\_\_\_\_ °F/°C.
- The system will have a SEER of \_\_\_\_\_ Btuh/watt or greater at DOE conditions.

### Electrical Requirements

- Nominal unit electrical characteristics will be \_\_\_\_\_ v, single phase, 60 hz. The unit will be capable of satisfactory operation within voltage limits of \_\_\_\_\_ v to \_\_\_\_\_ v.
- Nominal unit electrical characteristics will be \_\_\_\_\_ v, three phase, 60 hz. The unit will be capable of satisfactory operation within voltage limits of \_\_\_\_\_ v to \_\_\_\_\_ v.
- Unit electrical power will be single point connection.
- Control circuit will be 24v.

### Special Features

- Refer to section of this literature identifying accessories and descriptions for specific features and available enhancements.

## SYSTEM DESIGN

1. Intended for outdoor installation with free air inlet and outlet. Outdoor fan external static pressure available is less than 0.01-in. wc.
2. Minimum outdoor operating air temperature without low-ambient operation accessory is 55°F (12.8°C).
3. Maximum outdoor operating air temperature is 115°F (46.1°C).
4. For reliable operation, unit should be level in all horizontal planes.
5. Maximum elevation of indoor coil above or below base of outdoor unit is: indoor coil above = 80 ft (24.38 m), indoor coil below = 200 ft (60.96 m).
6. For interconnecting refrigerant tube lengths greater than 80 ft (24.38 m) horizontal or 35 ft (10.7 m) vertical differential, consult Residential Piping and Long-Line Guideline available from equipment distributor.
7. Crankcase heater required when the application qualifies as long-line.
8. If any refrigerant tubing is buried, provide a minimum 6 in (152.4 mm) vertical rise to the valve connections at the unit. Refrigerant tubing lengths up to 36 in (914.4 mm) may be buried without further consideration.
9. Use only copper wire for electric connection at unit. Aluminum and clad aluminum are not acceptable for the type of connector provided.

