



Product Data



NOTE: Images are for illustration purposes only. Actual models may differ slightly.

TABLE OF CONTENTS

	PAGE
MODEL NUMBER NOMENCLATURE	3
STANDARD FEATURES AND ACCESSORIES	4
DIMENSIONS	5
CLEARANCES	7
SPECIFICATIONS – OUTDOOR HEAT PUMP	8
COMPATIBILITY	8
PERFORMANCE	9–12
APPLICATION DATA	13
WIRING	14
AIR FLOW DATA	15
SOUND PRESSURE	15
SOUND PRESSURE IN OCTAVE BANDS	15
FAN AND MOTOR SPECIFICATIONS	16
ELECTRICAL DATA	16
WIRING DIAGRAMS	17
GUIDE SPECIFICATIONS	21

INDUSTRY LEADING FEATURES / BENEFITS

A PERFECT BALANCE BETWEEN BUDGET LIMITS, ENERGY SAVINGS AND COMFORT.

The 38MBR series ductless systems are a matched combination of an outdoor condensing unit and an indoor fan coil unit connected only by refrigerant tubing and wires.

The ductless system permits creative solutions to design problems such as:

- Add-ons to current space (an office or family room addition)
- Special space requirements
- When changes in the load cannot be handled by the existing system
- When adding air conditioning to spaces that are heated by hydronic or electric heat and have no ductwork
- Historical renovations or any application where preserving the look of the original structure is essential.

The ideal compliment to your ducted style ductless system when it is impractical or prohibitively expensive to use ductwork.

The compact indoor fan coil units take up very little space in the room and do not obstruct windows. The fan coils are attractively styled to blend with most room decors. Advanced system components incorporate innovative technology to provide reliable cooling performance at low sound levels.

Inverter Technology

The inverter driven compressor is designed to run at various input power frequencies (Hz) which controls the compressor's motor speed.

Even Temperature – The control package, including the inverter, monitors the outdoor and indoor temperatures as they relate to the selected indoor set point and adjusts the compressor speed to match the load and keep the system operating continuously rather than cycling and creating temperature swings. This translates to higher comfort levels for the occupants.

Rapid Pull Down/Warm-Up – Comfort is increased by the inverter system's ability to ramp up the compressor speed enabling the system to reach the user selected room temperature set point quicker.

Humidity Control – Running the system for longer periods and continuously varying the compressor speed enhances the humidity control.

Individual Room Comfort

Maximum comfort is provided because each space can be controlled individually based on the usage pattern.

Low Sound Levels

When noise is a concern, ductless systems are the answer. The indoor units are whisper quiet. There are no compressors indoors, either in the conditioned space or directly over it, and there is none of the noise usually generated by air being forced through the ductwork.

When sound ordinances and proximity to neighbors demand quiet operation, the 38MBR unit is the right choice. With the inverter technology, these units run at lower speeds most of the time resulting in reduced sound levels.

Inverter Technology – Enhanced Economical Operation

Ductless systems are inherently economical to operate. Individual rooms are heated or cooled only when required, and since the air is delivered directly to the space, there is no need to use additional energy to move the air in the ductwork. This economical operation is enhanced further when the inverter system output matches the load resulting in a more efficient system.

Easy-To-Use Controls

The systems have microprocessor-based controls to provide the ultimate in comfort and efficiency. The user friendly wired and wireless remote controls provide the interface between the user and the unit.

Secure Operation

If security is an issue, outdoor and indoor units are connected only by refrigerant piping and wiring to prevent intruders from crawling through ductwork or wall openings. In addition, since the 38MBR can be installed close to an outside wall, coils are protected from vandals and severe weather.

Fast Installation

This compact ductless system is simple to install. Only wires and piping need to run between the indoor and outdoor units. These units are fast and easy to install ensuring minimal disruption to customers in homes or the workplace. This makes the 38MBR systems the equipment of choice for retrofit applications.

Simple Servicing and Maintenance

Removing the top panel of the outdoor unit provides immediate access to the control compartment, providing the service technician access to the diagnostic LEDs to facilitate the troubleshooting process. In addition, the draw-thru design of the outdoor unit means that dirt accumulates on the outside surface of the coil. Coils can be cleaned quickly from the inside using a pressure hose and detergent.

On the indoor units, service and maintenance expense is reduced due to the permanent easy to clean filters. Also, error codes are displayed on the front panel to alert the user to certain system malfunctions

Built-in Reliability

Ductless system indoor and outdoor units are designed to provide years of trouble-free operation.

Both the indoor and outdoor units are well protected. Whenever the microprocessor detects abnormal conditions, the unit stops and an error code appears.

Inverter systems provide additional reliability due to the soft start. This refers to the ability of the inverter to start the compressor motor using reduced voltage and reduced current. This feature is beneficial from an electrical standpoint (eliminates current spikes) as well as an overall reliability standpoint due to reduced stress on all associated system components.

Agency Listings

All systems are listed with AHRI (Air conditioning, Heating, and Refrigeration Institute) and are ETL certified per UL 1995 standard.

MODEL NUMBER NOMENCLATURE

OUTDOOR UNIT

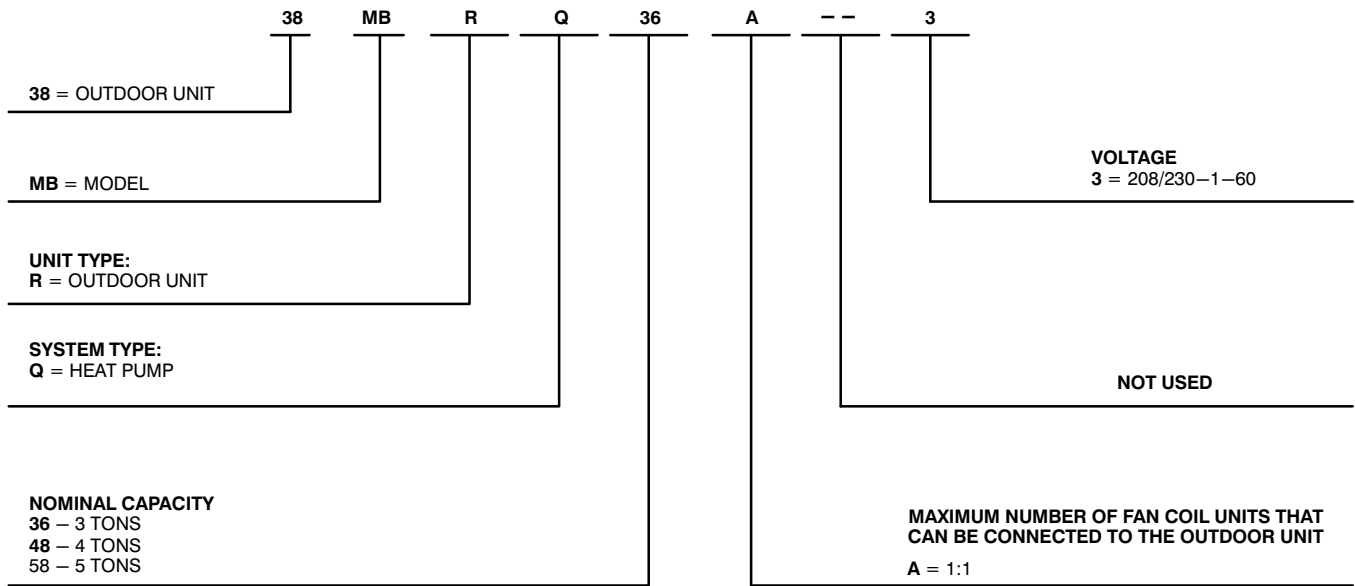

Use of the AHRI Certified TM Mark indicates a manufacturer's participation in the program. For verification of certification for individual products, go to www.ahridirectory.org.



STANDARD FEATURES AND ACCESSORIES

Ease Of Installation	
Low Voltage Controls	S
Comfort Features	
Microprocessor Controls	S
Auto Restart Function	S
Auto Changeover	S
Energy Saving Features	
Inverter Driven Compressor	S
46°F Heating Mode (Heating Setback)	S
Safety And Reliability	
3 Minute Time Delay For Compressor	S
High Compressor Discharge Temperature	S
Over Current Protection For Compressor	S
Low Voltage Protection	S
Compressor Overload Protection	S
Compressor Over Current Protection	S
IPM Module Protection	S
Condenser High Temp Protection in Cooling Mode	S
Aluminum Hydrophilic Pre-Coated Fins	S
Ease Of Service And Maintenance	
Diagnostics	S
Liquid Line Pressure Taps	S
Application Flexibility	
Crankcase Heater	S
Base pan Heater	S

Legend

- S Standard
- A Accessory

ACCESSORIES

Outdoor Unit Model Number Per Unit	Base Pan Base Rubber Plugs RCD Part Number	Quantity
38MBRQ36A--3	12600801A00117	5
38MBRQ48A--3	12600801A00118	5
38MBRQ58A--3	12600801A00118	5

NOTE: Basepan built in with multiple holes for proper draining during defrost. For applications where is required to seal these holes, and re-direct the condensate drain, rubber plugs are available through RCD.

OUTDOOR UNITS

Crankcase Heater

The crankcase heater is standard on all unit sizes. Heater clamps must be placed around the compressor oil stump.

Base pan Heater

The base pan heater is standard on all unit sizes.

DIMENSIONS

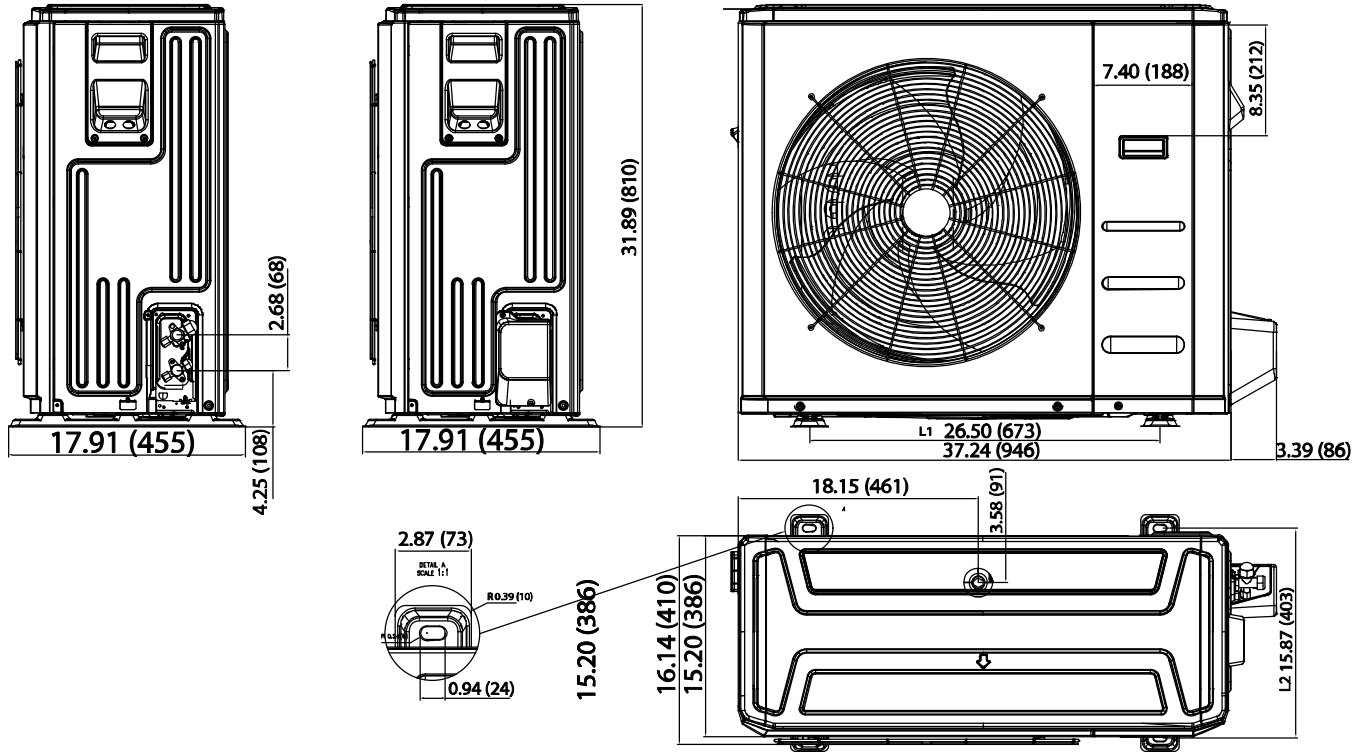

Fig. 1 – Size 36K

UNIT SIZE	WIDTH in (mm)	DEPTH in (mm)	HEIGHT in (mm)	L1 in (mm)	L2 in (mm)	OPERATING WEIGHT lb (kg)
36K	37.24 (946)	16.14 (410)	31.89 (810)	26.50 (673)	15.87 (403)	148.59 (67.4)

DIMENSIONS – (CONT)

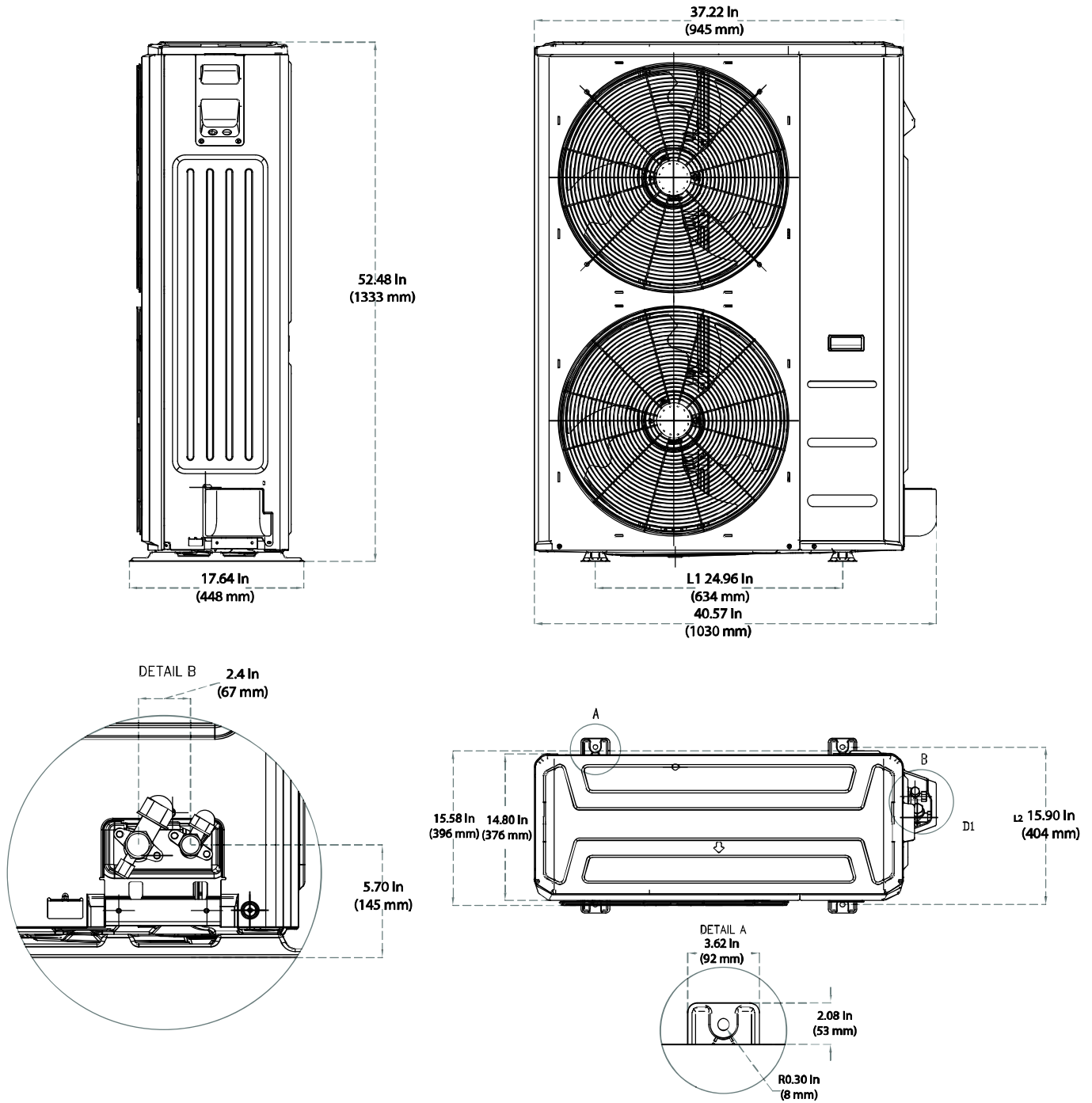

Fig. 2 – Sizes 48K–58K

UNIT SIZE	WIDTH in (mm)	DEPTH in (mm)	HEIGHT in (mm)	L1 in (mm)	L2 in (mm)	OPERATING WEIGHT lb (kg)
48K	37.22 (945)	15.58 (396)	52.48 (1333)	24.96 (634)	15.90 (404)	217.4 (98.6)
58K	37.22 (945)	15.58 (396)	52.48 (1333)	24.96 (634)	15.90 (404)	225.09 (102.1)

CLEARANCES

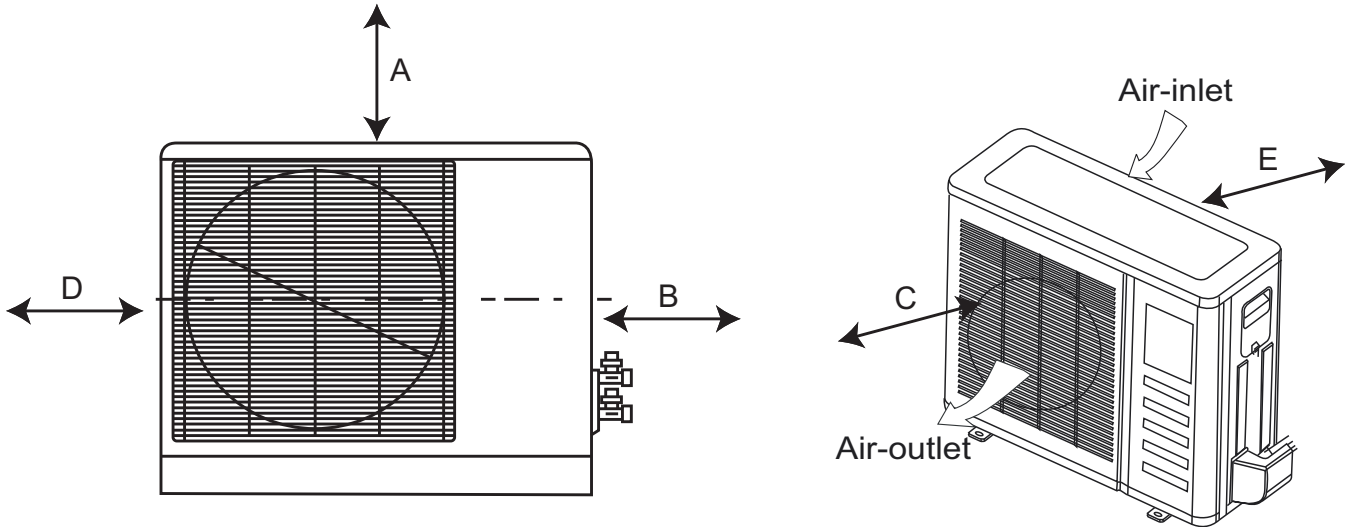

Fig. 3 – Outdoor Unit Clearance

A07894

UNIT	MINIMUM VALUE in. (mm)
A	24 (610)
B	24 (610)
C	24 (610)
D	4 (101)
E	4 (101)

NOTE: Outdoor Unit must be mounted at least 2in (50mm) above the maximum anticipated snow depth.

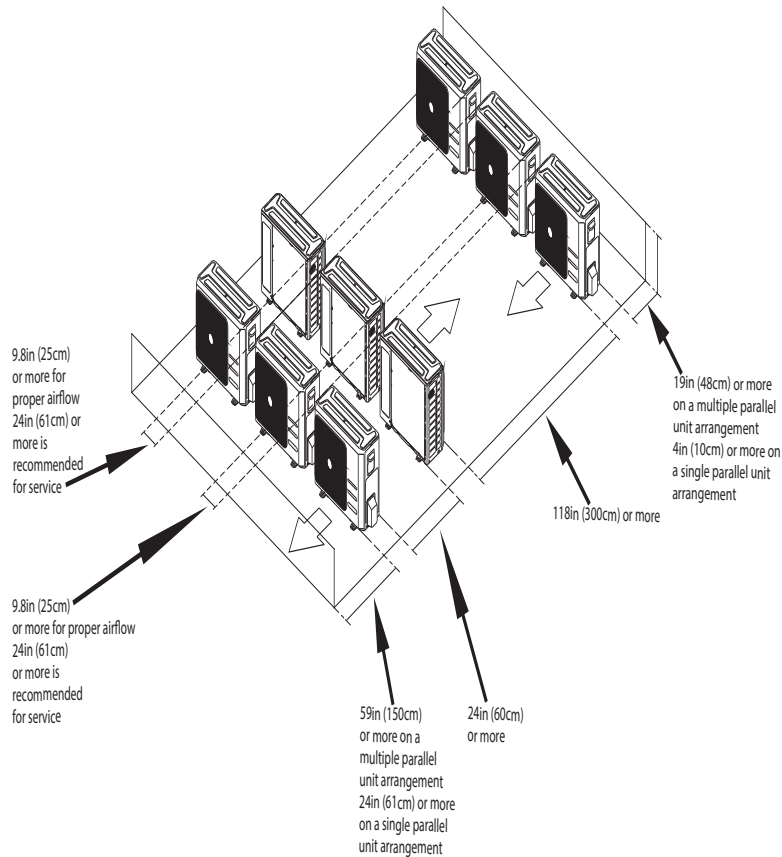

Fig. 4 – Clearances for multiple units

SPECIFICATIONS – OUTDOOR HEAT PUMP

System	Size		36	48	58
	Outdoor Model		38MBRQ36A---3	38MBRQ48A---3	38MBRQ58A---3
Electrical	Voltage, Phase, Cycle	V/Ph/Hz	208/230-1-60	208/230-1-60	208/230-1-60
	MCA	A.	30	35	35
	MOCP – Fuse Rating	A.	50	50	50
Operating Range	Cooling Outdoor DB Min – Max	° F (° C)	-13~122 (-25~50)	-13~122 (-25~50)	-13~122 (-25~50)
	Heating Outdoor DB Min – Max	° F (° C)	-22~86 (-30~30)	-22~86 (-30~30)	-22~86 (-30~30)
Piping	Total Piping Length	ft (m)	213 (65)	213 (65)	213 (65)
	Piping Lift*	ft (m)	98 (30)	98 (30)	98 (30)
	Pipe Connection Size – Liquid	in (mm)	3/8 (9.52)	3/8 (9.52)	3/8 (9.52)
	Pipe Connection Size – Suction	in (mm)	5/8 (16)	5/8 (16)	3/4 (19)
Refrigerant	Type		R410A	R410A	R410A
	Charge	lbs (kg)	6.72 (3.05)	9.26 (4.2)	10.19 (4.62)
	Metering Device		EEV	EEV	EEV
Outdoor Coil	Face Area	Sq. Ft.	8.0	13.6	13.3
	No. Rows		2	2	3
	Fins per inch		18	18	18
	Circuits		4	8	14
Compressor	Type		Rotary Inverter	Rotary Inverter	Rotary Inverter
	Model		ATF310D43UMT	ATQ420D1UMU	ATQ420D1UMU
	Oil Type		ESTER OIL VG74	ESTER OIL VG74	ESTER OIL VG74
	Oil Charge	Fl. Oz.	28.2	39.5	39.5
	Rated Current	RLA	8.9	11.9	11.9
Outdoor	Unit Width	in (mm)	37.24 (946)	37.48 (952)	37.48 (952)
	Unit Height	in (mm)	31.89 (810)	52.48 (1333)	52.48 (1333)
	Unit Depth	in (mm)	16.14 (410)	16.34 (415)	16.34 (415)
	Net Weight	lbs (kg)	148.59 (67.4)	217.4 (98.6)	225.09 (102.1)
	Airflow	CFM	2,130	4,500	4,415
	Sound Pressure	dB(A)	63.0	62.5	64.0

* Condensing unit above or below indoor unit

COMPATIBILITY

INDOOR UNIT		OUTDOOR UNIT		
		38MBRQ36A---3	38MBRQ48A---3	38MBRQ58A---3
Cassette	40MBCQ36---3	•		
	40MBCQ48---3		•	
Ducted	40MBDQ36---3	•		
	40MBDQ48---3		•	
	40MBDQ58---3			•
Console	40MBFQ36---3	•		
	40MBFQ48---3		•	
	40MBFQ58---3			•

NOTE: Backward compatible with 40MBQB*D Ducted Systems.

PERFORMANCE – CASSETTE

Cassette	Indoor Model		40MBCQ36---3	40MBCQ48---3
	Energy Star		NO	NO
	Cooling System Tons		3.0	4.0
	Cooling Rated Capacity	Btu/h	36,000	48,000
	Cooling Cap. Range Min – Max	Btu/h	8,500~38,000	9,000~50,000
	SEER		17.5	16.8
	EER		9	9.5
	Heating Rated Capacity (47°F)	Btu/h	38,000	50,000
	Heating Rated Capacity (17°F)	Btu/h	25,200	35,000
	Heating Capacity (5°F)	Btu/h	25,300	34,000
	Heating Cap. Range Min – Max	Btu/h	9,500~50,000	10,000~55,000
	HSPF		10.5	11.0
	COP (47°F)	W/W	3	3.6
	COP (17°F)	W/W	2.46	2.62
	COP (5°F)	W/W	1.71	1.84

PERFORMANCE – DUCTED

Ducted	Indoor Model		40MBDQ36---3	40MBDQ48---3	40MBDQ58---3
	Energy Star		NO	NO	NO
	Cooling System Tons		3.0	4.0	4.8
	Cooling Rated Capacity	Btu/h	36,000	48,000	57,000
	Cooling Cap. Range Min – Max	Btu/h	8,500~38,000	9,000~50,000	18,000~58,000
	SEER		16.5	17.4	18
	EER		9	9.2	10
	Heating Rated Capacity (47°F)	Btu/h	40,000	49,500	62,000
	Heating Rated Capacity (17°F)	Btu/h	27,600	33,400	37,600
	Heating Capacity (5°F)	Btu/h	25,300	34,000	35,000
	Heating Cap. Range Min – Max	Btu/h	9,500~50,000	10,000~55,000	12,000~63,000
	HSPF		11.5	10.3	9.0
	COP (47°F)	W/W	3	3.6	3.6
	COP (17°F)	W/W	2.46	2.62	2.62
	COP (5°F)	W/W	1.71	1.84	1.91

PERFORMANCE – CONSOLE

Console	Indoor Model		40MBFQ36---3	40MBFQ48---3	40MBFQ58---3
	Energy Star		NO	NO	NO
	Cooling System Tons		3.0	4.0	4.5
	Cooling Rated Capacity	Btu/h	36,000	48,000	54,000
	Cooling Cap. Range Min – Max	Btu/h	8,500~38,000	9,000~50,000	18,000~58,000
	SEER		16	17.8	18
	EER		8	9.3	9.8
	Heating Rated Capacity (47°F)	Btu/h	38,000	50,000	60,000
	Heating Rated Capacity (17°F)	Btu/h	25,400	35,000	39,000
	Heating Capacity (5°F)	Btu/h	25,300	34,000	35,000
	Heating Cap. Range Min – Max	Btu/h	9,500~50,000	10,000~55,000	12,000~63,000
	HSPF		10.0	11.0	10.5
	COP (47°F)	W/W	3	3.6	3.6
	COP (17°F)	W/W	2.46	2.62	2.62
	COP (5°F)	W/W	1.71	1.84	1.91

COOLING PERFORMANCE DATA – CASSETTE

Model	Cooling			Outdoor Conditions (DB)											
	Indoor Conditions DB		TC	-13F (-25C)	-4F (-20C)	0F (-17C)	5F (-15C)	17F (-8C)	47F (8C)	77F (25C)	86F (30C)	95F (35C)	104F (40C)	113F (45C)	122F (50C)
	DB	WB													
36 (208-230V)	69.8F (21C)	59F (15C)	TC	39.08	40.29	35.08	34.44	32.06	28.95	30.14	29.87	27.33	23.40	16.86	13.93
			SC	27.46	28.31	25.68	25.22	23.52	22.41	22.67	22.56	21.49	19.54	16.56	11.95
			Input	3.29	3.43	2.00	1.74	1.69	1.46	2.58	3.48	3.62	3.20	2.37	1.99
	75.2F (24C)	62.6F (17C)	TC	41.21	42.49	46.07	45.00	46.84	30.64	32.44	32.20	29.49	25.16	18.30	15.50
			SC	28.88	29.77	31.29	31.56	33.58	23.90	24.31	24.18	23.12	21.09	18.02	13.73
			Input	3.55	3.70	3.09	3.31	3.46	1.49	2.62	6.52	3.70	3.26	2.39	2.00
	80.6F (27C)	66.2F (19C)	TC	48.57	50.07	48.72	47.41	49.52	32.60	34.99	34.89	36.86	27.18	19.91	16.96
			SC	32.38	33.38	32.61	32.08	46.29	25.38	25.84	25.78	26.73	22.62	19.45	15.37
			Input	2.98	3.11	3.29	3.29	3.48	1.52	2.67	3.35	3.78	3.31	2.41	1.98
	89.6F (32C)	73.4F (23C)	TC	52.85	54.49	53.63	52.23	53.96	38.45	40.82	39.88	38.41	31.62	22.96	18.45
			SC	32.46	33.46	33.06	32.71	50.56	27.12	27.35	26.98	27.50	24.13	21.04	18.29
			Input	3.49	3.64	3.73	3.45	3.53	2.70	2.77	3.59	3.95	3.43	2.43	2.55
48 (208-230V)	69.8F (21C)	59F (15C)	TC	42.19	43.49	46.27	46.56	53.19	51.17	47.34	44.97	41.93	31.32	25.08	19.83
			SC	30.78	31.73	33.05	33.13	36.38	35.26	33.36	32.30	30.79	25.81	22.88	19.49
			Input	3.15	3.28	3.46	3.51	3.20	3.64	4.74	5.10	5.21	3.63	3.33	3.15
	75.2F (24C)	62.6F (17C)	TC	44.51	45.89	48.82	49.65	56.96	52.38	49.37	48.10	45.14	33.86	28.26	21.92
			SC	32.19	33.18	34.57	34.98	38.40	36.28	34.09	34.19	32.73	27.80	25.27	21.48
			Input	3.30	3.44	3.62	3.64	3.35	3.55	4.70	5.16	5.29	3.66	3.37	3.18
	80.6F (27C)	66.2F (19C)	TC	47.66	49.13	52.27	54.00	60.60	53.28	51.14	50.11	48.44	37.42	27.46	27.12
			SC	33.74	34.78	36.23	37.15	60.58	36.77	35.86	35.40	34.27	31.58	25.66	26.42
			Input	3.43	3.57	3.76	3.76	3.48	3.55	4.77	5.21	5.35	3.68	3.41	3.78
	89.6F (32C)	73.4F (23C)	TC	53.00	54.64	58.13	60.55	66.57	62.30	52.17	51.79	49.13	36.21	34.64	31.87
			SC	33.61	34.65	36.09	37.99	40.18	38.52	34.43	34.34	31.75	29.68	22.74	28.46
			Input	3.42	3.56	3.74	3.98	3.69	4.06	4.80	5.27	5.52	3.16	1.51	3.85

LEGEND

DB – Dry Bulb
 WB – Wet Bulb
 TC – Total Net Capacity (1000 Btu/hour)
 SC – Sensible Capacity (1000 Btu/hour)
 Input – Total Power (kW)

HEATING PERFORMANCE DATA – CASSETTE

Model	Heating			Outdoor Conditions (DB)											
	Indoor Conditions DB		TC	-22F (-30C)	-13F (-25C)	-4F (-20C)	0F (-17C)	5F (-15C)	17F (-8C)	19.4F (-7C)	24.8F (-4C)	32F (0C)	39.2F (4C)	44.6F (7C)	53.6F (12C)
	DB	WB													
36 (208-230V)	59F (15C)	59F (15C)	TC	14.51	18.12	21.60	25.47	25.96	29.58	27.92	32.37	34.88	37.44	39.89	40.33
			Input	3.15	3.26	3.34	3.37	3.39	3.32	3.08	3.36	3.39	3.07	3.05	2.72
			COP	1.35	1.63	1.89	2.21	2.25	2.61	2.66	2.82	3.01	3.58	3.83	4.34
	64.4F (18C)	64.4F (18C)	TC	15.43	19.25	22.71	22.15	25.66	29.93	30.97	33.18	35.60	36.37	40.98	39.05
			Input	2.94	3.11	3.36	3.15	3.43	3.52	3.32	3.43	3.45	3.20	3.27	2.84
			COP	1.54	1.82	1.98	2.06	2.19	2.49	2.74	2.83	3.02	3.33	3.68	4.03
	69F (20.5C)	69F (20.5C)	TC	15.20	19.11	22.39	23.90	25.19	30.49	30.39	33.04	34.70	36.23	40.14	38.20
			Input	2.94	3.22	3.47	3.59	3.53	3.56	3.42	3.57	3.56	3.34	3.38	2.94
			COP	1.52	1.74	1.89	1.95	2.09	2.51	2.60	2.71	2.86	3.18	3.48	3.81
	71.6F (22C)	71.6F (22C)	TC	12.24	14.74	17.76	19.64	20.81	25.76	26.93	29.90	32.62	36.64	39.90	38.00
			Input	2.25	2.41	2.58	2.68	2.75	2.89	2.96	3.10	3.25	3.46	3.47	3.09
			COP	1.59	1.79	2.02	2.15	2.21	2.61	2.67	2.82	2.95	3.10	3.37	3.60
48 (208-230V)	59F (15C)	59F (15C)	TC	20.68	26.76	33.02	28.15	39.50	46.28	46.40	49.18	56.48	61.03	57.65	57.16
			Input	5.01	5.15	5.13	4.43	5.37	5.45	5.21	5.82	5.4	5.48	4.93	4.2
			COP	1.21	1.52	1.89	1.86	2.16	2.49	2.61	2.48	3.07	3.26	3.43	3.99
	64.4F (18C)	64.4F (18C)	TC	21.03	27.27	32.23	35.93	37.90	47.55	46.77	49.71	55.46	60.17	56.59	55.71
			Input	5	5.14	5.29	5.56	5.47	5.61	5.31	5.72	5.62	5.7	5.16	4.39
			COP	1.23	1.56	1.79	1.9	2.03	2.48	2.58	2.55	2.89	3.09	3.21	3.72
	69F (20.5C)	69F (20.5C)	TC	21.36	27.76	31.52	35.38	36.91	45.68	45.87	50.60	54.40	58.94	56.11	54.67
			Input	4.90	5.01	5.52	5.75	5.68	5.68	5.46	5.56	5.81	5.89	5.39	4.55
			COP	1.28	1.63	1.67	1.80	1.90	2.36	2.46	2.67	2.74	2.93	3.05	3.52
	71.6F (22C)	71.6F (22C)	TC	20.98	27.07	31.53	34.80	36.40	45.13	44.36	51.88	53.86	56.93	55.91	60.26
			Input	4.91	5.01	5.56	5.89	5.72	5.85	5.48	5.37	5.94	5.89	5.53	4.99
			COP	1.25	1.58	1.66	1.73	1.86	2.26	2.37	2.83	2.66	2.83	2.96	3.54

LEGEND

DB – Dry Bulb
 WB – Wet Bulb
 TC – Total Net Capacity (1000 Btu/hour)
 Input – Total Power (kW)
 COP – W/W

APPLICATION DATA

UNIT SELECTION

Select equipment that either matches or supports slightly more than the anticipated peak load. This provides better humidity control, fewer unit cycles, and less part-load operation.

For units used in spaces with high sensible loads, base equipment selection on unit sensible load, not on total anticipated load. Adjust for anticipated room wet bulb temperature to avoid undersizing the equipment.

UNIT MOUNTING (OUTDOOR)

Refer to the unit's installation instructions for further details.

Unit leveling – For reliable operation, units should be level in all planes.

Clearance – Minimum clearance (see Fig. 3) must be provided for airflow. The condensing units are designed for free-flow application. Air inlets and outlets should not be restricted.

Unit location – A location which is convenient to installation and not exposed to strong winds. A location that can bear the weight of the outdoor unit and where the outdoor unit can be mounted in a level position.

Do not install the indoor or outdoor units in a location with special environmental conditions. For those applications, contact your sales representative.

SYSTEM OPERATING CONDITIONS

OPERATING RANGE MIN / MAX °F (°C)		
	COOLING	HEATING
Outdoor DB	-13~122 (-25~50)	-22~86 (-30~30)

NOTE: Reference the product installation instructions for more information.

METERING DEVICES

The outdoor unit has an electronic expansion valve to manage the refrigerant flow of the connected fan coil.

DRAIN CONNECTIONS

Install drains to meet the local sanitation codes.

REFRIGERANT LINES

General refrigerant line sizing:

1. The outdoor units are shipped with a full charge of R410A refrigerant. All charges, line sizing, and capacities are based on runs of 25 ft. (7.6 m). For runs over 25 ft. (7.6 m), review the *Long Line Applications* section for the proper charge adjustments.
2. Refrigerant lines should not be buried in the ground. If it is necessary to bury the lines, do not bury more than 36-in (914 mm). Provide a minimum 6-in (152 mm) vertical rise to the service valves to prevent refrigerant migration.
3. Both lines must be insulated. Use a minimum of 1/2-in. (12.7 mm) thick insulation. Closed-cell insulation is recommended in all long-line applications.
4. Special consideration should be given to isolating the interconnecting tubing from the building structure. Isolate the tubing so vibration or noise is not transmitted into the structure.

Long Line Applications:

1. No change in line sizing is required.
2. Add refrigerant per the Additional Charge table.

ADDITIONAL CHARGE

UNIT SIZE	TOTAL LINE LENGTH ft		ADDITIONAL CHARGE, oz/ft. Ft (m)	
	Min	Max	>10–25 (3–8)	>25–213 (8–65)
36K	10	213	None	0.43
48K				
58K				

WIRING

All wires must be sized per NEC (National Electrical Code) or CEC (Canadian Electrical Code) and local codes. Use Electrical Data table MCA (minimum circuit amps) and MOCP (maximum over current protection) to correctly size the wires and the disconnect fuse or breakers respectively.

SIZES 36–58 RECOMMENDED CONNECTION METHOD FOR POWER AND COMMUNICATION WIRING

Power and Communication Wiring:

The main power is supplied to the outdoor unit. The field supplied power wiring from the outdoor unit to the indoor unit consists of three (3) wires and provides the power for the indoor unit. Two wires are high voltage AC power and one is a ground wire. To minimize voltage drop, the factory recommended wire size is 14/2 stranded with a ground.

Communication Wiring:

A separate shielded stranded copper conductor only, with a 600 volt rating and double insulated copper wire, must be used as the communication wire from the outdoor unit to the indoor unit. Please use a separate shielded 16GA stranded control wire.



CAUTION

EQUIPMENT DAMAGE HAZARD

Failure to follow this caution may result in equipment damage or improper operation.

Wires should be sized based on NEC and local codes.



CAUTION

EQUIPMENT DAMAGE HAZARD

Failure to follow this caution may result in equipment damage or improper operation.

Be sure to comply with local codes while running wire from the indoor unit to the outdoor unit.

Every wire must be connected firmly. Loose wiring may cause the terminal to overheat or result in unit malfunction. A fire hazard may also exist. Ensure all wiring is tightly connected.

No wire should touch the refrigerant tubing, compressor or any moving parts.

Disconnecting means must be provided and shall be located within sight and readily accessible from the air conditioner.

Connecting cable with conduit shall be routed through the hole in the conduit panel.

AIR FLOW DATA

SYSTEM SIZE	36K	48K	58K
Outdoor (CFM)	2,130	4,500	4,415

SOUND PRESSURE

SYSTEM SIZE		36K	48K	58K
Outdoor sound pressure level	dBa	63	62.5	64

SOUND PRESSURE IN OCTAVE BANDS

SIZE	Frequency (Hz)	63	125	250	500	1000	2000	4000	8000
36K	Cooling dB(A)	51.3	59.2	56.3	51.3	49.4	46.8	42.6	35.7
	Heating dB(A)	53.8	62.3	60.8	53.7	52.0	48.4	45.8	37.8
48K	Cooling dB(A)	59.2	61.6	55.9	58.1	59.6	51.9	47.8	43.8
	Heating dB(A)	65.1	66.1	61.3	59.7	58.2	54.1	47.5	43.6
58K	Cooling dB(A)	22.9	41.3	46.6	50.1	50.8	52.6	46.0	40.4
	Heating dB(A)	30.0	46.8	48.4	52.0	54.3	52.8	43.7	41.3

OUTDOOR UNIT SOUND PRESSURE TEST CONDITIONS

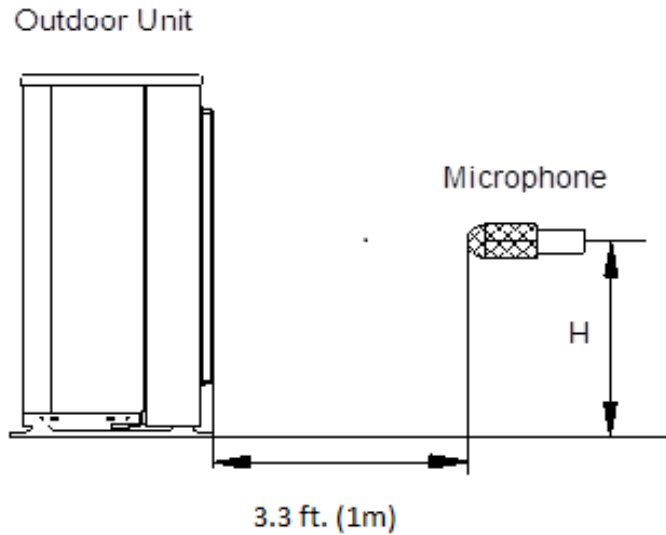

NOTE: H=0.5 x Height of outdoor unit

	INDOOR CONDITION		OUTDOOR CONDITION	
	DB	WB	DB	WB
Cooling	80.6F (27C)	66.2F (19C)	95F (35C)	75.2F (24C)
Heating	68F (20C)	59F (15C)	44.6F (7C)	42.8F (6C)

FAN AND MOTOR SPECIFICATIONS

SYSTEM SIZE			36K	48K	58K
Outdoor Fan Propeller	Material	--	AS	AS	AS
	Type	--	ZL-560*139*12-3KN	ZL-554*148*12-3KFN	ZL-554*148*12-3KFN
	Diameter	in	22.05 (560)	21.81 (554)	21.81 (554)
	Height	in	5.47 (139)	5.83 (148)	5.83 (148)
Outdoor Fan Motor	Model	--	WZDK120-38G-W	ZKFN-85-8-22	ZKFN-85-8-22
	Type	--	DC	DC	DC
	Phase	--	1	1	1
	FLA	A	1.21	1.17	1.17
	Insulation Class	--	E	E	E
	Safe Class	--	IPX0	IPX0	IPX0
	Input	W	150	126	126
	Output	W	120	85	85
	Range of current	A	1.21±10%	1.17±10%	1.17±10%
	Rated current	A	1.21	1.17	1.17
	Capacitor	μF	N/A	N/A	N/A
	Rated HP	HP	0.16	0.14	0.14
	Speed	rev/min	850/800/750	900/850/750	900/850/750
	Rated RPM	rev/min	1050	900	900
Max. input	W	150	126	126	

ELECTRICAL DATA

OUTDOOR UNIT SIZE		36K	48K	58K
Power Supply	Volts-PH-Hz	208/230-1-60	208/230-1-60	208/230-1-60
	Max - Min* Oper. Voltage	253-187	253-187	253-187
	MCA	30	35	35
	Max Fuse/CB AMP	50	50	50
Compressor	Volts-PH-Hz	208/230-1-60	208/230-1-60	208/230-1-60
	RLA	8.85	11.86	11.86

*Permissible limits of the voltage range at which the unit will operate satisfactorily.

LEGEND

MCA – Minimum Circuit Amps

RLA – Rated Load Amps

WIRING DIAGRAMS

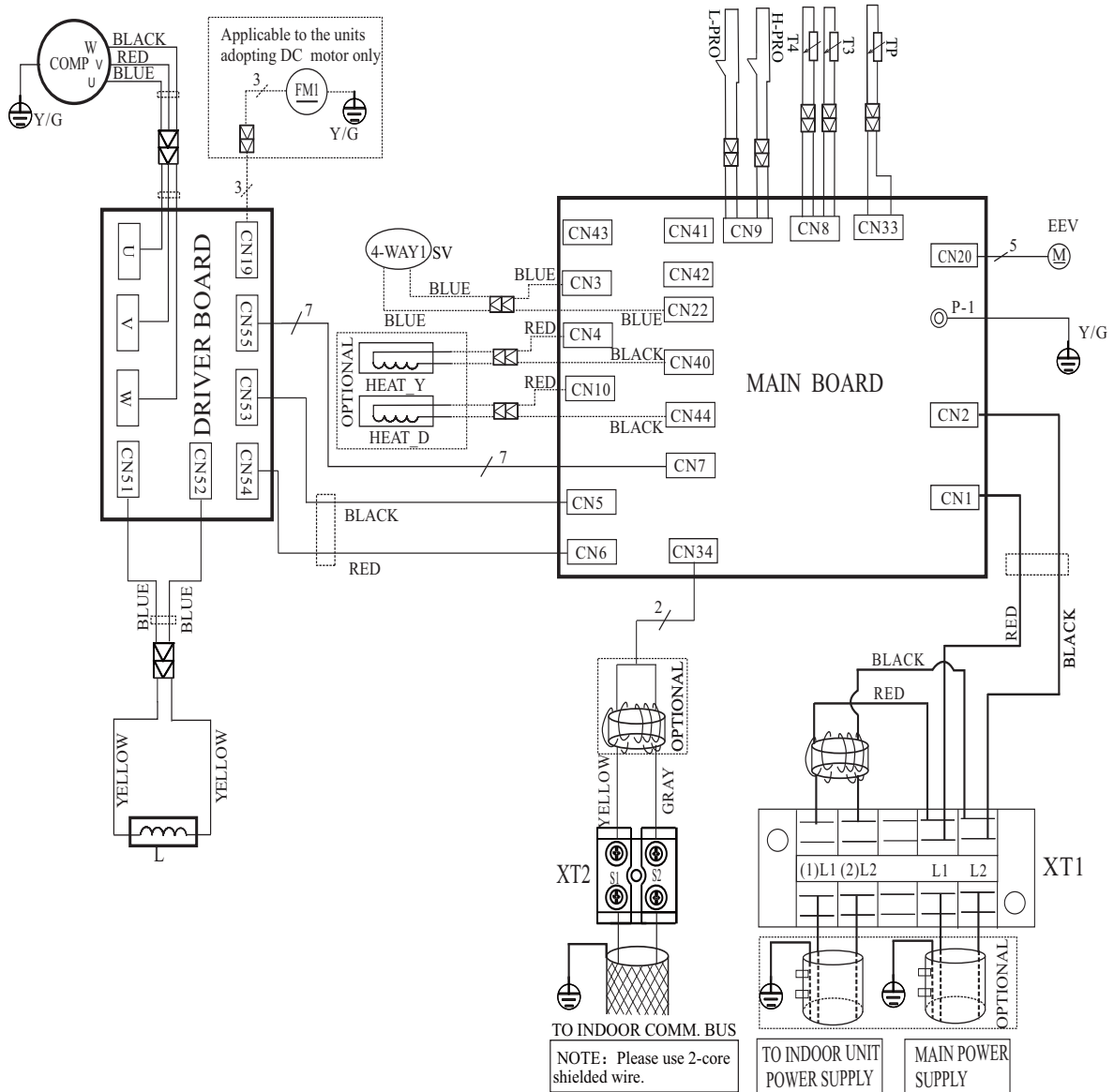

Fig. 5 – Wiring Diagram Size 36K

WIRING DIAGRAMS (CONT)

OUTDOOR UNIT MAIN BOARD	
CODE	PART NAME
CN1~CN2	Input: 230VAC High voltage
CN5~CN6	Output: 230VAC High voltage
P-1	Connection to the earth
CN10~CN44	Output: 230VAC High voltage Chassis Crankcase Heater
CN4~CN40	Output: 230VAC High voltage Compressor Crankcase Heat
CN3~CN22	Output: 230VAC High voltage
CN43	Output: Pin3~Pin2, Pin4~Pin2 (230 VAC High voltage) For AC FAN
CN41~CN42	Output To AC FAN Capacitor
CN34	Output: -24VDC-24VDC
CN33	Input: Pin 1 (0-5VDC), Pin 2 (5VDC) Discharge Temperature Sensor
CN8	Input: Pin3, Pin4 (5VDC), Pin2 (0VDC), Pin1, Pin5 (0-5VDC) T3 & T4
CN9	Input: Pin2, Pin4 (0VDC), Pin1, Pin3 (0-5VDC) H/L Pressure Switch
CN20	Output: Pin1-Pin4: Pulse waveform(0-12VDC), Pin5, Pin6 (12VDC)
CN7	Output: Pin1 (12VDC), Pin2 (5VDC), Pin3 (EARTH)

OUTDOOR UNIT PFC & IPM BOARD	
CODE	PART NAME
CN53~CN54	Input: 230VAC High voltage
CN55	Output: Pin1 (12VDC), Pin2 (5VDC), Pin3 (EARTH)
CN19	Pin1~Pin3: Connect to FAN voltage among phases 0~200VAC
U~V~W	Connect to compressor voltage among phases 0~200VAC
CN51~CN52	CN51~EARTH, CN52~EARTH Output: 224-380VDC High voltage

CODE	PART NAME	CODE	PART NAME
COMP	COMPRESSOR	L	PFC INDUCTOR
CAP1	FAN MOTOR CAPACITOR	L-PRO	LOW PRESSURE SWITCH
HEAT	CRANKCASE HEATING	H-PRO	HIGH PRESSURE SWITCH
FM1	OUTDOOR DC FAN	SV	4-WAY VALVE
FAN1	OUTDOOR AC FAN	T3	CONDENSER TEMPERATURE SENSOR
EEV	ELECTRONIC EXPANSION VALVE	T4	OUTDOOR AMBIENT TEMPERATURE SENSOR

WIRING DIAGRAMS (CONT)

Notes: -----

This symbol indicates the element is optional, the actual shape shall be prevail.

WIRING DIAGRAM (OUTDOOR UNIT) 16022500003306

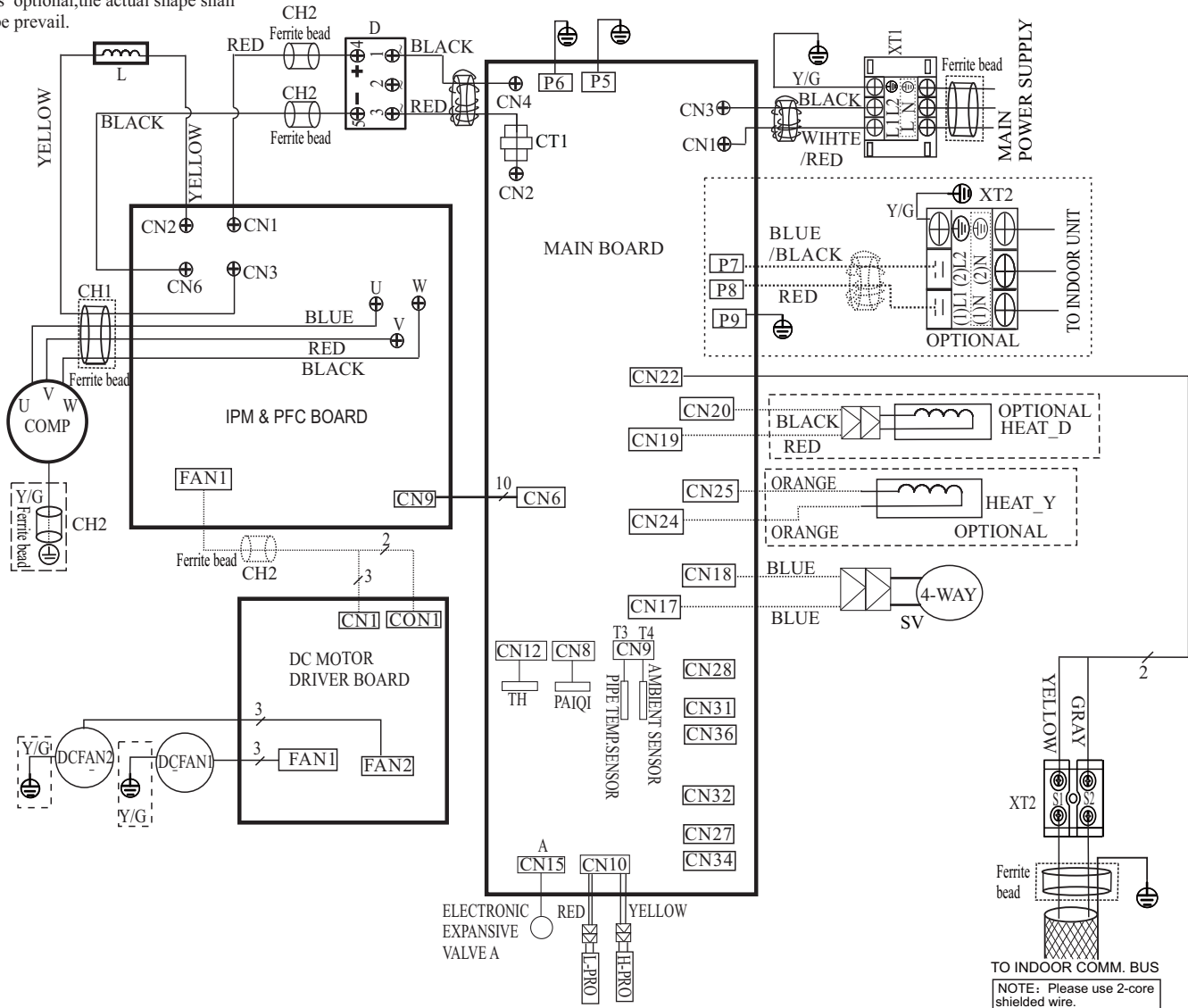

Fig. 6 – Wiring Diagram – Sizes 48K and 58K

OUTDOOR UNIT MAIN BOARD	
CODE	PART NAME
CN1~CN3	Input: 230VAC High voltage
P7~P8	Output: 230VAC High voltage to IDU
P5,P6,P9	Connection to the earth
CN22	Output: -24VDC-24VDC for IDU Communication
CN17~CN18	Output: 230VAC High voltage 4 way valve
CN19~CN20	Output: 230VAC High voltage Chassis Crankcase Heater
CN24~CN25	Output: 230VAC High voltage Compressor Crankcase Heater
CN2~CN4	Output: 230VAC High voltage to AC CURRENT DETECTOR
CN12	Input: Pin1 (0-5VDC),Pin2 (5VDC) Heatsink Temperature Sensor
CN8	Input: Pin1 (0-5VDC),Pin2 (5VDC) Compressor Top Sensor(PAIQI)
CN9	Input: Pin3,Pin4 (5VDC),Pin2 (0VDC),Pin1,Pin5 (0-5VDC) the ambient sensor and pipe sensor
CN10	Input: Pin2, Pin4 (0VDC),Pin1,Pin3 (0-5VDC) for the H/L pressure switch
CN15	Output: Pin1-Pin4: Pulse waveform (0-12VDC),Pin5, Pin6 (12VDC) EEV
CN6	Output: Pin1-Pin6: Pulse waveform (0-5VDC), Pin7, Pin9 (0VDC) Pin8 (0-5VDC), Pin10 (5VDC)

WIRING DIAGRAMS (CONT)

OUTDOOR UNIT PFC & IPM BOARD	
CODE	PART NAME
CN1~CN6	Output:224~380VDC High voltage to DIODE MODULE
CN2~CN3	Output:224~380VDC High voltage to PFC INDUCTOR
U~V~W	Connection to compressor voltage among phases 0~200VAC
CN9	Input:Pin1~Pin6: Pulse waveform (0~5VDC),Pin7, Pin9 (0VDC) Pin8 (0~5VDC),Pin10 (5VDC)
FAN1	Output: Pin1~Pin2: High voltage (224~380VDC), Pin4 (0~15VDC) Pin5 (0~5.6VDC), Pin6:Pulse waveform (0~15VDC)

OUTDOOR UNIT DC MOTOR DRIVER BOARD	
CODE	PART NAME
CON1	Output:Pin1~Pin2:High voltage (224~380VDC)
CN1	Input: Pin4: Pulse waveform (0~15VDC) ,Pin3 (0~6.5VDC) Pin2 (0VDC),Pin1 (15VDC)
FAN1	Pin1~Pin3: Connect to FAN voltage among phases 0~200VAC
FAN2	Pin1~Pin3: Connect to FAN voltage among phases 0~200VAC

CODE	PART NAME
COMP	COMPRESSOR
CAP1,CAP2	FAN MOTOR CAPACITOR
CT1	AC CURRENT DETECTOR
D	DIODE MODULE
EEV	ELECTRONIC EXPANSION VALVE
FM1,FM2	OUTDOOR DC FAN
FAN1,FAN2	OUTDOOR AC FAN
HEAT	CRANKCASE HEATING
H~PRO	HIGH PRESSURE SWITCH
L	PFC INDUCTOR
L~PRO	LOW PRESSURE SWITCH
KM	AC CONTACTOR
SV	4~WAY VALVE
TP	EXHAUST TEMPERATURE SENSOR
T3	CONDENSER TEMPERATURE SENSOR
T4	OUTDOOR AMBIENT TEMPERATURE SENSOR
TH	HEATSINK TEMPERATURE SENSOR
PAIQI	COMPRESSOR TOP SENSOR (GAS PIPE SENSOR)
CH 1 CH 2 CH 3	FERRITE BEAD

GUIDE SPECIFICATIONS

HORIZONTAL DISCHARGE OUTDOOR UNITS

Size Range: 3 to 5 Ton Nominal Cooling and Heating Capacity
Model Number: 38MBR

PART 1 – GENERAL

1.01 System Description

- A. Outdoor air-cooled split system compressor sections suitable for on-the-ground, rooftop, wall hung or balcony mounting. Units consist of a rotary compressor, an air-cooled coil, propeller-type draw-through outdoor fan, reversing valve (HP), accumulator (HP units), metering device(s), and a control box. Units discharge air horizontally as shown on the contract drawings. Units function as the outdoor component of an air-to-air heat pump system.
- B. Units are to be used in a refrigeration circuit matched to ductless heat pump fan coil units.

1.02 Agency Listings

- A. Unit construction complies with ANSI/ASHRAE 15, latest revision, and with the NEC.
- B. Units are evaluated in accordance with UL standard 1995.
- C. Units are listed in the CEC directory.
- D. Unit cabinet is capable of withstanding 500-hour salt spray test per Federal Test Standard No. 141 (method 6061).
- E. Air-cooled condenser coils are leak tested at 550 psig.

1.03 Delivery, Storage, And Handling

Units are shipped in one piece and are stored and handled per unit manufacturer's recommendations.

1.04 Warranty (For Inclusion By Specifying Engineer)

PART 2 – PRODUCTS

2.01 Equipment

A. General:

Factory assembled, single piece, air-cooled outdoor unit. Contained within the unit enclosure is all the factory wiring, piping, controls, and the compressor.

B. Unit Cabinet:

- 1. Unit cabinet is constructed of galvanized steel, bonderized and coated with a baked-enamel finish on the inside and outside.
- 2. Unit access panels is removable with minimal screws and provides full access to the compressor, fan, and control components.
- 3. The outdoor compartment is isolated and has an acoustic lining to assure quiet operation.

C. Fans:

- 1. Outdoor fans are the direct drive propeller type, and discharges air horizontally. Fans draw air through the outdoor coil.
- 2. Outdoor fan motors are totally enclosed, single phase motors with class E insulation and permanently lubricated ball bearings. Motor shall be protected by internal thermal overload protection.
- 3. The shaft has inherent corrosion resistance.
- 4. Fan blades are non-metallic and statically and dynamically balanced.
- 5. Outdoor fan openings are equipped with a PVC metal/mesh coated protection grille over the fan.

D. Compressor:

- 1. Compressor is the fully hermetic rotary type.
- 2. Compressor is equipped with an oil system, operating oil charge, and a motor.
- 3. Motor is NEMA rated class E, suitable for operation in a refrigerant atmosphere.
- 4. Compressor assembly is installed on rubber vibration isolators.

E. Outdoor Coil:

The coil is constructed of aluminum hydrophilic pre-coated fins mechanically bonded to seamless copper tubes, which are cleaned, dehydrated, and sealed.

F. Refrigeration Components:

Refrigerant circuit components include a brass external liquid line service valve with service gage port connections, a suction line service valve with a service gage connection port, service gage port connections on compressor suction and discharge lines with Schrader type fittings with brass caps, accumulator, reversing valve.

G. Controls and Safeties:

Operating controls and safeties are factory selected, assembled, and tested. The minimum control functions include the following:

- 1. Controls:
 - a. A time delay control sequence is provided standard through the fan coil board
 - b. Automatic outdoor fan motor protection.
- 2. Safeties:
 - a. System diagnostics
 - b. Compressor motor current and temperature overload protection
 - c. Outdoor fan failure protection.

H. Electrical Requirements:

- 1. Unit operates on single-phase, 60 Hz power at 208/230V as specified.
- 2. Unit electrical power has a single point connection.
- 3. Unit Control voltage to the indoor fan coil is 0-15V DC.
- 4. All power and control wiring must be installed per NEC and all local electrical codes.
- 5. The unit has high and low voltage terminal block connections.

