

FX4D FAN COILS

Installation Instructions

NOTE: Read the entire instruction manual before starting the installation.

SAFETY CONSIDERATIONS

Improper installation, adjustment, alteration, service, maintenance, or use can cause explosion, fire, electrical shock, or other conditions which may cause death, personal injury or property damage. Consult a qualified installer, service agency, or your distributor or branch for information or assistance. The qualified installer or agency must use factory-authorized kits or accessories when modifying this product. Refer to the individual instructions packaged with kits or accessories when installing.

Follow all safety codes. Wear safety glasses, protective clothing and work gloves. Have a fire extinguisher available. Read these instructions thoroughly and follow all warnings or cautions included in literature and attached to the unit. Consult local building codes and the current editions of the National Electrical Code (NEC) NFPA 70.

In Canada, refer to the current editions of the Canadian Electrical Code CSA C22.1.

Recognize safety information. This is the safety-alert symbol . When you see this symbol on the unit and in instruction manuals, be alert to the potential for personal injury.

Understand the signal words **DANGER**, **WARNING**, and **CAUTION**. These words are used with the safety-alert symbol. **DANGER** identifies the most serious hazards which **will** result in severe personal injury or death. **WARNING** signifies hazards which **could** result in personal injury or death. **CAUTION** is used to identify unsafe practices which **may** result in minor personal injury or product and property damage. **NOTE** is used to highlight suggestions which **will** result in enhanced installation, reliability, or operation.

WARNING

ELECTRICAL OPERATION HAZARD

Failure to maintain proper clearances could result in personal injury or death.

Before installing or servicing unit, always turn off all power to unit. There may be more than 1 disconnect switch. Turn off accessory heater power if applicable. Lock out and tag switch with a suitable warning label.

CAUTION

CUT HAZARD

Failure to follow this caution may result in personal injury. Sheet metal parts may have sharp edges or burrs. Use care and wear appropriate protective clothing, safety glasses and gloves when handling parts.

INTRODUCTION

Model FX4D is designed for flexibility and can be used for upflow, horizontal, or downflow (kit required) and manufactured and mobile home applications. These units are designed to meet the low air leak requirements currently in effect. Because of this, the units need special

attention in the condensate pan and drain connection area and when brazing tubing. These units are designed specifically for Puron refrigerant and must be used only with Puron refrigerant air conditioners and heat pumps as shipped. These units are available for systems of 18,000 through 60,000 Btuh nominal cooling capacity. Factory-authorized, field-installed electric heater packages are available in sizes 5 through 30kW. See Product Data literature for available accessory kits.

HEATER PACKAGES

This unit may or may not be equipped with an electric heater package. For units not equipped with factory-installed heat, a factory-approved, field-installed, UL listed heater package is available from your equipment supplier. See unit rating plate for a list of factory-approved heaters. Heaters that are not factory approved could cause damage which would not be covered under the equipment warranty. If fan coil contains a factory-installed heater package, minimum circuit ampacity (MCA) and maximum fuse/breaker may be different than units with a same size field-installed accessory heater. The difference is not an error and is due to calculation differences per UL guidelines.

INSTALLATION

CHECK EQUIPMENT

Unpack unit and move to final location. Remove carton taking care not to damage unit. Inspect equipment for damage prior to installation. File claim with shipping company if shipment is damaged or incomplete.

Locate unit rating plate which contains proper installation information. Check rating plate to be sure unit matches job specifications.

MOUNT UNIT

Unit can stand or lie on floor, or hang from ceiling or wall. Allow space for wiring, piping, and servicing unit.

IMPORTANT: When unit is installed over a finished ceiling and/or living area, building codes may require a field-supplied secondary condensate pan to be installed under the entire unit. Some localities may allow as an alternative, the running of a separate, secondary condensate line. Consult local codes for additional restrictions or precautions.

NOTE: Nuisance sweating may occur if the unit is installed in a high humidity environment with low airflow.

UPFLOW INSTALLATION

If return air is to be ducted through a floor, set unit on floor over opening and use 1/8 to 1/4-in (3 to 6 mm) thick fireproof resilient gasket between duct, unit, and floor.

Side return is a field option on slope coil models. Cut opening per dimensions. (See Fig. 1.) A field-supplied bottom closure is required.

DOWNFLOW INSTALLATION

In this application, field conversion of the evaporator is required using accessory downflow kit along with an accessory base kit. Use fireproof resilient gasket, 1/8 to 1/4-in (3 to 6 mm) thick, between duct, unit, and floor.

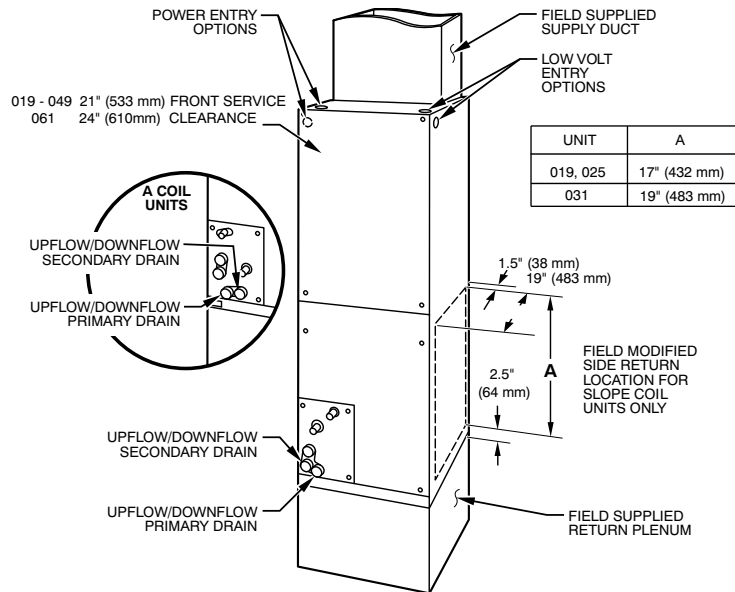

A09382

Fig. 1 – Slope Coil Unit in Upflow Application

! CAUTION

PRODUCT OR PROPERTY DAMAGE HAZARD

Failure to follow this warning caution may result in product or property damage.

The conversion of the fan coil to downflow requires special procedures for the condensate drains on both A-coil and Slope-coil units. The vertical drains have an overflow hole between the primary and secondary drain holes. This hole is plugged for all applications except downflow, and must be used for downflow. During conversion process, remove plastic cap covering vertical drains only and discard. Remove plug from overflow hole and discard. At completion of downflow installation, caulk around vertical pan fitting to door joint to retain low air leak performance of the unit.

NOTE: To convert units for downflow applications, refer to Installation Instructions supplied with kit for proper installation. For slope fan coils, use kit Part No. KFADC0201SLP. For A-coils, use kit Part No. KFADC0401ACL. Use fireproof resilient gasket, 1/8 to 1/4-in (3 to 6 mm) thick, between duct, unit, and floor.

NOTE: Gasket kit number KFAHD0101SLP is also required for all downflow applications to maintain low air leak/low sweat performance.

NOTE: Modular units can be disassembled and components moved separately to installation area for reassembly. This process accommodates small scuttle holes and limiting entrances to installation sites. (See Fig. 2.)

HORIZONTAL INSTALLATION

Units must not be installed with access panels facing up or down. All other units are factory built for horizontal left installation. (See Fig. 3 and 4.) When suspending unit from ceiling, dimples in casing indicate suitable location of screws for mounting metal support straps. (See Fig. 3.)

For horizontal applications having high return static and humid return air, the Water Management Kit, KFAHC0125AAA, may need to be used to assist in water management.

Horizontal Right Conversion of Units with Slope Coils

NOTE: Gasket kit number KFAHD0101SLP is required for horizontal slope coil conversion to maintain low air leak/low sweat performance.

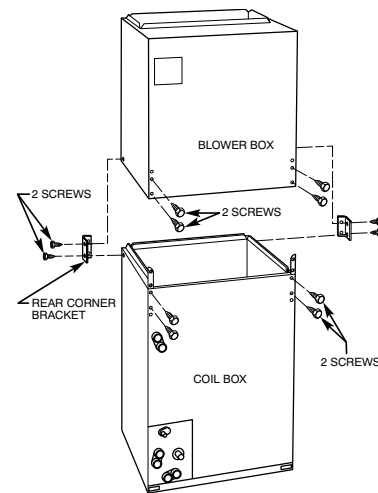

A95293

Fig. 2 – Modular Unit Assembly

! CAUTION

PROPERTY DAMAGE HAZARD

Failure to follow this caution may result in product or property damage. For optimum condensate drainage performance in horizontal installations, unit should be leveled along its length and width.

1. Remove blower and coil access panels and fitting panel. (See Fig. 5.)
2. Remove coil mounting screw securing coil assembly to right side casing flange.
3. Remove coil assembly.
4. Lay fan coil on its right side and reinstall coil assembly with condensate pan down (See Fig. 5.)
5. Attach coil to casing flange using previously removed coil mounting screw.
6. Make sure pan cap in fitting door is properly seated on fitting door to retain low air leak rating of the unit.
7. Add gaskets from kit - KFAHD.
8. Align holes with tubing connections and condensate pan connections. Reinstall access panels and fitting panel.

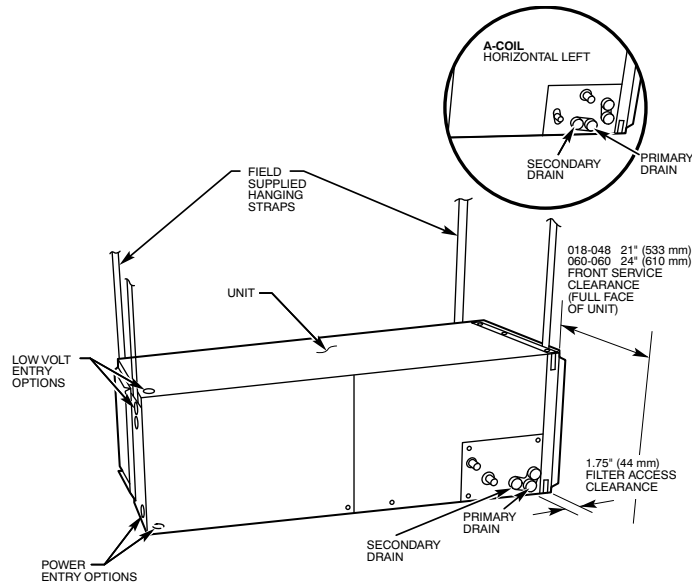

A07566

Fig. 3 – Slope Coil in Horizontal Left Application (Factory Configuration)

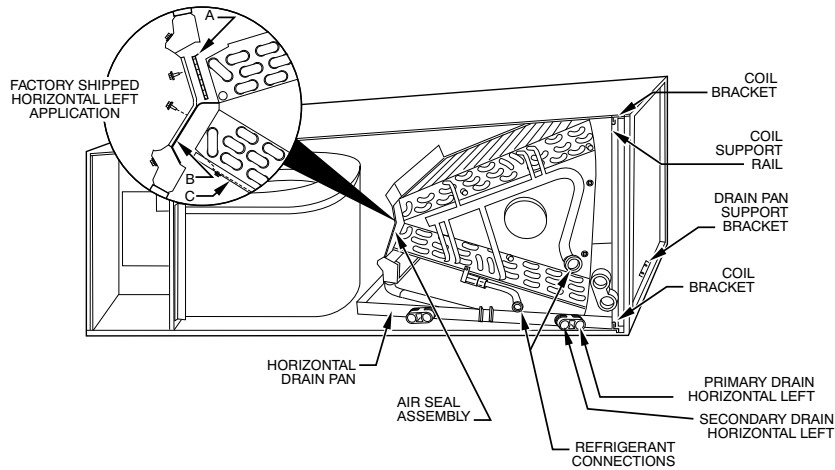

A00072A

Fig. 4 – A-Coil in Horizontal Left Application (Factory Configuration)

9. Make sure liquid and suction tube grommets are in place to prevent air leaks and cabinet sweating. Install grommets after brazing.

Horizontal Right Conversion of Units with A-Coils

1. Remove blower and coil access panels. (See Fig. 6.)
2. Remove metal clip securing fitting panel to condensate pan. Remove fitting panel.
3. Remove 2 snap-in clips securing A-coil in unit.
4. Slide coil and pan assembly out of unit.
5. Remove horizontal drain pan support bracket from coil support rail on left side of unit and reinstall on coil support rail on right side of unit. (See Fig. 7.)
6. Convert air seal assembly for horizontal right.
 - a. Remove air seal assembly from coil by removing 4 screws. (See Fig. 6)
 - b. Remove air splitter (B) from coil seal assembly by removing 3 screws. (See Fig. 6 inset)
 - c. Remove filler plate (A) and install air splitter (B) in place of filler plate.
 - d. Install filler plate (A) as shown in horizontal right application.
 - e. Remove condensate troughs (C) and install on opposite tube sheets.
 - f. Install hose onto plastic spout.

7. Install horizontal pan on right side of coil assembly.
8. Slide coil assembly into casing. Be sure coil bracket on each corner of vertical pan engages coil support rails.
9. Reinstall 2 snap-in clips to correctly position and secure coil assembly in unit. Be sure clip with large offset is used on right side of unit to secure horizontal pan.
10. Remove two oval fitting caps from left side of the coil, access panel, and fitting panel.
11. Remove insulation knockouts on right side of coil access panel.
12. Remove 2 oval coil access panel plugs and reinstall into holes on left side of coil access panel and fitting panel.
13. Install condensate pan fitting caps (from Step 10) in right side of coil door making sure that cap snaps and seats cleanly on back side of the coil door. Make sure no insulation interferes with seating of cap.
14. Reinstall access and fitting panels, aligning holes with tubing connections and condensate pan connections. Be sure to reinstall metal clip between fitting panel and vertical condensate pan.
15. Make sure liquid and suction tube grommets are in place to prevent air leaks and cabinet sweating.

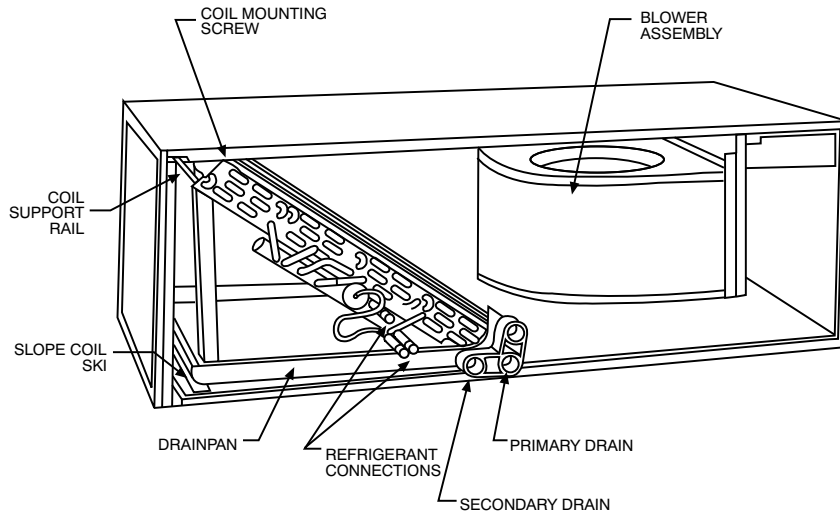

A03001

Fig. 5 – Conversion for Horizontal Right Applications - Slope Coil

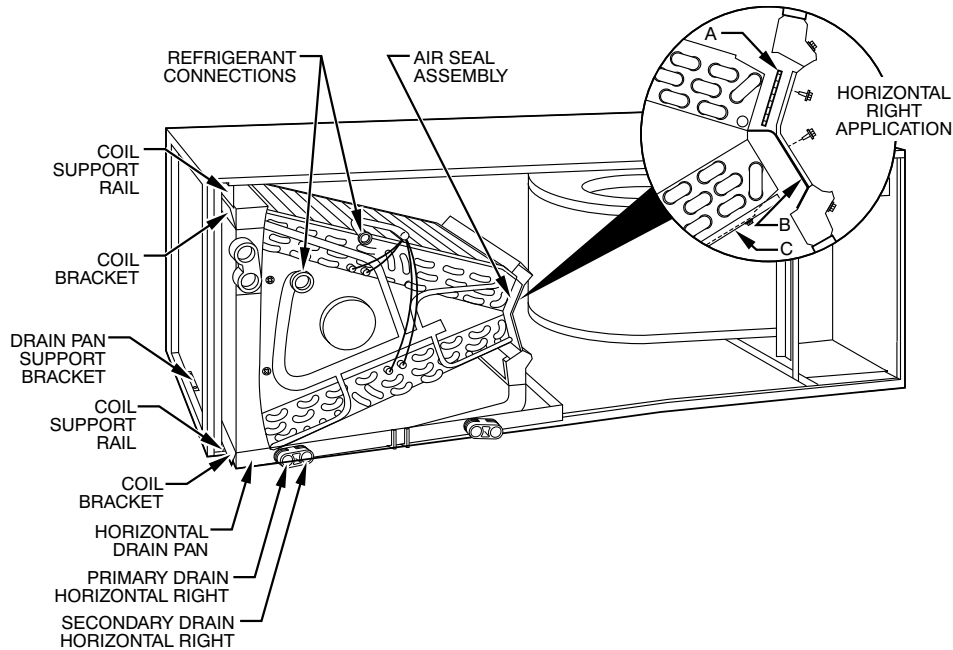

A00071A

Fig. 6 – Conversion for Horizontal Right Applications - A-Coil

MANUFACTURED HOUSING AND MOBILE HOME APPLICATIONS

1. Fan coil unit must be secured to the structure using field-supplied hardware.
2. Allow a minimum of 24 inches (610mm) clearance from access panels.
3. Recommended method of securing for typical applications:
 - a. If fan coil is away from wall, attach pipe strap to top of fan coil using No. 10 self tapping screws. Angle strap down and away from back of fan coil, remove all slack, and fasten to wall stud of structure using 5/16" lag screws. Typically both sides of the fan coil.
 - b. If fan coil is against wall, secure fan coil to wall stud using 1/8" (3mm) wide right-angle brackets. Attach brackets to fan coil using No. 10 self tapping screws and to wall stud using 5/16" lag screws (refer to Fig. 8).

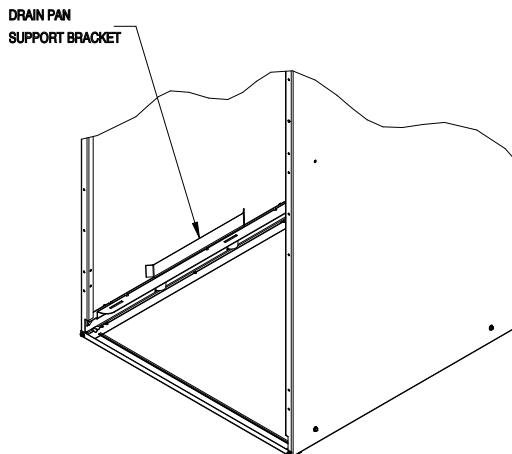

Fig. 7 – Drain Pan Support Bracket

A07571

AIR DUCTS

Connect supply-air duct over the outside of 3/4-in (19 mm) flanges provided on supply-air opening. Secure duct to flange, using proper fasteners for type of duct used, and seal duct-to-unit joint. If return-air flanges are required, install factory-authorized accessory kit.

Use flexible connectors between ductwork and unit to prevent transmission of vibration. When electric heater is installed, use heat-resistant material for flexible connector between ductwork and unit at discharge connection. Ductwork passing through unconditioned space must be insulated and covered with vapor barrier.

Units equipped with 20-30kW electric heaters require a 1-in (25 mm) clearance to combustible materials for the first 36-in (914 mm) of supply duct.

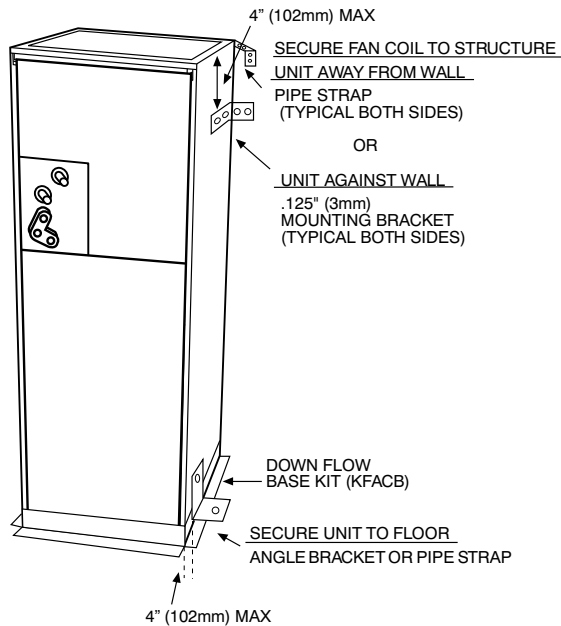

Fig. 8 – Mobile Home or Manufactured Housing Applications

A07567

DUCT WORK ACOUSTICAL TREATMENT

Metal duct systems that do not have a 90 degree elbow and 10 feet of main duct before first branch takeoff may require internal acoustical insulation lining. As an alternative, fibrous duct work may be used if constructed and installed in accordance with the latest edition of SMACNA construction standard on fibrous glass ducts. Both acoustical lining and fibrous duct work shall comply with National Fire Protection Association as tested by UL Standard 181 for Class 1 air ducts.

ELECTRICAL CONNECTIONS

All products from the factory protect the low voltage circuit with a 5 amp automotive type fuse inline on the wire harness. Speed selections are made at the fan motor by selecting taps 1, 2 or 3 with the blue wire (see section E). The motor is pre-programmed with the time delay circuit on some of the speed taps (see section E for clarification).

When a factory-approved accessory control package has been installed, check all factory wiring per unit wiring diagram and inspect factory wiring connections to be sure none were loosened in transit or installation. If a different control package is required, see unit rating plate.

Before proceeding with electrical connections, make certain that supply voltage, frequency, phase, and ampacity are as specified on the unit rating plate. See unit wiring label for proper field high- and low-voltage wiring. Make all electrical connections in accordance with the NEC and any local codes or ordinances that may apply. Use copper wire only.

! WARNING

ELECTRICAL SHOCK OR UNIT DAMAGE HAZARD

Failure to follow this warning could result in personal injury, death, and/or unit damage.

If a disconnect switch is to be mounted on unit, select a location where drill and fasteners will not contact electrical or refrigeration components.

The unit must have a separate branch electric circuit with a field-supplied disconnect switch located within sight from, and readily accessible from, the unit.

On units with a factory-installed disconnect with pull-out removed, service and maintenance can be safely performed on only the load side of the control package.

! WARNING

ELECTRICAL SHOCK HAZARD

Failure to follow this warning could result in personal injury or death.

Field wires on the line side of the disconnect found in the fan coil unit remain live, even when the pull-out is removed. Service and maintenance to incoming wiring cannot be performed until the main disconnect switch (remote to the unit) is turned off. Lock out and tag switch with a suitable warning label.

LINE VOLTAGE CONNECTIONS

If unit contains an accessory electric heater, remove and discard power plug from fan coil and connect male plug from heater to female plug from unit wiring harness. (See Electric Heater Installation Instructions.)

For units without electric heat:

1. Connect 208/230V power leads from field disconnect to yellow and black stripped leads.
2. Connect ground wire to unit ground lug.

NOTE: Units installed without electric heat should have a field-supplied sheet metal block-off plate covering the heater opening. This will reduce air leakage and formation of exterior condensation.

24V CONTROL SYSTEM

Connection To Unit

Wire low voltage in accordance with wiring label on the blower. (See Fig. 9 through 14.) Use no. 18 AWG color-coded, insulated (35_C minimum) wire to make the low-voltage connections between the thermostat, the unit, and the outdoor equipment. If the thermostat is located more than 100-ft (30 m) from the unit (as measured along the low-voltage wire), use no. 16 AWG color-coded, insulated (35_C minimum) wire. All wiring must be NEC Class 1 and must be separated from incoming power leads.

Refer to outdoor unit wiring instructions for any additional wiring procedure recommendations.

MANUFACTURED HOUSING

In manufactured housing applications, the Code of Federal Regulations, Title 24, Chapter XX, Part 3280.714 requires that supplemental electric heat be locked out at outdoor temperatures above 40_F (4_C), except for a heat pump defrost cycle. Refer to Fig. 14 for typical low voltage wiring with outdoor thermostat.

TRANSFORMER INFORMATION

Transformer is factory wired for 230V operation. For 208V applications, disconnect the black wire from the 230V terminal on transformer and connect it to the 208V terminal (refer to Fig. 15).

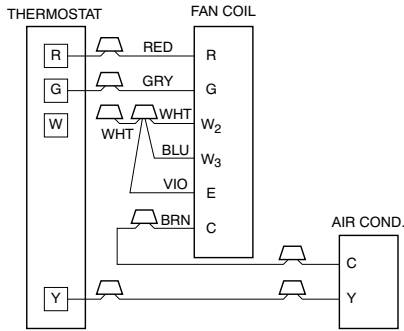

Fig. 9 – Wiring Layout Air Conditioning Unit (Cooling Only)

A09383

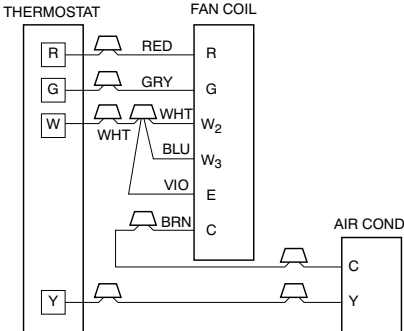

Fig. 10 – Wiring Layout Air Conditioning Unit (Cooling and 1-Stage Heat)

A09384

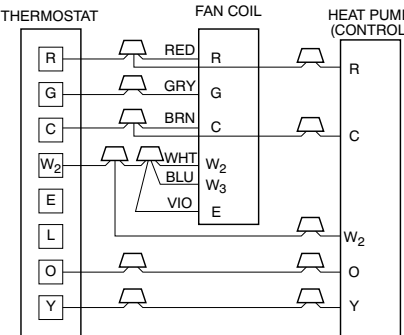

Fig. 11 – Wiring Layout Heat Pump Unit (Cooling and 2-Stage Heat with No Outdoor Thermostat)

A09385

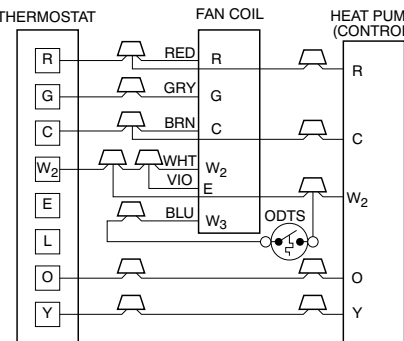

Fig. 12 – Wiring Layout Heat Pump Unit (Cooling and 2-Stage Heat with 1 Outdoor Thermostat)

A09386

HEATER STAGING

The controls are factory circuited for single-stage operation. For 2-stage operation, use outdoor thermostat kit Part No. KHAOT0301FST, and for 3-stage use both kits Part No. KHAOT0201SEC and KHAOT0301FST.

When 2 stages are desired, cut W3 at the W2 wire nut, strip and reconnect per the thermostat kit instruction. (See Fig. 13.) When 3 stages are desired, cut the W2 wire nut off and discard. Strip W2, W3, and E and reconnect per thermostat kit instructions. (See Fig. 13.)

NOTE: When 3 stages are used or anytime the E terminal is not tied to W2, the emergency heat relay, part of outdoor kit Part No. KHAOT0201SEC must be used.

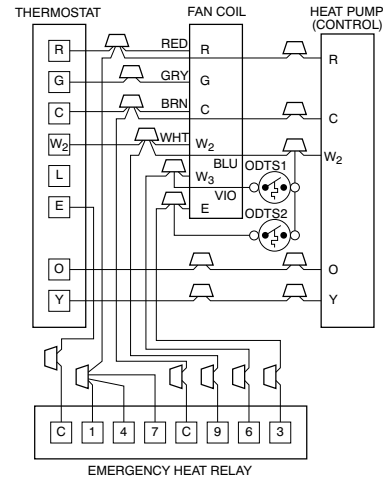

Fig. 13 – Wiring Layout Heat Pump Unit (Cooling and 2-Stage Heat with 2 Outdoor Thermostats)

A09387

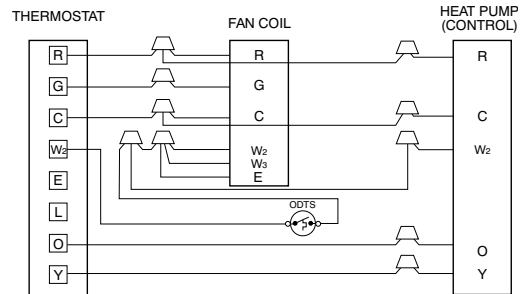

Fig. 14 – Wiring Layout Heat Pump Unit (Cooling and 2-Stage Heat for Manufactured Housing)

A09388

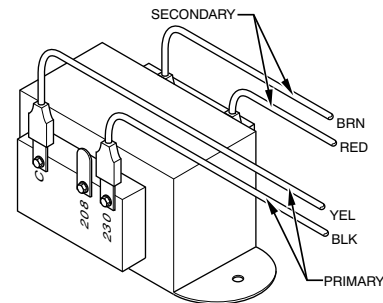

Fig. 15 – Transformer Connections

A05182

! CAUTION

PROPERTY DAMAGE HAZARD

Failure to follow this caution may result in product or property damage. If W2, W3, and E on any 3 stage heater (18, 20, 24, or 30kW) are individually connected - as with outdoor thermostats or any other situation - emergency heat relay must be used. This relay is in kit Part No. KHOT0201SEC and is used normally with kit Part No. KHAOT0301FST.

GROUND CONNECTIONS

NOTE: Use UL listed conduit and conduit connectors for connecting supply wire(s) to unit to obtain proper grounding. Grounding may also be accomplished by using grounding lugs provided in control box.

! WARNING

ELECTRICAL SHOCK HAZARD

Failure to establish uninterrupted or unbroken ground could result in personal injury and/or death.

According to NEC, NFPA 70, and local codes, the cabinet must have an uninterrupted or unbroken ground to minimize personal injury if an electrical fault should occur. The ground may consist of electrical wire or metal conduit when installed in accordance with existing electrical codes. If conduit connection uses reducing washers, a separate ground wire must be used.

MINIMUM CFM AND MOTOR SPEED SELECTION

The fan speed selection is done at the motor connector. Units with or without electric heaters require a minimum CFM. Refer to the unit wiring label to ensure that the fan speed selected is not lower than the minimum fan speed indicated.

Table 1 – Motor Speed Selection

Tap 1	Low	90 sec off delay
Tap 2	Medium	90 sec off delay
Tap 3	High	90 sec off delay
Tap 4	Electric heat †	0 sec off delay
Tap 5	Max ‡	0 sec off delay

† electric heat airflow is same CFM as Tap 3, except 0 sec off delay

‡ high static applications, see airflow tables for max airflow

To change motor speeds disconnect the BLUE fan lead from motor connector terminal #2 (factory default position) and move to desired speed-tap; 1, 2, 3, or 5.

Speed-taps 1, 2, and 3 have a 90 second blower off time delay pre-programmed into the motor. Speed-tap 4 is used for electric heat only (with 0 second blower time delay) and the WHITE wire should remain on tap 4. Speed-tap 5 is used for high static applications, but has a 0 second blower time delay pre-programmed into the motor. See Airflow Performance tables for actual CFM. Also, see Fig. 16 for motor speed selection location.

NOTE: In low static applications, lower motor speed tap should be used to reduce possibility of water being blown off coil.

! CAUTION

PRODUCT DAMAGE HAZARD

Failure to follow this caution may result in product or property damage. A brazing shield **MUST** be used when tubing sets are being brazed to the unit connections to prevent damage to the unit surface and condensate pan fitting caps.

REFRIGERANT TUBING CONNECTION AND EVACUATION

Use accessory tubing package or field-supplied tubing of refrigerant grade. Suction tube must be insulated. Do not use damaged, dirty, or contaminated tubing because it may plug refrigerant flow-control device. **ALWAYS** evacuate the coil and field-supplied tubing to 500 microns before opening outdoor unit service valves.

Units have sweat suction and liquid tube connections. Make suction tube connection first.

1. Cut tubing to correct length.

2. Insert tube into sweat connection on unit until it bottoms.
3. Braze connection using silver bearing or non-silver bearing brazing materials. Do not use solder (materials which melt below 800_F / 427_C). Consult local code requirements.

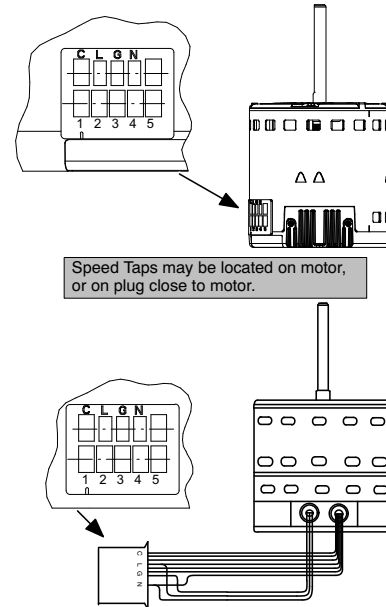

Fig. 16 – Motor Speed Selection

A11048

4. Evacuate coil and tubing system to 500 microns using deep vacuum method.

! CAUTION

PRODUCT DAMAGE HAZARD

Failure to follow this caution may result in product or property damage. Wrap a wet cloth around rear of fitting to prevent damage to TXV and factory-made joints.

REFRIGERANT FLOW-CONTROL DEVICE

The FX4D is equipped with PuronR refrigerant TXV. Use outdoor units designed for PuronR refrigerant only.

! CAUTION

PRODUCT OPERATION HAZARD

Failure to follow this caution may result in improper product operation. If using a TXV in conjunction with a single-phase reciprocating compressor, a compressor start capacitor and relay are required. Consult outdoor unit pre-sale literature for start assist kit part number.

CONDENSATE DRAINS

To connect drains, the cap openings must be removed. Use a knife to start the opening near the tab and using pliers, pull the tab to remove the disk. Clean the edge of the opening if necessary and install the condensate line. Finally caulk around the lines where they exit the fitting to retain the low leak rating of the unit.

Units are equipped with primary and secondary 3/4-in. FPT drain connections. For proper condensate line installations see Fig. 1, 3, 4, 5 and 6. To prevent property damage and achieve optimum drainage performance, BOTH primary and secondary drain lines should be installed and include properly-sized condensate traps. (See Fig. 17 and 19.) Factory-approved condensate traps are available. It is recommended that PVC fittings be used on the plastic condensate pan. Finger-tighten plus 1-1/2 turns. Do not over-tighten. Use pipe dope.

NOTE: When connecting condensate drain lines, avoid blocking filter access panel, thus preventing filter removal. After connection, prime both primary and secondary condensate traps.

! WARNING

PRODUCT OR PROPERTY DAMAGE HAZARD

Failure to follow this warning caution may result in product or property damage.

The conversion of the fan coil to downflow requires special procedures for the condensate drains on both A-coil and Slope-coil units. The vertical drains have an overflow hole between the primary and secondary drain holes. This hole is plugged for all applications except downflow, and must be used for downflow. During conversion process, remove plastic cap covering vertical drains only and discard. Remove plug from overflow hole and discard. At completion of downflow installation, caulk around vertical pan fitting to door joint to retain low air leak performance of the unit.

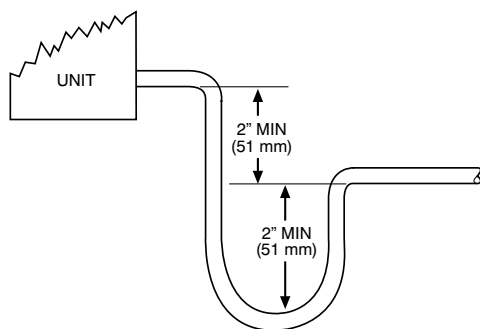
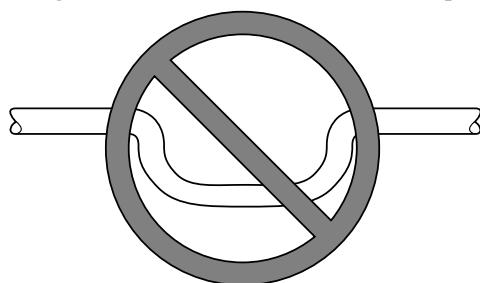

Fig. 17 – Recommended Condensate Trap

A03002



DO NOT USE SHALLOW RUNNING TRAPS!

Fig. 18 – Insufficient Condensate Trap

A03013

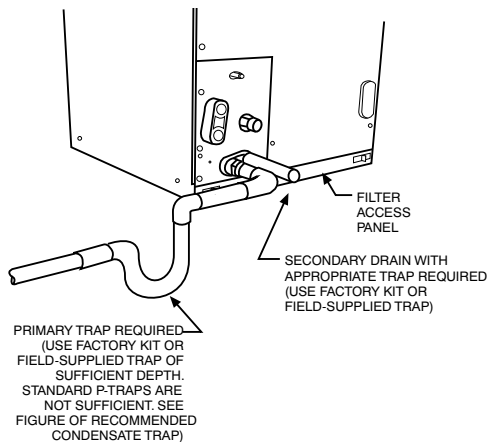

Fig. 19 – Condensate Drain

A03003

NOTE: If unit is located in or above a living space where damage may result from condensate overflow, a field-supplied, external condensate pan should be installed underneath the entire unit, and a secondary condensate line (with appropriate trap) should be run from the unit into the pan. Any condensate in this external condensate pan should be drained to a noticeable place. As an alternative to using an external condensate pan, some localities may allow the use of a separate 3/4-in (19 mm) condensate line (with appropriate trap) to a place where the condensate will be noticeable. The owner of the structure must be informed that when condensate flows from the secondary drain or external condensate pan, the unit requires servicing or water damage will occur.

Install traps in the condensate lines as close to the coil as possible. (See Fig. 19.) Make sure that the outlet of each trap is below its connection to the condensate pan to prevent condensate from overflowing the drain pan. Prime all traps, test for leaks, and insulate traps if located above a living area. Condensate drain lines should be pitched downward at a minimum slope of 1-in (25 mm) for every 10-ft (3 m) of length. Consult local codes for additional restrictions or precautions.

! CAUTION

PRODUCT DAMAGE HAZARD

Failure to follow this caution may result in product or property damage. Use only full size P-traps in the condensate line (refer to Fig. 17). Shallow running traps are inadequate and DO NOT allow proper condensate drainage (refer to Fig. 18).

ACCESSORIES

HUMIDIFIER

Connect humidifier and humidistat to fan coil unit as shown in Fig. 20 and Fig. 21. The cooling lockout relay is optional.

SEQUENCE OF OPERATION

CONTINUOUS FAN

Thermostat closes R to G. G energizes fan relay on PCB which completes circuit to indoor blower motor. When G is de-energized, there is a 90 second delay before relay opens.

NOTE: Speed taps 1, 2 and 3 have a 90 second blower off delay. Speed taps 4 and 5 have 0 second blower off delay.

COOLING MODE

Thermostat energizes R to G, R to Y, and R to O (heat pump only). G energizes fan relay on PCB which completes circuit to indoor blower motor. When G is de-energized, there is a 90 second delay before fan relay opens.

NOTE: Speed taps 1, 2 and 3 have a 90 second blower off delay. Speed taps 4 and 5 have 0 second blower off delay.

HEAT PUMP HEATING WITH AUXILIARY ELECTRIC HEAT

Thermostat energizes R to G, R to Y, and R to W. G energizes fan relay on PCB which completes circuit to indoor blower motor. W energizes electric heat relay(s) which completes circuit to heater element(s). When W is de-energized, electric heat relay(s) open, turning off heater elements. When G is de-energized there is a 90 second delay before fan relay opens.

NOTE: Speed taps 1, 2 and 3 have a 90 second blower off delay. Speed taps 4 and 5 have 0 second blower off delay.

ELECTRIC HEAT OR EMERGENCY HEAT MODE

Thermostat closes R to W. W energizes electric heat relay(s) which completes circuit to heater element(s). Blower motor is energized through normally closed contacts on fan relay. When W is de-energized, electric heat relay(s) opens.

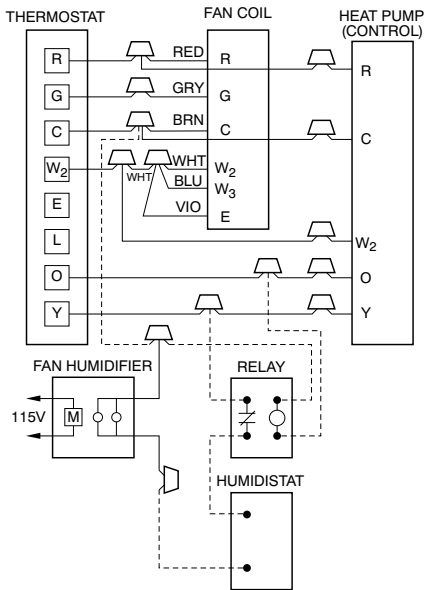

Fig. 20 – Wiring Layout of Humidifier to Heat Pump

A09391

START-UP PROCEDURES

Refer to outdoor unit Installation Instructions for system start-up instructions and refrigerant charging method details.

CAUTION

PRODUCT DAMAGE HAZARD

Failure to follow this caution may result in poor unit performance and/or product damage.

Never operate unit without a filter. Factory authorized filter kits may be used when locating the filter inside the unit. For those applications where access to an internal filter is impractical, a field-supplied filter must be installed in the return air duct system.

Table 2 – Air Delivery Performance Correction Component Pressure Drop (in. wc) at Indicated Airflow (Dry to Wet Coil)

FX Size	CFM															
	500	600	700	800	900	1000	1100	1200	1300	1400	1500	1600	1700	1800	1900	2000
019	0.034	0.049	0.063	--	--	--	--	--	--	--	--	--	--	--	--	--
025	0.016	0.027	0.038	0.049	0.059	--	--	--	--	--	--	--	--	--	--	--
031	--	--	--	0.049	0.059	0.070	0.080	--	--	--	--	--	--	--	--	--
037	--	--	--	--	--	0.055	0.064	0.073	0.081	--	--	--	--	--	--	--
043	--	--	--	--	--	--	--	0.049	0.056	0.063	0.070	--	--	--	--	--
049	--	--	--	--	--	--	--	--	--	0.038	0.043	0.049	0.054	0.059	--	--
061	--	--	--	--	--	--	--	--	--	--	--	0.027	0.031	0.035	0.039	0.043

Table 3 – Factory-Installed Filter Static Pressure Drop (in. wc)

FX SIZE	CFM								
	400	600	800	1000	1200	1400	1600	1800	2000
019	0.020	0.044	0.075	-	-	-	-	-	-
025 - 031	-	0.022	0.048	0.072	0.100	-	-	-	-
037-049	-	-	-	0.051	0.070	0.092	0.120	0.152	-
061	-	-	-	-	-	-	0.086	0.105	0.130

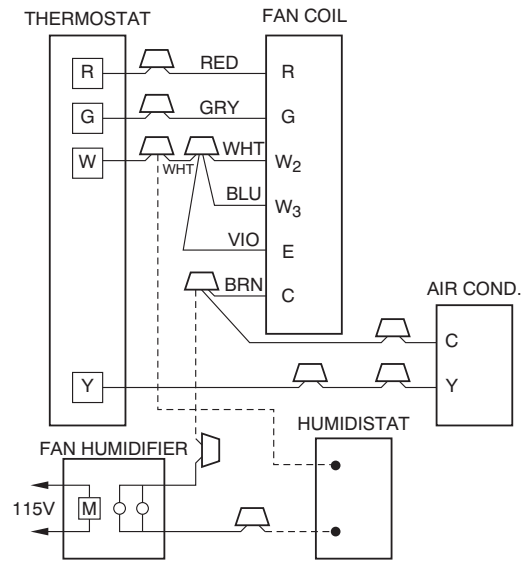

Fig. 21 – Wiring Layout of Humidifier to Fan Coil with Electric Heat

A09389

CARE AND MAINTENANCE

To continue high performance and minimize possible equipment failure, it is essential that periodic maintenance be performed on this equipment. Consult your local dealer as to the proper frequency of maintenance contract.

The ability to properly perform maintenance on this equipment requires certain mechanical skills and tools. If you do not possess these, contact your dealer for maintenance. The only consumer service recommended or required is filter replacement or cleaning on a monthly basis.

Table 4 – Electric Heater Static Pressure Drop (in. wc)

FX 019 - 037			FX 043 - 061		
HEATER ELEMENTS	KW	EXTERNAL STATIC PRESSURE CORRECTION	HEATER ELEMENTS	KW	EXTERNAL STATIC PRESSURE CORRECTION
0	0	+ .02	0	0	+ .04
1	3, 5	+ .01	2	8, 10	+ .02
2	8, 10	0	3	9, 15	0
3	9, 15	- .02	4	20	- .02
4	20	- .04	6	18, 24, 30	- .10

Table 5 – Airflow Performance (CFM) in Cooling Mode

Model & Size	Blower Speed	EXTERNAL STATIC (in. wc)					
		0.10	0.20	0.30	0.40	0.50	0.60
FX4D 019	Tap 5	776	745	696	660	609	572
	Tap 4	683	644	589	548	494	461
	Tap 3	683	644	589	548	494	461
	Tap 2	631	563	500	443	409	361
	Tap 1	625	524	457	417	367	319
FX4D 025	Tap 5	956	920	891	851	816	780
	Tap 4	825	795	757	722	674	634
	Tap 3	825	795	757	722	674	634
	Tap 2	726	695	635	598	543	509
	Tap 1	631	563	500	443	409	361
FX4D 031	Tap 5	1189	1151	1104	1050	1003	959
	Tap 4	1041	998	944	886	837	772
	Tap 3	1041	998	944	886	837	772
	Tap 2	924	876	817	752	704	660
	Tap 1	779	693	628	571	526	476
FX4D 037	Tap 5	1363	1332	1294	1253	1207	1157
	Tap 4	1237	1206	1160	1121	1070	1013
	Tap 3	1237	1206	1160	1121	1070	1013
	Tap 2	1095	1058	1007	951	888	824
	Tap 1	1014	885	773	673	609	549
FX4D 043	Tap 5	1519	1490	1454	1419	1379	1332
	Tap 4	1437	1403	1366	1333	1294	1245
	Tap 3	1437	1403	1366	1333	1294	1245
	Tap 2	1257	1226	1191	1141	1090	1033
	Tap 1	1237	1206	1160	1121	1070	1013
FX4D 049	Tap 5	1757	1725	1693	1653	1614	1576
	Tap 4	1664	1626	1593	1552	1517	1477
	Tap 3	1664	1626	1593	1552	1517	1477
	Tap 2	1459	1420	1379	1336	1298	1259
	Tap 1	1301	1241	1195	1150	1102	1039
FX4D 061	Tap 5	2030	1995	1961	1927	1888	1842
	Tap 4	1811	1775	1740	1703	1664	1613
	Tap 3	1811	1775	1740	1703	1664	1613
	Tap 2	1665	1632	1593	1556	1507	1453
	Tap 1	1462	1418	1371	1327	1278	1228

■ - Shading - Airflow outside 450 cfm/ton.

NOTES:

1. Airflow based upon dry coil at 230v with factory approved filter and electric heater (2 element heater sizes 019 through 037, 3 element heater sizes 043 through 061).
2. Airflow at 208 volts is approximately the same as 230 volts because the multi-tap ECM motor is a constant torque motor. The torque doesn't drop off at the speeds the motor operates.
3. To avoid potential for condensate blowing out of drain pan prior to making drain trap:
Return static pressure must be less than 0.40 in. wc.
Horizontal applications of 043 - 061 sizes must have supply static greater than 0.20 in. wc.
4. Airflow above 400 cfm/ton on 049 - 061 size could result in condensate blowing off coil or splashing out of drain pan.