

569J*08G/H

**AIR-COOLED CONDENSING UNITS, 60 Hz,
SINGLE CIRCUIT, 2-STAGE WITH DIGITAL SCROLL COMPRESSOR
AND PURON® (R-410A) REFRIGERANT - SIZE 08**



Installation, Start-Up and Service Instructions

TABLE OF CONTENTS

SAFETY CONSIDERATIONS	2	ROUTINE SYSTEM MAINTENANCE	20
Rated Indoor Airflow (cfm)	3	Quarterly Inspection (and 30 days after initial start)	20
Matching 569J*08G/H Model to Evaporator Coil	6	Seasonal Maintenance	20
INSTALLATION	6-16	SERVICE	21 - 27
Jobsite Survey	6	Refrigeration System	21
Step 1 - Plan for Unit Location	6	Compressor Oil	21
Step 2 - Complete Pre-Installation Checks	6	Servicing Systems on Roofs with Synthetic Materials	21
Step 3 - Prepare Unit Mounting Support	6	Liquid Line Filter Drier	21
Step 4 - Rig and Mount the Unit	6	Filed Refrigerant Access Ports	21
Step 5 - Determine Refrigerant Line Sizes	7	Factory High-Flow Access Ports	21
Step 6 - Complete Refrigerant Piping Connections	8	Comfort Alert Diagnostic Module	22
Step 7 - Install Accessories	10	Compressor Protection	24
Step 8 - Complete Electrical Connections	10	Crankcase Heater	24
Step 9 - Wind Baffles for Low Ambient Controls	16	Low-Pressure Switch	24
PRE-START-UP	16	High-Pressure Switch	24
System Check	16	Outdoor Fans	24
Turn On Crankcase Heater	16	Lubrication	24
Preliminary Charge	16	Routine Cleaning of Round-Tube Plate Fin (RTPF) Coils	26
START-UP	16 - 19	Fastener Torque Values	27
Preliminary Checks	16	TROUBLESHOOTING	27 - 28
Start Unit	17	APPENDIX A	
OPERATING SEQUENCE	20	Air Conditioner & Heat Pump with Puron® —	
Base Unit Controls	20	Quick Reference Guide	29
Indoor (Supply) Fan	20	APPENDIX B	
Cooling, Unit Without Economizer	20	Wiring Diagram List	29
Cooling, Unit with Economizer	20	APPENDIX C	
Heating	20	Low Ambient Option — Factory Installed	29
		START-UP CHECKLIST	35 - 36

SAFETY CONSIDERATIONS

Improper installation, adjustment, alteration, service, maintenance, or use can cause explosion, fire, electrical shock or other conditions which may cause personal injury or property damage. Consult a qualified installer, service agency, or your distributor or branch for information or assistance. The qualified installer or agency must use factory-authorized kits or accessories when modifying this product. Refer to the individual instructions package

Follow all safety codes. Wear safety glasses and work gloves. Use quenching cloths for brazing operations and have a fire extinguisher available. Read these instructions thoroughly and follow all warnings or cautions attached to the unit. Consult local building codes and appropriate national electrical codes (in USA, ANSI/NFPA70, National Electrical Code (NEC); in Canada, CSA C22.1) for special requirements.

It is important to recognize safety information. This is the safety-alert symbol . When you see this symbol on the unit and in instructions or manuals, be alert to the potential for personal injury.

569J*08G/H

WARNING

ELECTRICAL SHOCK HAZARD

Failure to follow this warning could cause in personal injury or death.

Before performing service or maintenance operations on unit, always turn off main power switch to unit and install lockout tag. Unit may have more than one power switch.

WARNING

UNIT OPERATION AND SAFETY HAZARD

Failure to follow this warning could cause in personal injury, death and/or equipment damage.

Puron[®] (R-410A) refrigerant systems operate at higher pressures than standard R-22 systems. Do not use R-22 service equipment or components on Puron refrigerant equipment.

WARNING

PERSONAL INJURY AND ENVIRONMENTAL HAZARD

Failure to follow this warning could cause in personal injury or death.

Relieve pressure and recover all refrigerant before system repair or final unit disposal.

Wear safety glasses and gloves when handling refrigerants. Keep torches and other ignition sources away from refrigerants and oils.

CAUTION

CUT HAZARD

Failure to follow this caution may result in personal injury.

Sheet metal parts may have sharp edges or burrs. Use care and wear appropriate protective clothing, safety glasses and gloves when handling parts and servicing 569J units.

Rated Indoor Airflow (cfm)

The table to the right lists the rated indoor airflow used for the AHRI efficiency rating for the units covered in this document.

Model Number	Full Load Airflow (cfm)
569J*08G/H – 524J*08A	3000

Position	1	2	3	4	5	6	7	8	9	10	11	12	13	14	15	16	17
Example	5	6	9	J	P	0	8	G	0	0	0	A	0	0	A	0	A

<p>Model Type 569J = Bryant Condensing Unit Puron® R-410A Refrigerant</p>	<p>Packaging A = Standard B = LTL</p>
<p>Voltage E = 460/3/60 P = 208/ 230/3/60 T = 575/3/60</p>	<p>Base Unit Controls 0 = Electro-Mechanical Controls</p>
<p>Nominal Tonnage 08 = 7.5 Tons</p>	<p>Electrical Options A = None C = Non-Fused Disconnect</p>
<p>Refrigerant Circuit G = Single Circuit, Dual Stage H = Single Circuit, Dual Stage w/ Low Ambient Controller</p>	<p>Service Options 0 = None 1 = Unpowered Convenience Outlet 2 = Powered Convenience Outlet</p>
<p>Not Used 0 = Not Used</p>	<p>Not Used 0 = Not Used</p>
<p>Not Used 0 = Not Used</p>	<p>Coil Options (RTPF) A = Cu/Al B = Precoat (Cu/Al) C = E-Coat (Cu/Al) E = Cu/Cu M = Cu/Al with Louvered Hail Guard N = Precoat (Cu/Al) with Louvered Hail Guard P = E-Coat (Cu/Al) with Louvered Hail Guard R = Cu/Cu with Louvered Hail Guard</p>
<p>Not Used 0 = Not Used</p>	

569J*08G/H

Fig. 1 - Model Number Nomenclature

C14311

NOTES:

1. MINIMUM CLEARANCE (LOCAL CODES OR JURISDICTION MAY PREVAIL):
 - A. BOTTOM TO COMBUSTIBLE SURFACES: 0 INCHES.
 - B. OUTDOOR COIL, FOR PROPER AIR FLOW: 36 INCHES ONE SIDE, 12 INCHES THE OTHER, THE SIDE GETTING THE GREATER CLEARANCE IS OPTIONAL.
 - C. OVERHEAD: 60 INCHES, TO ASSURE PROPER OUTDOOR FAN OPERATION.
 - D. BETWEEN UNITS: CONTROL BOX SIDE, 42 INCHES PER NEC.
 - E. BETWEEN UNIT AND UNGROUNDED SURFACES: CONTROL BOX SIDE: 36 INCHES PER NEC.
 - F. BETWEEN UNIT AND BLOCK OR CONCRETE WALLS AND OTHER GROUNDED SURFACES: CONTROL BOX SIDE, 42 INCHES PER NEC.
2. WITH EXCEPTION OF THE CLEARANCE FOR THE OUTDOOR COIL AS STATED IN NOTE 1B, A REMOVABLE FENCE OR BARRICADE REQUIRES NO CLEARANCE.
3. UNITS MAY BE INSTALLED ON COMBUSTIBLE FLOORS MADE FROM WOOD OR CLASS A, B OR C ROOF COVERING MATERIAL.

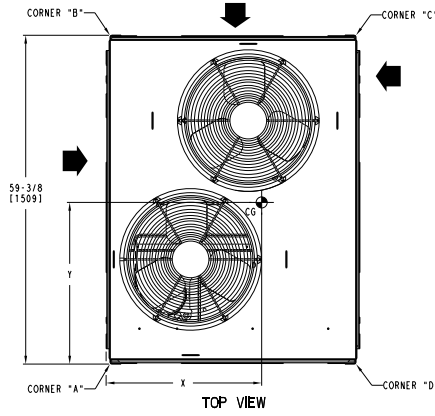
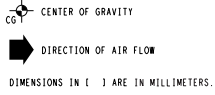

SERVICE VALVE CONNECTIONS			QTY
UNIT	SUCTION	LIQUID	
38AUZ08	1-1/8 [28.6]	1/2 [12.7]	1

569J*08G/H

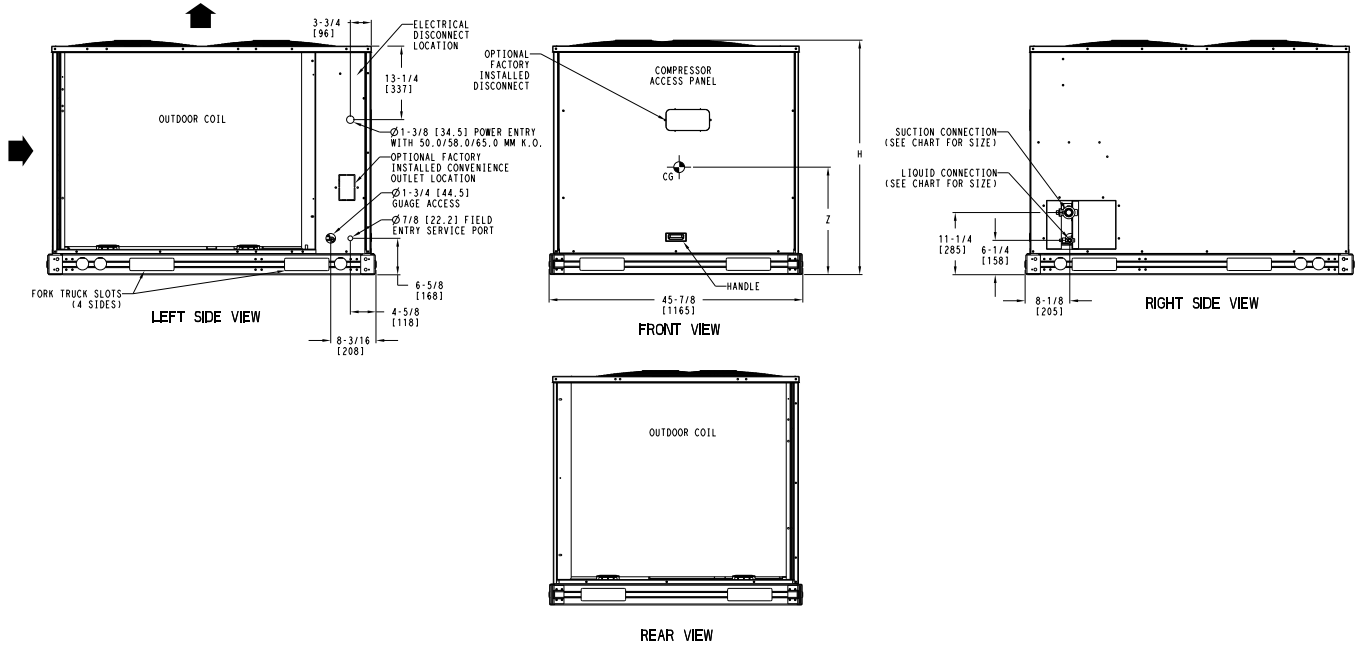

C14298

UNIT	STD. UNIT WT.		CORNER A		CORNER B		CORNER C		CORNER D		CENTER OF GRAVITY			UNIT HEIGHT
	lbs.	kg.	lbs.	kg.	lbs.	kg.	lbs.	kg.	lbs.	kg.	X	Y	Z	H
569J*08G/H	430	195	142	64	96	44	76	34	111	50	18 [457]	24 [610]	21 [533]	42 ³ / ₈ [1076]

Fig. 2 - 569J*08G/H Unit Dimensions

Table 1 – Physical Data
569J*08G/H — 60 Hz English

NOMINAL CAPACITY (tons)	7.5
OPERATING WEIGHTS (lb)	
Round Tube/Plate Fin Coil (Cu/Al)	430
REFRIGERANT TYPE‡	R-410A
RTPF Operating Charge, Typical (lb)†	18.0
RTPF Shipping Charge (lb)	14.0
Metering Device	TXV
COMPRESSOR	
Qty...Type	1...Digital Scroll
Oil Charge (oz)	60
CONDENSER FANS	
Qty...Rpm	2...1100
Motor Hp	1/4
Diameter	22
Nominal Airflow (Cfm Total)	6000
Watts (Total)	610
RTPF CONDENSER COIL	
Material (Tube/Fin)	Cu / Al
Coil Type	RTPF
Rows/Fins per inch (FPI)	2 / 17
Face Area (sq ft total)	23.0
CONTROLS	
Pressurestat Settings (psig)	
High Cutout	630 ± 10
Cut-in	505 ± 20
Low Cutout	54 ± 3
Cut-in	117 ± 5
PIPING CONNECTIONS (in. ODS)	
Qty...Suction	1...1 1/8
Qty...Liquid	1...1/2

LEGEND

RTPF — Round Tube/Plate Fin
ODS — Outside Diameter Sweat (socket)

‡ Unit is factory-supplied with partial charge only.
† Typical operating charge with 25 ft of interconnecting piping.

Table 2 – Physical Data
569J*08G/H — 60 Hz SI

NOMINAL CAPACITY (kW)	26.4
OPERATING WEIGHTS (lb)	
Round Tube/Plate Fin Coil (Cu/Al)	195
REFRIGERANT TYPE‡	R-410A
RTPF Operating Charge, Typical (kg)†	8.2
RTPF Shipping Charge (kg)	6.4
Metering Device	TXV
COMPRESSOR	
Qty...Type	1...Digital Scroll
Oil Charge (liters)	1.8
CONDENSER FANS	
Qty...r/s	2...18
Motor Hp NEMA	1/4
Diameter (mm)	560
Nominal Airflow (L/s)	2832
Watts (Total)	610
RTPF CONDENSER COIL	
Material (Tube/Fin)	Cu / Al
Coil Type	RTPF
Rows/Fins per Meter (Fins/m)	2 / 670
Face Area (sq m total)	2.1
CONTROLS	
Pressurestat Settings (kPa)	
High Cutout	4347 ± 70
Cut-in	3482 ± 138
Low Cutout	372 ± 21
Cut-in	807 ± 34
PIPING CONNECTIONS (in. ODS)	
Qty...Suction	1...1 1/8
Qty...Liquid	1...1/2

LEGEND

RTPF — Round Tube/Plate Fin
NEMA — National Electrical Manufacturers Association
ODS — Outside Diameter Sweat (socket)

‡ Unit is factory-supplied with partial charge only.
† Typical operating charge with 25 ft of interconnecting piping.

569J*08G/H

Matching 569J*08G/H Model to Evaporator Coil

The Model 569J*08G/H are a single-circuit, two-stage unit design, requiring one set of refrigeration piping.

INSTALLATION

Jobsite Survey

Complete the following checks before installation.

1. Consult local building codes and the NEC (National Electrical Code) ANSI/NFPA 70 for special installation requirements.
2. Determine unit location (from project plans) or select unit location.
3. Check for possible overhead obstructions which may interfere with unit lifting or rigging.

Step 1 — Plan for Unit Location

The 569J units are designed and approved for outdoor installation only. Do not locate these units indoors. Do not add ducting to unit fan system.

Select a location for the unit and its support system (pad, rails or other) that provides for the minimum clearances required for safety. This includes the clearance to combustible surfaces, unit performance and service access below, around and above unit as specified in unit drawings. See Fig. 4.

NOTE: Local codes may require different clearances than specified in Fig. 4. It is the responsibility of installers to be knowledgeable in local codes and to modify the recommended clearances to satisfy local codes.

NOTE: Consider also the effect of adjacent units on airflow performance and control box safety clearance.

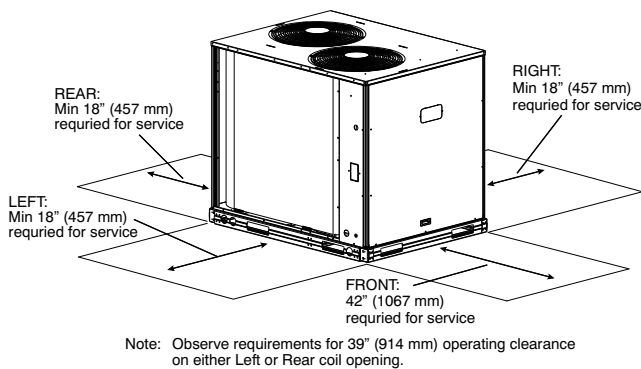

Fig. 3 - Service Clearance Dimensional Drawing

Do not install the outdoor unit in an area where fresh air supply to the outdoor coil may be restricted or when recirculation from the condenser fan discharge is possible. Do not locate the unit in a well or next to high walls.

Evaluate the path and required line length for interconnecting refrigeration piping, including suction riser requirements (outdoor unit above indoor unit), liquid line lift (outdoor unit below indoor unit) and hot gas

bypass line. Relocate sections to minimize the length of interconnecting tubing.

DO NOT BURY REFRIGERATION LINES.

Although unit is weatherproof, avoid locations that permit water from higher level runoff and overhangs to fall onto the unit.

Step 2 — Complete Pre-Installation Checks

Check Unit Electrical Characteristics: Confirm before installation of unit that voltage, amperage and circuit protection requirements listed on unit data plate agree with power supply provided.

Un-crate Unit: Remove unit packaging except for the top skid assembly, which should be left in place until after the unit is rigged into its final location.

Inspect Shipment: File a claim with shipping company if the shipment is damaged or incomplete.

Consider System Requirements:

- Consult local building codes and National Electrical Code (NEC, U.S.A.) for special installation requirements.
- Allow sufficient space for airflow clearance, wiring, refrigerant piping, and servicing unit. See Fig. 2 for unit dimensions and weight distribution data.
- Locate the unit so that the outdoor coil (condenser) airflow is unrestricted on all sides and above.
- The unit may be mounted on a level pad directly on the base channels or mounted on raised pads at support points. See Tables 1 and 2 for unit operating weights. See Fig. 2 for weight distribution based on recommended support points.

NOTE: If vibration isolators are required for a particular installation, use the data in Fig. 2 to make the proper selection.

Step 3 — Prepare Unit Mounting Support

Slab Mount —

Provide a level concrete slab that extends a minimum of 6 in. (150 mm) beyond unit cabinet. Install a gravel apron in front of condenser coil air inlet to prevent grass and foliage from obstructing airflow.

Step 4 — Rig and Mount the Unit

⚠ CAUTION

UNIT DAMAGE HAZARD

Failure to follow this caution may result in equipment damage.

All panels must be in place when rigging. Unit is not designed for handling by fork truck.

Rigging: These units are designed for overhead rigging. Refer to the rigging label for preferred rigging method.

Spreader bars are required. Use the wooden top skid, when rigging, to prevent rigging straps from damaging the unit. All panels must be in place when rigging. As further protection for coil faces, plywood sheets may be placed against the sides of the unit, behind cables. Run cables to a central suspension point so that the angle from the horizontal is not less than 45 degrees. Raise and set the unit down carefully.

If it is necessary to roll the unit into position, mount the unit on longitudinal rails, using a minimum of 3 rollers. Apply force to the rails, not the unit. If the unit is to be skidded into position, place it on a large pad and drag it by the pad. Do not apply any force to the unit.

Raise from above to lift the unit from the rails or pad when unit is in its final position.

After the unit is in position, remove all shipping materials and top crating.

Step 5 — Determine Refrigerant Line Sizes

Select the recommended line sizes for the 569J*08G/H unit from the Table 3.

Determine the linear length of interconnecting piping required between the outdoor unit and indoor unit (evaporator). Consider and identify also the arrangement of the tubing path (quantity and type of elbows in both lines), liquid line solenoid size, filter drier and any other refrigeration specialties located in the liquid line. Refer to the indoor unit installation instructions for additional details on refrigeration specialties devices.

Determine equivalent line length adjustments for path and components and add to linear line lengths. See Table 4, Equivalent Lengths for Common Fittings, for usual fitting types. Also identify adjustments for refrigeration specialties. Contact Bryant Applications Engineering for additional data and information on equivalent lengths.

Table 3 – 569J*08G/H Piping Recommendations

Model & Nominal capacity	Linear Line (ft)	0 – 25			25 – 50		50 – 75		75 – 100		100 – 125	
	Linear Line (m)	0 – 8			8 – 15		15 – 23		23 – 30		30 – 38	
	Equiv. Line (ft)	0 – 38			38 – 75		75 – 113		113 – 150		150 – 188	
	Equiv. Line (m)	0 – 12			12 – 23		23 – 34		34 – 46		46 – 57	
569J*08G/H	Liquid Line size	1/2"	1/2"	5/8"	1/2"	5/8"	1/2"	5/8"	1/2"	5/8"	1/2"	5/8"
	Liquid PD (°F)	0.6	1.3	0.3	1.9	0.5	2.5	0.7	3.2	0.9		
	Max Lift	25	50	50	75	75	100	100	97	97		
	Max Lift PD (°F)	2.7	5.4	4.5	8.1	6.7	10.8	9.0	11.2	8.9		
	Suction Line size	7/8"	7/8"	1 1/8"	7/8"	1 1/8"	1 1/8"		1 1/8"		1 3/8"	
	Suction Ln PD (°F)	1.5	3.1	0.8	4.6	1.2	1.6		2.1		0.7	
	Charge (lbs)	15.0	18.4	19.1	20.2	23.5	22.5	26.3	24.5	30.1		
	#/TR	1.96	2.40	2.49	2.63	3.07	2.93	3.43	3.20	3.93		

Legend:

Linear Line	Linear tubing length, feet
Equivalent Line	Equivalent tubing length, including effects of refrigeration specialties devices
Liquid Line size	Tubing size, inches OD.
Max Lift	Maximum liquid lift (indoor unit ABOVE outdoor unit only), at maximum permitted pressure drop
Max Lift PD (°F)	Pressure drop including Maximum liquid lift value.
Suction Line size	Tube size, inches OD
Suction PD (°F)	Suction Line Pressure Drop, saturated temperature, °F
(Cap Red)	Capacity Reduction caused by suction line PD greater than 2°F
Charge	Charge Quantity, lbs.
#/TR	Charge to unit capacity ratio, lbs per ton (at 45°F SST, 95°F ODA)

569J*08G/H

Table 4 – Equivalent Lengths for Common Fittings (ft)

Nominal Tube OD	Elbows				
	90° Std	90° Lrad	90° Street	45° Std	45° Street
3/8	1.3	0.8	2.2	0.6	1
1/2	1.4	0.9	2.3	0.7	1.1
5/8	1.6	1	2.5	0.8	1.3
3/4	1.8	1.2	2.9	0.9	1.5
7/8	2	1.4	3.2	0.9	1.6
1 1/8	2.6	1.7	4.1	1.3	2.1
1 3/8	3.3	2.3	5.6	1.7	3
1 5/8	4	2.6	6.3	2.1	3.4
2 1/8	5	3.3	8.2	2.6	4.5

Nominal Tube OD	Tees			
	Branch Flow	Straight-Thru		
		No Reduct	Reduce 25%	Reduce 50%
3/8	2.6	0.8	1.1	1.3
1/2	2.7	0.9	1.2	1.4
5/8	3	1	1.4	1.6
3/4	3.5	1.2	1.7	1.8
7/8	4	1.4	1.9	2
1 1/8	5	1.7	2.3	2.6
1 3/8	7	2.3	3.1	3.3
1 5/8	8	2.6	3.7	4
2 1/8	10	3.3	4.7	5

NOTE: Equivalent line lengths will vary based on tube diameter. Calculate equivalent line length for each pipe by adding equivalent length adjustments to linear lengths for each pipe.

Liquid Lift —

A liquid lift condition exists when the outdoor unit is located below the indoor (evaporator) unit and liquid flows vertically up in a portion of the liquid line. The vertical column of liquid reduces the available state point subcooling at the evaporator coil's thermal expansion valve. This effect reduces the length of liquid lift (feet of elevation) that a liquid line size can accommodate. Longer linear tube lengths will also reduce the amount of liquid lift possible.

Check Table 3 for maximum liquid lift capabilities for line sizes. Reselect the liquid line tube size if necessary. If maximum available tube size cannot provide the required lift distance on this installation, relocate the outdoor unit to reduce the equivalent line length or the lift requirement.

Suction Riser —

A suction riser condition exists when the outdoor unit is located above the indoor (evaporator) unit and suction vapor must flow vertically up to return to the compressor. Oil return is a concern when the suction tube size is too large to produce the minimum refrigerant velocity to ensure oil return at minimum load conditions.

Check Table 5 for maximum suction tube size for 569J*08G/H units at minimum load conditions. Consider

suction speed riser (reduced tube size for vertical segment only) (see Fig. 4) or double suction riser arrangement (see Fig. 5) if the planned suction tube size does not provide necessary minimum flowrates for this riser.

Table 5 – 569J Maximum Suction Pipe Size

Model:	Unit Size	Maximum Tube Size
569J***G/H	08	1 5/8

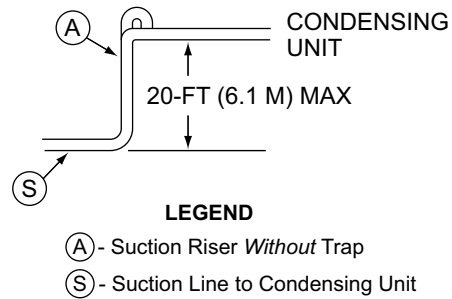

Fig. 4 - Suction Line Piping - Speed Riser

C12404

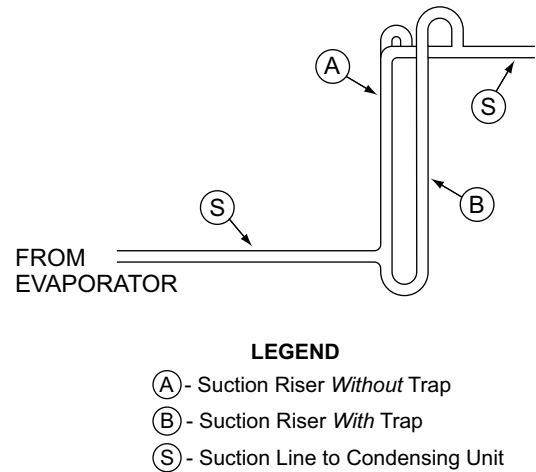

Fig. 5 - Suction Line Piping - Double Riser

C12405

Vertical Separation (outdoor unit above indoor unit) –

Vertical elevation difference of 200 ft (60 m) is permitted when the outdoor unit (569J) is located above the indoor unit.

Step 6 — Complete Refrigerant Piping Connections

IMPORTANT: Do not bury refrigerant piping underground.

IMPORTANT: A refrigerant receiver is not provided with the unit. Do not install a receiver.

Provide Safety Relief —

If local codes dictate an additional safety relief device, purchase locally and install locally. Installation will require the recovery of the factory shipping charge before the factory tubing can be cut and the supplemental relief device is installed.

Table 6 – Refrigerant Specialties Part Numbers

LIQUID LINE SIZE (in.)	LIQUID LINE SOLENOID VALVE (LLSV)	LLSV COIL	SIGHT GLASS	FILTER DRIER
1/2	EF680035	EF680037	KM680004	KH43LS085
5/8	EF680036	EF680037	KM680005	KH43LS087

Check 569J*08G/H Model with Evaporator Coil Connections —

Confirm before installation of unit that the evaporator coil connections are consistent with the 569J*08G/H.

Insulate Suction Lines —

Apply closed-cell tubular insulation to all suction lines between evaporator coil connection and 569J*08G/H unit’s suction service valve.

Refer to Table 6 for recommendations on refrigeration specialties.

Select the filter drier for maximum unit capacity and minimum pressure drop. Complete the refrigerant piping from the indoor unit to the outdoor unit before opening the liquid and suction lines at the outdoor unit.

Install Liquid Line Solenoid Valve —

It is recommended that a solenoid valve be placed in the main liquid line (see Fig. 6) between the condensing unit and the evaporator coil. Locate the solenoid valve at the outlet end of the liquid line, near the evaporator coil connections, with flow direction arrow pointed at the evaporator coil. Refer to Table 6. (A liquid line solenoid valve is required when the liquid line length exceeds 75 ft [23 m].) This valve prevents refrigerant migration (which causes oil dilution) to the compressor during the off cycle, at low outdoor ambient temperatures. Wire the solenoid in parallel with the compressor contactor coil (see Fig. 6). This means of electrical control is referred to as solenoid drop control.

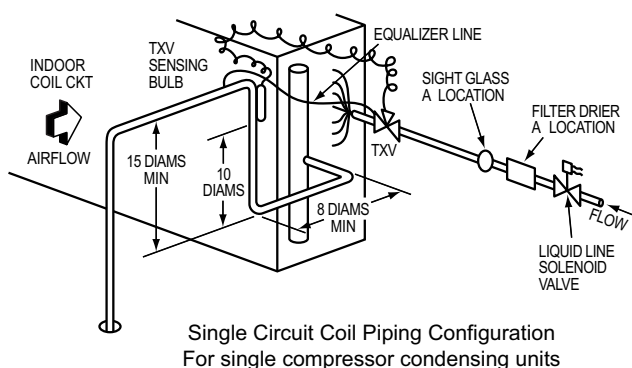

Fig. 6 - Location of Sight Glass and Filter Drier

Solenoid drop control wiring: Control the power to the liquid line solenoid through a Solenoid Valve Relay (SVR) in all units. Use part number HN61PC005 (field-supplied, installed). 569J*08G/H unit requires one SVR.

Evaporator Capacity Control Liquid Line Solenoid Valve:

Many older unit designs included automatic capacity controls that sensed changes in suction pressure and could increase or decrease compressor capacity automatically as the evaporator load changed. Control systems were used on these units that had the thermostat’s second stage contacts control a capacity control liquid line solenoid valve to open or shutoff a portion of the evaporator surface without any direct connection to the compressor circuit.

This form of system capacity staging control is not possible with 569J models. If this installation is a retrofit for a unit that included automatic pressure-operated unloading, check the existing thermostat and liquid solenoid valve. When found, convert the evaporator second stage solenoid control into a drop-solenoid control.

Selecting an Accumulator —

Because all 569J models use scroll compressors, an accumulator is not required. If an accumulator is to be added, check the accumulator manufacturer’s literature carefully for indication of its suitability for use with R-410A; look for minimum working pressure of 200 psig (1380 kPa). Select the accumulator first on the basis of its cataloged minimum capacity (tons) to ensure oil return from the accumulator, then on tube size or holding capacity.

Make Piping Connections —

Piping connections at the 569J unit are ball valves with stub tube extensions. Do not open the unit service valves until all interconnecting tube brazing has been completed.

The stub tube connections include 1/4-in SAE service fittings with Schrader valve cores (see Fig. 7). Before making any brazed connections to the unit service valves, remove both Schrader valve caps and cores and save for re-installation. Connect a source for nitrogen to one of these service fittings during tube brazing to prevent the formation of copper oxides inside the tubes at brazed joints.

When connecting the field tubing to the 569J service valves, wrap the valves in wet rags to prevent overheating.

Pressure-test all joints from outdoor unit connections over to the evaporator coil, using nitrogen as pressure and with soap-and-bubbles.

When pressure-testing is completed, remove the nitrogen source at the outdoor unit service valves and re-install the two Schrader valve cores. Torque the cores to 2-3 in-lbs (23-34 N-cm).

569J*08G/H

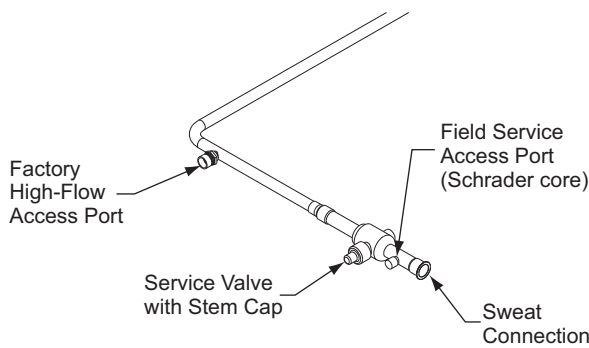

C10203

Fig. 7 - Typical Piping Connection Assembly

Evacuation/Dehydration —

Evacuate and dehydrate the connected refrigeration system(s) (excluding the 569J*08G/H unit) to 500 microns using a two-stage vacuum pump attached to the service ports outside the 569J service valves, following description in GTAC II, Module 4, System Dehydration.

569J*08G/H

⚠ WARNING

UNIT OPERATION AND SAFETY HAZARD

Failure to follow this warning could cause personal injury, death and/or equipment damage.

Puron® (R-410A) refrigerant systems operate at higher pressure than standard R-22 systems. Do not use R-22 service equipment or components on Puron refrigerant equipment.

This unit is designed for use with Puron (R-410A) refrigerant. Do not use any other refrigerant in this system.

Puron (R-410A) refrigerant is provided in pink (rose) colored cylinders. These cylinders are available with and without dip tubes; cylinders with dip tubes will have a label indicating this feature. For a cylinder with a dip tube, place the cylinder in the upright position (access valve at the top) when removing liquid refrigerant for charging. For a cylinder without a dip tube, invert the cylinder (access valve on the bottom) when removing liquid refrigerant.

Because Puron (R-410A) refrigerant is a blend, it is strongly recommended that refrigerant always be removed from the cylinder as a liquid. Admit liquid refrigerant into the system in the discharge line. If adding refrigerant into the suction line, use a commercial metering/expansion device at the gauge manifold; remove liquid from the cylinder, pass it through the metering device at the gauge set and then pass it into the suction line as a vapor. Do not remove Puron (R-410A) refrigerant from the cylinder as a vapor.

Preliminary Charge —

Before starting the unit, charge R-410A liquid refrigerant into the high side of each 569J circuit through the liquid service valve(s). The amount of refrigerant added must be at least 80% of the operating charge listed in Table 3 for LINEAR line length LESS the factory charge quantity (if

factory shipping charge has not been removed). See example below.

Allow high and low side pressures to equalize. If pressures do not equalize readily, charge R-410A vapor (using special service manifold with expansion device) into the suction line service port for the low side of system to assure charge in the evaporator. Refer to GTAC II, Module 5, Charging, Recover, Recycling, and Reclamation for liquid charging procedures.

Example:

569J*08G/H (RTPF)

60-ft (18.3 m) linear line length

Equivalent line length 90-ft (27.4 m)

Liquid Lift: 20-ft (6.1 m)

Select line sizes from Table 3 (569J):

Liquid 1/2 in

Suction 1 1/8 in.

Charge 22.5 lbs (at 75-ft linear length)

80% of Operating Charge:

0.80 x 22.5 = 18 lbs

Factory Shipping Charge: 14 lbs

Field-Charge quantity: 18 - 14 = 4 lbs

For linear line lengths longer than 125 ft (38 m), contact your local Bryant representative for system charge value.

Step 7 — Install Accessories

Accessories requiring modifications to unit wiring should be completed now. These accessories may include Winter Start controls and Low Ambient controls. Refer to the instructions shipped with the accessory.

Step 8 — Complete Electrical Connections

⚠ WARNING

ELECTRICAL SHOCK HAZARD

Failure to follow this warning could result in personal injury or death.

Do not use gas piping as an electrical ground. Unit cabinet must have an uninterrupted, unbroken electrical ground to minimize the possibility of personal injury if an electrical fault should occur. This ground may consist of electrical wire connected to unit ground lug in control compartment, or conduit approved for electrical ground when installed in accordance with NEC (National Electrical Code); ANSI/NFPA 70, latest edition (in Canada, Canadian Electrical Code CSA [Canadian Standards Association] C22.1), and local electrical codes.

NOTE: Check all factory and field electrical connections for tightness. Field-supplied wiring shall conform with the limitations of 63°F (33°C) rise.

Field Power Supply —

If equipped with optional Powered Convenience Outlet: The power source leads to the convenience outlet's transformer primary are not factory connected. Installer must connect these leads according to required operation of the convenience outlet. If an always-energized convenience outlet operation is desired, connect the source leads to the line side of the unit-mounted disconnect. (Check with local codes to ensure this method is acceptable in your area.) If a de-energize via unit disconnect switch operation of the convenience outlet is desired, connect the source leads to the load side of the unit disconnect. On a unit without a unit-mounted disconnect, connect the source leads to compressor contactor C and indoor fan contactor IFC pressure lugs with unit field power leads..

Refer to Fig. 13 for power transformer connections and the discussion on connecting the convenience outlet on page 12.

Field power wires are connected to the unit at line-side pressure lugs on compressor contactor C and TB1 (see wiring diagram label for control box component arrangement) or at factory-installed option non-fused disconnect switch. Max wire size is #4 AWG (copper only).

NOTE: TEST LEADS - Unit may be equipped with short leads (pigtailed) on the field line connection points on contactor C or optional disconnect switch. These leads are for factory run-test purposes only; remove and discard before connecting field power wires to unit connection points. Make field power connections directly to line connection pressure lugs only.

⚠ WARNING

FIRE HAZARD

Failure to follow this warning could cause in personal injury, death and/or equipment damage.

Do not connect aluminum wire between disconnect switch and condensing unit. Use only copper wire. (See Fig. 8.)

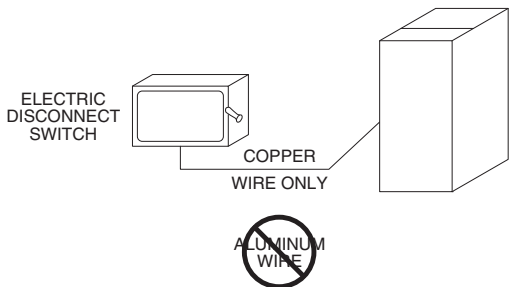

Fig. 8 - Disconnect Switch and Unit

A93033

Units with Factory-Installed Non-Fused Disconnect —

The factory-installed option non-fused disconnect (NFD) switch is located in a weatherproof enclosure located under the main control box. The manual switch handle and shaft are shipped in the disconnect enclosure. Assemble the

shaft and handle to the switch at this point. Discard the factory test leads (see Fig. 9).

Units Without Disconnect Option

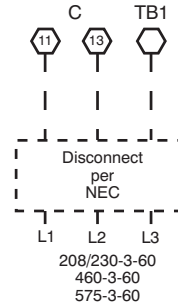

Units With Disconnect Option

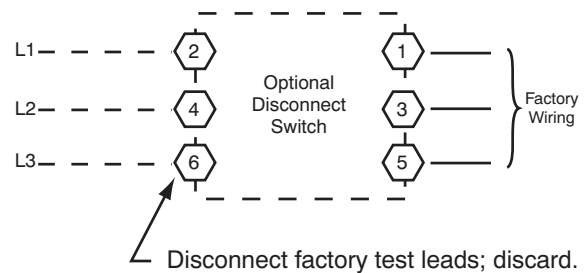

C10204

Fig. 9 - Power Wiring Connections

Connect field power supply conductors to LINE side terminals when the switch enclosure cover is removed to attach the handle.

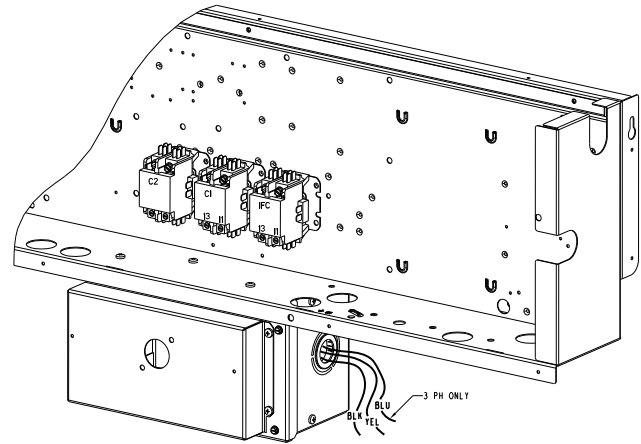

C12284

Fig. 10 - Location of Non-Fused Disconnect Enclosure

To field install the NFD shaft and handle:

1. Remove the unit front pane (see Fig. 2).
2. Remove (3) hex screws on the NFD enclosure - (2) on the face of the cover and (1) on the left side cover.
3. Remove the front cover of the NFD enclosure.
4. Make sure the NFD shipped from the factory is at OFF position (the arrow on the black handle knob is at OFF).
5. Insert the shaft with the cross pin on the top of the shaft in the horizontal position.

6. Measure from the tip of the shaft to the top surface of the black pointer; the measurement should be 3.75 - 3.88 in. (95 - 99 mm).
7. Tighten the locking screw to secure the shaft to the NFD.
8. Turn the handle to the OFF position with red arrow pointing at OFF.
9. Install the handle on to the painted cover horizontally with the red arrow pointing to the left.
10. Secure the handle to the painted cover with (2) screws and lock washers supplied.
11. Engaging the shaft into the handle socket, re-install (3) hex screws on the NFD enclosure.
12. Re-install the unit front panel.

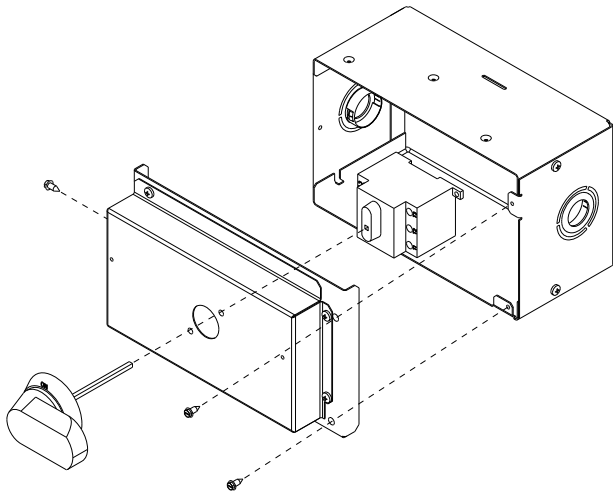

C12279

Fig. 11 - Handle and Shaft Assembly for NFD

Units Without Factory-Installed Non-Fused Disconnect —

When installing units, provide a disconnect switch per NEC (National Electrical Code) of adequate size. Disconnect sizing data is provided on the unit informative plate. Locate on unit cabinet or within sight of the unit per national or local codes. Do not cover unit informative plate if mounting the disconnect on the unit cabinet.

All Units —

All field wiring must comply with NEC and all local codes. Size wire based on MCA (Minimum Circuit Amps) on the unit informative plate. See Fig. 9 and the unit label diagram for power wiring connections to the unit power terminal blocks and equipment ground. Maximum wire size is #2 ga AWG (copper only) per pole on contactors.

Provide a ground-fault and short-circuit over-current protection device (fuse or breaker) per NEC Article 440 (or local codes). Refer to unit informative data plate for MOCP (Maximum Over-current Protection) device size.

All field wiring must comply with the NEC and local requirements.

All units except 208/230-v units are factory wired for the voltage shown on the nameplate. *If the 208/230-v unit is to be connected to a 208-v power supply, the control transformer must be rewired by moving the black wire with*

the 1/4-in. female spade connector from the 230-v connection and moving it to the 208-v 1/4-in. male terminal on the primary side of the transformer. Refer to unit label diagram for line-side information. Field power wires will be connected line-side pressure lugs on the power terminal block or at factory-installed option non-fused disconnect.

NOTE: Check all factory and field electrical connections for tightness.

Affix the crankcase heater warning sticker to the unit disconnect switch.

Voltage and Current Balance —

Voltage to compressor terminals during operation must be within voltage range indicated on unit nameplate. See Table 7. On 3-phase units, voltages between phases must be balanced within 2% and the current within 10%. Use the formula shown in the legend for Table 7, Note 4 (see page 15) to determine the percent of voltage imbalance. Operation on improper line voltage or excessive phase imbalance constitutes abuse and may cause damage to electrical components. Such operation would invalidate any applicable Bryant warranty.

Convenience Outlets —

⚠ WARNING

ELECTRICAL OPERATION HAZARD

Failure to follow this warning could result in personal injury or death.

Units with convenience outlet circuits may use multiple disconnects. Check convenience outlet for power status before opening unit for service. Locate its disconnect switch, if appropriate, and open it. Tag-out this switch, if necessary.

Two types of convenience outlets are offered on 569J models: Non-powered and unit-powered. Both types provide a 125-volt GFCI (ground-fault circuit-interrupter) duplex receptacle rated at 15-A behind a hinged waterproof access cover, located on the end panel of the unit. See Fig. 12.

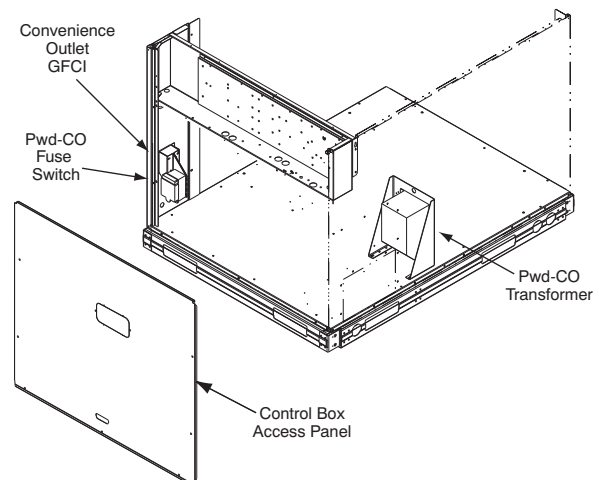

C10936

Fig. 12 - Convenience Outlet Location

Non-powered type: This type requires the field installation of a general-purpose 125-volt 15-A circuit powered from a source elsewhere in the building. Observe national and local codes when selecting wire size, fuse or breaker requirements and disconnect switch size and location. Route 125-v power supply conductors into the bottom of the utility box containing the duplex receptacle.

Maximum continuous current for this type of convenience outlet (non-unit powered) must not exceed 8 Amps.

Unit-powered type: A unit-mounted transformer is factory-installed to stepdown the main power supply voltage to the unit to 115-v at the duplex receptacle. This option also includes a manual switch with fuse, located in a utility box and mounted on a bracket behind the convenience outlet; access is through the unit's control box access panel. See Fig. 12.

The primary leads to the convenience outlet transformer are not factory-connected. Selection of primary power source is a customer-option. If local codes permit, the transformer primary leads can be connected at the line-side terminals on the unit-mounted non-fused disconnect or HACR breaker switch; this will provide service power to the unit when the unit disconnect switch or HACR switch is open. Other connection methods will result in the convenience outlet circuit being de-energized when the unit disconnect or HACR switch is open. See Fig. 13.

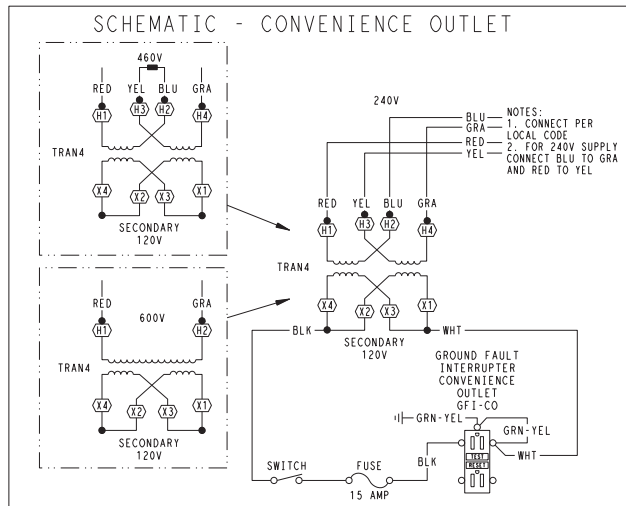

C10206

UNIT VOLTAGE	CONNECT AS	PRIMARY CONNECTIONS	TRANSFORMER TERMINALS
208, 230	240	L1: RED + YEL L2: BLU + GRA	H1 + H3 H2 + H4
460	480	L1: RED Splice BLU + YEL L2: GRA	H1 H2 + H3 H4
575	600	L1: RED L2: GRA	H1 H2

Fig. 13 - Powered Convenience Outlet Wiring

The unit-powered convenience outlet has a 1000 VA rated transformer. Maximum continuous current must not exceed 8 Amps.

Test the GFCI receptacle by pressing the TEST button on the face of the receptacle to trip and open the receptacle. Check for proper grounding wires and power line phasing if the GFCI receptacle does not trip as required. Press the RESET button to clear the tripped condition.

Fuse on power type: The factory fuse is a Bussman "Fusetron" T-15, non-renewable screw-in (Edison base) type plug fuse.

⚠ WARNING

ELECTRICAL OPERATION HAZARD

Failure to follow this warning could result in personal injury or death.

Using unit-mounted convenience outlets: Units with unit-mounted convenience outlet circuits will often require that two disconnects be opened to de-energize all power to the unit. Treat all units as electrically energized until the convenience outlet power is also checked and de-energization is confirmed. Observe National Electrical Code Article 210, Branch Circuits, for use of convenience outlets.

569J*08G/H

Installing Weatherproof Cover: A weatherproof while in use cover for the factory installed convenience outlets is now required by UL standards. This cover cannot be factory mounted due its depth; it must be installed at unit installation. For shipment, the convenience outlet is covered with a blank cover plate.

The weatherproof cover kit is shipped in the unit's control box. The kit includes the hinged cover, a backing plate and gasket.

DISCONNECT ALL POWER TO UNIT AND CONVENIENCE OUTLET.

Remove the blank cover plate at the convenience outlet; discard the blank cover.

Loosen the two screws at the GFCI duplex outlet, until approximately $\frac{1}{2}$ in (13 mm) under screw heads are exposed. Press the gasket over the screw heads. Slip the backing plate over the screw heads at the keyhole slots and align with the gasket; tighten the two screws until snug (do not overtighten).

Mount the weatherproof cover to the backing plate as shown in Fig. 14. Remove two slot fillers in the bottom of the cover to permit service tool cords to exit the cover. Check for full closing and latching.

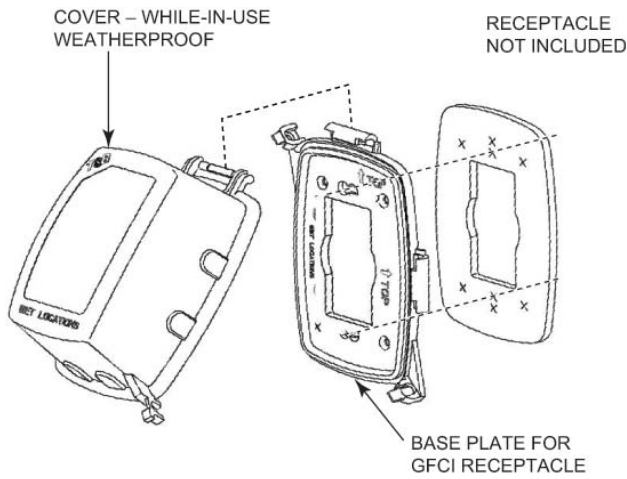

C09022

Fig. 14 - Weatherproof Cover Installation

All Units —

Voltage to compressor terminals during operation must be within voltage range indicated on unit nameplate. See Table 7. On 3-phase units, voltages between phases must be balanced within 2% and the current within 10%. Use the formula shown in the legend for Table 7, Note 4 (see page 15) to determine the percent of voltage imbalance. Operation on improper line voltage or excessive phase imbalance constitutes abuse and may cause damage to electrical components. Such operation would invalidate any applicable Bryant warranty.

Field Control Wiring —

569J unit control voltage is 24 v. See Fig. 20 for typical field control connections and the unit's label diagram for field-supplied wiring details. Route control wires to the 569J unit through the opening in unit's end panel to the connections terminal board in the unit's control box.

Remainder of the system controls connection will vary according to the specific construction details of the indoor section (air handler or packaged fan coil). Fig. 15 depicts typical connections to a Bryant 524J fan coil unit. Plan for field connections carefully and install control wiring correctly per the project plan. Additional components and supplemental transformer accessory may be required.

The 569J unit requires an external temperature control device. This device can be a thermostat (field-supplied) or a thermostat emulation device provided as part of a third-party Building Management System).

Thermostat —

Install a Bryant-approved accessory thermostat according to installation instructions included with the accessory. Locate the thermostat accessory on a solid wall in the conditioned space to sense average temperature in accordance with the thermostat installation instructions.

The 569J*08G/H unit is a single-circuit, two-stage cooling unit. Select a two-stage cooling thermostat, with or without supplemental heating, as needed.

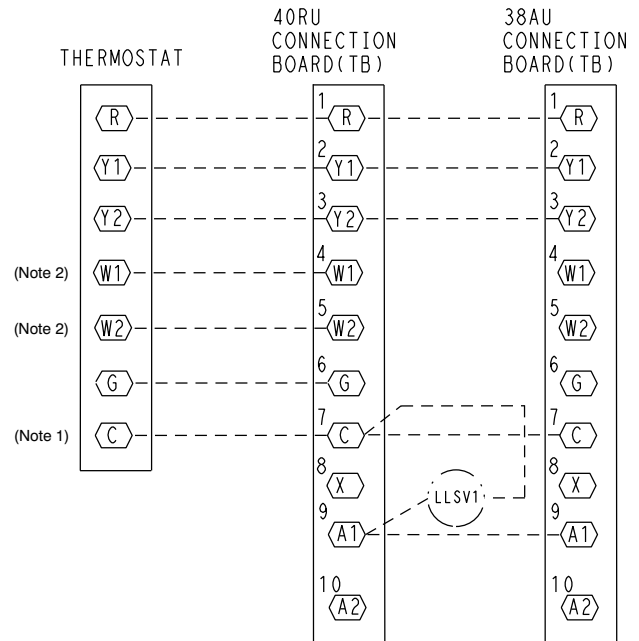

Note 1: Connect only if thermostat requires 24-vac power source.
 Note 2: Connect W1 and W2 if supplemental heaters are installed
 - - - Field Wiring

C14292

Fig. 15 - Typical Remote Thermostat Connections

Select a thermostat cable or equivalent single leads of different colors with minimum of five leads for 569J*08G/H units. Check the thermostat installation instructions for additional features which might require additional conductors in the cable.

For wire runs up to 50 ft. (15 m), use no. 18 AWG (American Wire Gauge) insulated wire (35°C minimum). For 50 to 75 ft. (15 to 23 m), use no. 16 AWG insulated wire (35°C minimum). For over 75 ft. (23 m), use no. 14 AWG insulated wire (35°C minimum). All wire sizes larger than no. 18 AWG cannot be directly connected to the thermostat and will require a junction box and splice at the thermostat.

If the unit will be operating at 208-3-60 power, remove the black wire (BLK) from the transformer primary connection labelled "230" and move it to the connection labelled "208". See Fig. 16.

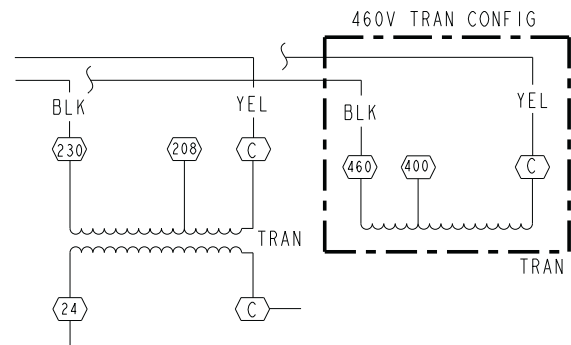

C10079

Fig. 16 - Control Transformer Wiring

External Devices —

The 569J control transformers provide 24-v NEC Class 2 power sources to energize external control devices. These devices will include the indoor fan motor contactor (or control relay). These devices may also include liquid line solenoid valve, economizer control relay, supplemental electric heater contactors or control relays and other devices selected by system designer.

Control transformer TRAN1 provides control power through terminal R to C on the field connection terminal strip TB for supply fan motor interlock. This source may also be used to energize economizer control relay and electric heater contactors or relays. Maximum available power is 20 va. Check concurrent loadings by external control devices. If the maximum concurrent loading exceeds 20 va, purchase and install the accessory Transformer-Relay package (available for 208/230 and 460-v units).

Table 7 – Electrical Data — 569J*08G/H 60 Hz Units

WITH POWERED CONVENIENCE OUTLET											
UNIT	V-Ph-Hz	VOLTAGE RANGE [‡]		COMPRESSOR		OFM (ea)		POWER SUPPLY		DISCONNECT SIZE	
		MIN	MAX	RLA	LRA	QTY	FLA	MCA	MOCP	FLA	LRA
569J*08G/H	208/230-3-60	187	253	24.0	186	2	1.5	38	60	37	197
	460-3-60	414	506	12.6	100	2	0.8	20	30	19	106
	575-3-60	518	633	9.9	78	2	0.7	16	25	15	84

WITHOUT POWERED CONVENIENCE OUTLET											
UNIT	V-Ph-Hz	VOLTAGE RANGE [‡]		COMPRESSOR		OFM (ea)		POWER SUPPLY		DISCONNECT SIZE	
		MIN	MAX	RLA	LRA	QTY	FLA	MCA	MOCP	FLA	LRA
569J*08G/H	208/230-3-60	187	253	24.0	186	2	1.5	33	50	31	192
	460-3-60	414	506	12.6	100	2	0.8	18	25	16	104
	575-3-60	518	633	9.9	78	2	0.6	14	20	13	82

569J*08G/H

Legend and Notes for Table 7

LEGEND:

- FLA - Full Load Amps
- LRA - Locked Rotor Amps
- MOCP - Maximum Over Current Protection
- NEC - National Electrical Code
- RLA - Rated Load Amps

[‡] Units are suitable for use on electrical systems where voltage supplied to the unit terminals is not below or above the listed limits.

NOTES:

1. The MCA and Fuse values are calculated in accordance with The NEC, Article 440.
2. Motor RLA and LRA values are established in accordance with Underwriters' Laboratories (UL), Standard 1995.
3. The 575-v units are UL, Canada-listed only.
4. **Unbalanced 3-Phase Supply Voltage**
Never operate a motor where a phase imbalance in supply voltage is greater than 2%. Use the following formula to determine the percentage of voltage imbalance.

Example: Supply voltage is 230-3-60

$$\% \text{ Voltage Imbalance} = 100 \times \frac{\text{max voltage deviation from average voltage}}{\text{average voltage}}$$



- AB = 224 v
- BC = 231 v
- AC = 226 v

$$\text{Average Voltage} = \frac{(224 + 231 + 226)}{3} = \frac{681}{3} = 227$$

Determine maximum deviation from average voltage.

- (AB) 227 - 224 = 3 v
- (BC) 231 - 227 = 4 v
- (AC) 227 - 226 = 1 v

Maximum deviation is 4 v.

Determine percent of voltage imbalance.

$$\% \text{ Voltage Imbalance} = 100 \times \frac{4}{227} = 1.76\%$$

This amount of phase imbalance is satisfactory as it is below the maximum allowable 2%.

IMPORTANT: If the supply voltage phase imbalance is more than 2%, contact your local electric utility company immediately.

Step 9 — Wind Baffles for Low Ambient Control

569J*08H includes the factory installed 32LT Motormaster Low Ambient Control.

Units with 32LT Motormaster control require the addition of wind baffles to ensure full range low ambient operation. Material data and dimensions for wind baffles are included in the Appendix C section, Low Ambient Control, starting on page 29. Fabricate the wind baffles and mount per instructions.

PRE-START-UP

IMPORTANT: Before beginning Pre-Start-Up or Start-Up, review Start-Up Checklist at the back of this book. The Checklist assures proper start-up of a unit and provides a record of unit condition, application requirements, system information, and operation at initial start-up.

⚠ CAUTION

UNIT DAMAGE HAZARD

Failure to follow this caution may result in equipment damage.

Do not attempt to start the condensing unit, even momentarily, until the following steps have been completed. Compressor damage may result.

System Check

1. The electrical power source must agree with the unit's nameplate rating.
2. Check all air handler(s) and other equipment auxiliary components. Consult the manufacturer's instructions regarding any other equipment connected to the condensing unit. If the unit has field-installed accessories, be sure all are properly installed and correctly wired. If used, the airflow switch must be properly installed.
3. Check tightness of all electrical connections.
4. Be sure liquid line and low side of the system are properly leak checked and dehydrated.
5. Be sure the unit is properly charged. See "Preliminary Charge", below.
6. Open the liquid line and suction line service valves.
7. The crankcase heater must be firmly attached to the compressor crankcase. Be sure the crankcase is warm (heater must be on for 24 hours before starting compressor).

Turn On Crankcase Heater —

Turn on the crankcase heater for 24 hours before starting the unit to be sure all the refrigerant is out of the oil. To energize the crankcase heater, proceed as follows:

1. Set the space thermostat set point above the space temperature so there is no demand for cooling.
2. Close the field disconnect.

Preliminary Charge —

Before starting the unit, charge liquid refrigerant into the high side of the system through the liquid service valve. The amount of refrigerant added must be at least 80% of the operating charge listed in the Physical Data table (Tables 1 and 2 on page 5). Allow high and low side pressures to equalize before starting compressor. If pressures do not equalize readily, charge vapor on low side of system to assure charge in the evaporator. Refer to GTAC II, Module 5, Charging, Recover, Recycling, and Reclamation for liquid charging procedures.

⚠ CAUTION

UNIT DAMAGE HAZARD

Failure to follow this caution may result in equipment damage.

Prior to starting compressor, a preliminary charge of refrigerant must be added to avoid possible compressor damage.

START-UP

569J Units: The compressor crankcase heater must be on for 24 hours before start-up. After the heater has been on for 24 hours, the unit can be started. If no time elapsed since the preliminary charge step was completed, it is unnecessary to wait the 24-hour period.

Preliminary Checks

1. Check that electric power supply agrees with unit nameplate data.
2. Verify that the compressor crankcase heater is securely in place.
3. Check that the compressor crankcase heater has been on at least 24 hours.
4. Recheck for leaks using the procedure outlined in the Pre-Start-Up section, Leak Test and Dehydration. If any leaks are detected, repair as required. Evacuate and dehydrate as described in the Leak Test and Dehydration section.
5. Ensure that the preliminary charge has been added as described in the Pre-Start-Up section, Preliminary Charge.
6. All internal wiring connections must be tight, and all barriers and covers must be in place.

NOTE: The 569J units are factory charged with the required amount of oil. If recharging is required, use Emkarate RL 32-3MAF for the 569J units.

Compressor Rotation —

On 3-phase units with scroll compressors, it is important to be certain that the compressor is rotating in the proper direction. 569J units are equipped with a Comfort Alert Diagnostic Module (CADM). Alert Code 7 indicates reverse power phasing.

To correct phase order:

1. Turn off power to the unit, tag disconnect.
2. Reverse any two of the unit power leads.
3. Reapply power to the compressor, verify correct pressures.

To verify the compressor is rotating in the proper direction:

1. Connect service gages to the suction and liquid pressure fittings.
2. Energize the compressor.
3. The suction pressure should drop and the liquid pressure should rise, as is normal on any start-up.

Compressor Overload —

This overload interrupts power to the compressor when either the current or internal motor winding temperature becomes excessive, and automatically resets when the internal temperature drops to a safe level. This overload may require up to 60 minutes (or longer) to reset. If the internal overload is suspected of being open, disconnect the electrical power to the unit and check the circuit through the overload with an ohmmeter or continuity tester.

Advanced Scroll Temperature Protection (ASTP) —

A label located above the terminal box identifies Copeland Scroll compressor models that contain this technology. See Fig. 17. Advanced Scroll Temperature Protection (ASTP) is a form of internal discharge temperature protection, that unloads the scroll compressor when the internal temperature reaches approximately 149°C (300°F). At this temperature, an internal bi-metal disk valve opens and causes the scroll elements to separate, which stops compression. Suction and discharge pressures balance while the motor continues to run. The longer the compressor runs unloaded, the longer it must cool before the bi-metal disk resets. See Fig. 18.

To manually reset ASTP, the compressor should be stopped and allowed to cool. If the compressor is not stopped, the motor will run until the motor protector trips, which occurs up to 90 minutes later. Advanced Scroll Temperature Protection will reset automatically before the motor protector resets, which may take up to 2 hours.



Fig. 17 - Advanced Scroll Temperature Protection Label

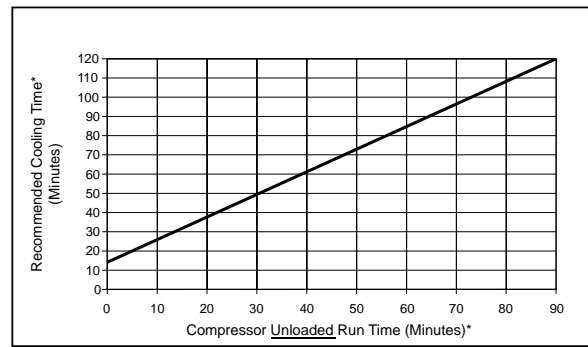

*Times are approximate.

NOTE: Various factors, including high humidity, high ambient temperature, and the presence of a sound blanket will increase cool-down times.

C10081

Fig. 18 - Recommended Minimum Cool-Down Time After Compressor is Stopped

Start Unit

Set the space thermostat to a set point above space temperature so that there is no demand for cooling. Close the 569J disconnect switch. Only the crankcase heater will be energized.

Reset the space thermostat below ambient so that a call for cooling is ensured.

⚠ CAUTION

UNIT DAMAGE HAZARD

Failure to follow this caution may result in equipment damage.

Never charge liquid into the low-pressure side of system. Do not overcharge. During charging or removal of refrigerant, be sure indoor-fan system is operating. Ensure both outdoor fan motors are running; bypass any Motormaster function.

Adjust Refrigerant Charge —

Refer to Cooling Charging Chart, Fig. 19. For applications with line lengths greater than 125 ft (38 m), contact Bryant representative. Vary refrigerant until the conditions of the chart are met. Note that the charging charts are different from the type normally used. The charts are based on charging the units to the correct subcooling for the various operating conditions. Accurate pressure gage and temperature sensing device are required. Connect the pressure gage to the service port on the liquid line service valve. Mount the temperature sensing device on the liquid line close to the liquid line service valve, and insulate it so that outdoor ambient temperature does not affect the reading. Indoor airflow must be within the unit's normal operating range. Operate the unit for a minimum of 15 minutes. Ensure that pressure and temperature readings have stabilized. Plot the liquid pressure and temperature on chart and add or reduce the charge to meet the curve. Adjust the charge to conform with the charging chart, using the liquid pressure and temperature to read the chart.

569J*08G/H

Using plotted operating point:

If plotted operating condition is -	Adjust charge by -
BELOW the curve	REDUCE charge
ABOVE the curve	ADD charge

Final Checks —

Ensure that all safety controls are operating, control panel covers are on, and the service panels are in place.

569J*08G/H

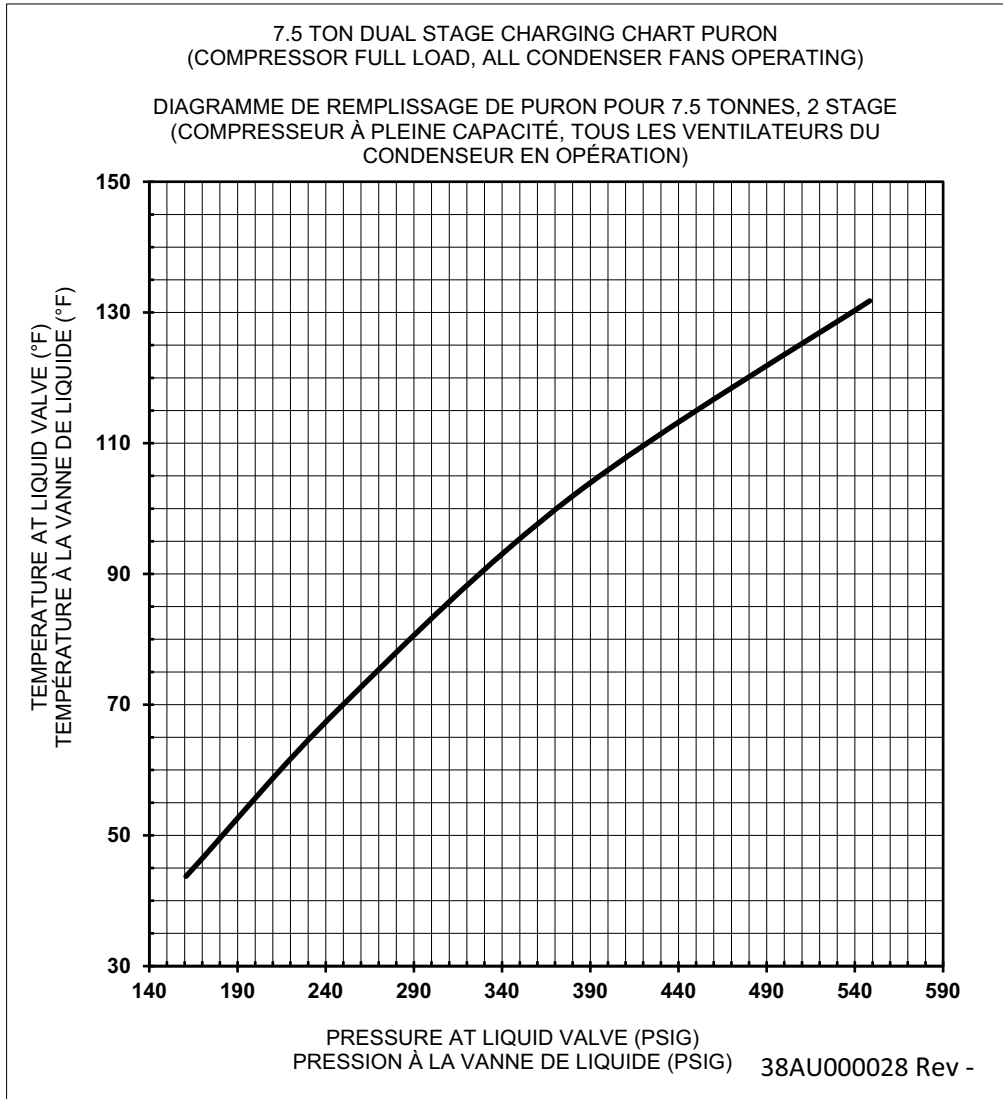
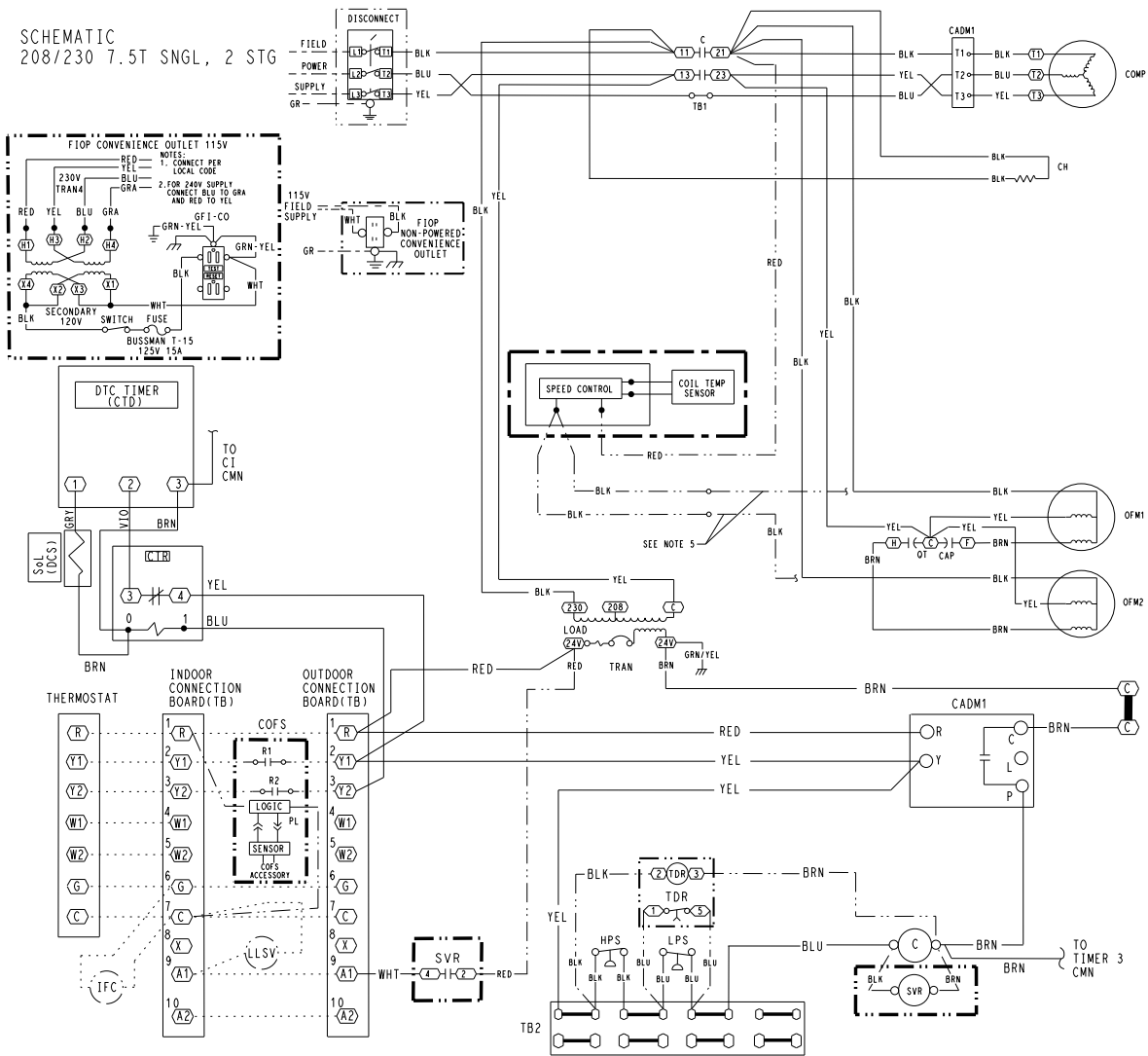

Fig. 19 - 569J*08G/H Charging Chart

C14293

SCHEMATIC
208/230 7.5T SNGL, 2 STG



569J*08G/H

CONTROL BOX COMPONENT ARRANGEMENT

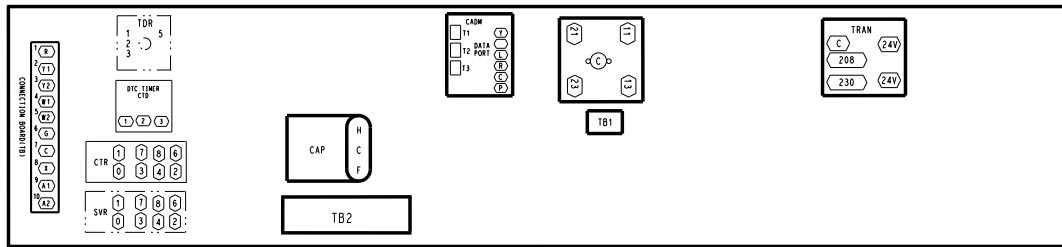

- FIELD CONTROL WIRING**
- △ FIELD SPICE
 - ② MARKED WIRE
 - ⓧ TERMINAL (MARKED)
 - TERMINAL (UNMARKED)
 - ⓧ TERMINAL BLOCK
 - SPLICE
 - FACTORY WIRING
 - - - FIELD CONTROL WIRING
 - - - FIELD POWER WIRING
 - - - ACCESSORY OR OPTIONAL WIRING
 - TO INDICATE COMMON POTENTIAL ONLY, NOT TO REPRESENT WIRING

- LEGEND**
- C CONTACTOR, COMPRESSOR
 - CAP CAPACITOR
 - CADM COMFORT ALERT - DIAGNOSTICS MODULE
 - CH CRANKCASE HEATER
 - COFS CONDENSATE OVERFLOW SWITCH
 - COMP COMPRESSOR MOTOR
 - CTD CYCLE TIMER DEVICE
 - CTR COMPRESSOR TIMERR RELAY
 - DCS DIGITAL COMPRESSOR SOLENOID
 - EQUIP EQUIPMENT
 - FU FUSE
 - GR GROUND
 - HPS HIGH PRESSURE SWITCH
 - IFC INDOOR FAN CONTACTOR
 - LLSV LIQUID LINE SOLENOID VALVE
 - LPS LOW PRESSURE SWITCH
 - OFM OUTDOOR FAN MOTOR
 - OFR OUTDOOR FAN RELAY
 - OTR QUADRUPEL TERMINAL
 - SVR SOLENOID VALVE RELAY
 - TB TERMINAL BLOCK
 - TDR TIME DELAY RELAY
 - TRAN TRANSFORMER

- NOTES:**
1. IF ANY OF THE ORIGINAL WIRE FURNISHED MUST BE REPLACED, IT MUST BE REPLACED WITH TYPE 90 C WIRE OR ITS EQUIVALENT.
 2. USE COPPER CONDUCTORS ONLY.
 3. COMPRESSORS AND FAN MOTORS ARE THERMALLY PROTECTED. THREE PHASE MOTORS ARE PROTECTED AGAINST PRIMARY SINGLE PHASING CONDITIONS.
 4. TRANSFORMER IS WIRED FOR 230V UNIT. IF THE UNIT IS TO BE RUN WITH 208V POWER SUPPLY, DISCONNECT BLACK WIRE FROM 230V TAP AND CONNECT TO 208V TAP.
 5. ON UNITS WITH SPEED CONTROL, REMOVE OFM1 AND OFM2 BLK WIRES FROM COMPRESSOR CONTACTOR TERMINAL 21 AND CONNECT TO BLK WIRES FROM SPEED CONTROL.

38AU00026 A

Fig. 20 - Typical 569J*08G/H Wiring Diagram - 208/230V-3PH-60Hz Unit Shown

OPERATING SEQUENCE

Base Unit Controls

Indoor (Supply) Fan —

The indoor fan contactor (IFC) is remotely located at the fan coil or fan section. If the thermostat fan operation is selected as Continuous, the IFC is energized and the indoor (supply) fan motor runs continuously. If the thermostat fan operation is selected as Automatic, the IFC will be energized on a call for Cooling; indoor (supply) fan motor runs. When thermostat call for Cooling is satisfied, the IFC is de-energized and indoor (supply) fan motor stops.

Cooling, Unit Without Economizer —

On a thermostat call for Cooling, IFC will be energized and indoor (supply) fan motor runs. Thermostat output Y1 is energized; terminal Y1 at 569J unit receives 24-v. 24-v received at CADM1 terminal Y. If anti-recycle time delay period has not expired, CADM1 relay will remain open, de-energizing Solenoid Valve Relay (SVR) and preventing compressor start. When safety pressure switches are closed and CADM1 time delay expires, CADM1 relay closes, SVR and compressor contactor C1 are energized; Compressor Relay Timer (CTR) is closed and Digital Cycle Timer (CTD) is energized commanding Digital Compressor Solenoid (DCS) on, liquid line solenoid valve LLSV opens, all outdoor fan motors start and Compressor starts part load operation.

On thermostat call for Stage 2 Cooling, thermostat output Y2 is energized CTR receives 24-v at terminal 1 changing contacts to open. CTD is de-energized and commands DCS off, Compressor operates at full load.

As space cooling load is satisfied, thermostat outputs Y2 and Y1 are sequentially de-energized, removing 24-v at 569J terminals Y1 and Y2. Compressor resumes part load operation on Y2 opening. On Y1 opening, Compressor 1 stops, all outdoor fan motors stop and SVR is de-energized. Liquid Line solenoid valve is de-energized and valve closes. CADM1 begins its three-minute anti-recycle time delay.

If either the Low Pressure Switch or High Pressure Switch opens while thermostat output Y1 or Y2 remain energized, the compressor contactor is de-energized, the compressor stops and liquid line solenoid is de-energized (valve closes). CADM initiates a TRIP event (cooling demand sensed at CADM terminal Y but no current is measured at T1, T2, T3 motor sensors); CADM relay opens and RED LED is illuminated. TRIP condition maintains lockout of compressor operation until CADM is manually reset. Reset CADM by cycling unit main power.

Complete system shutdown may be caused by loss of main power, open compressor internal overload, open low-pressure or high-pressure switch, or a fault detected by the CADM logic. Compressor operation without cooling may indicate the compressor's ASTP feature is active; disconnect unit power and allow compressor to cool. See Service section for further details.

Cooling, Unit With Economizer —

Refer to fan coil unit installation instructions and economizer accessory installation instructions for operating sequences when system is equipped with accessory economizer.

Heating —

Refer to fan coil unit installation instructions and accessory heating device installation instructions for operating sequences in heating mode.

ROUTINE SYSTEM MAINTENANCE

These items should be part of a routine maintenance program, to be checked every month or two, until a specific schedule for each can be identified for this installation:

Quarterly Inspection (and 30 days after initial start) —

Indoor section

- Condenser coil cleanliness checked.
- Return air filter replacement
- Outdoor hood inlet filters cleaned
- Belt tension checked
- Belt condition checked
- Pulley alignment checked
- Fan shaft bearing locking collar tightness checked
- Condensate drain checked

Seasonal Maintenance —

These items should be checked at the beginning of each season (or more often if local conditions and usage patterns dictate):

Air Conditioning

- Condenser fan motor mounting bolts tightness
- Compressor mounting bolts
- Condenser fan blade positioning
- Control box cleanliness and wiring condition
- Wire terminal tightness
- Refrigerant charge level
- Evaporator coil cleaning
- Evaporator blower motor amperage

Heating

- Power wire connections
- Fuses ready
- Manual-reset limit switch is closed

Economizer or Outside Air Damper

- Inlet filters condition
- Check damper travel (economizer)
- Check gear and dampers for debris and dirt

SERVICE

Refrigeration System

⚠ CAUTION

EQUIPMENT DAMAGE HAZARD

Failure to follow this caution may result in damage to equipment.

This system uses Puron[®] refrigerant which has higher pressures than R-22 and other refrigerants. No other refrigerant may be used in this system. Gage set, hoses, and recovery system must be designed to handle Puron. If you are unsure consult the equipment manufacturer.

Compressor Oil —

⚠ CAUTION

EQUIPMENT DAMAGE HAZARD

Failure to follow this caution may result in damage to equipment.

The compressor in a Puron system uses a polyolester (POE) oil. This oil is extremely hygroscopic, meaning it absorbs water readily. POE oils can absorb 15 times as much water as other oils designed for HCFC and CFC refrigerants. Take all necessary precautions to avoid exposure of the oil to the atmosphere.

Servicing Systems on Roofs With Synthetic Materials —

POE (polyolester) compressor lubricants are known to cause long term damage to some synthetic roofing materials. Exposure, even if immediately cleaned up, may cause embrittlement (leading to cracking) to occur in one year or more. When performing any service which may risk exposure of compressor oil to the roof, take appropriate precautions to protect roofing. Procedures which risk oil leakage include but are not limited to compressor replacement, repairing refrigerants leaks, replacing refrigerant components such as filter drier, pressure switch, metering device, coil, accumulator, or reversing valve.

Synthetic Roof Precautionary Procedure:

1. Cover extended roof working area with an impermeable polyethylene (plastic) drop cloth or tarp. Cover an approximate 10 x 10 ft (3.3 x 3.3 m) area.
2. Cover area in front of the unit service panel with a terry cloth shop towel to absorb lubricant spills and prevent run-offs, and protect drop cloth from tears caused by tools or components.

3. Place terry cloth shop towel inside unit immediately under component(s) to be serviced and prevent lubricant run-offs through the louvered openings in the base pan.
4. Perform required service.
5. Remove and dispose of any oil contaminated material per local codes.

Liquid Line Filter Drier —

The factory-provided filter drier is specifically designed to operate with Puron[®]. Replace the filter drier with factory-authorized components only with a filter drier with desiccant made from 100% molecular sieve grade XH-11. Filter drier must be replaced whenever the refrigerant system is opened.

When removing a filter drier, use a tubing cutter to cut the drier from the system. **Do not unsweat a filter drier** from the system. Heat from unsweating will release moisture and contaminants from drier into system.

Field Refrigerant Access Ports —

Field service access to refrigerant pressures is through the access ports located at the service valves (see Fig. 24). These ports are 1/4-in SAE Flare couplings with Schrader check valves and service caps. Use these ports to admit nitrogen to the field tubing during brazing, to evacuate the tubing and evaporator coil, to admit initial refrigerant charge into the low-side of the system and when checking and adjusting the system refrigerant charge. When service activities are completed, ensure the service caps are in place and secure; check for leaks. If the Schrader check valve must be removed and re-installed, tighten to 2-3 in-lbs (23-34 N-cm).

Factory High-Flow Access Ports —

There are two additional access ports in the system - on the suction tube between the compressor and the suction service valve and on the liquid tube near the liquid service valve (see Fig. 25). These are brass fittings with black plastic caps. The hose connection fittings are standard 1/4-in SAE Male Flare couplings.

The brass fittings are two-piece High Flow valves, with a receptacle base brazed to the tubing and an integral spring-closed check valve core screwed into the base. (See Fig. 21) This check valve is permanently assembled into this core body and cannot be serviced separately; replace the entire core body if necessary. Service tools are available from RCD that allow the replacement of the check valve core without having to recover the entire system refrigerant charge. Apply compressor refrigerant oil to the check valve core's bottom o-ring. Install the fitting body with 96 ±10 in-lbs (1085 ±23 N-cm) of torque; do not overtighten.

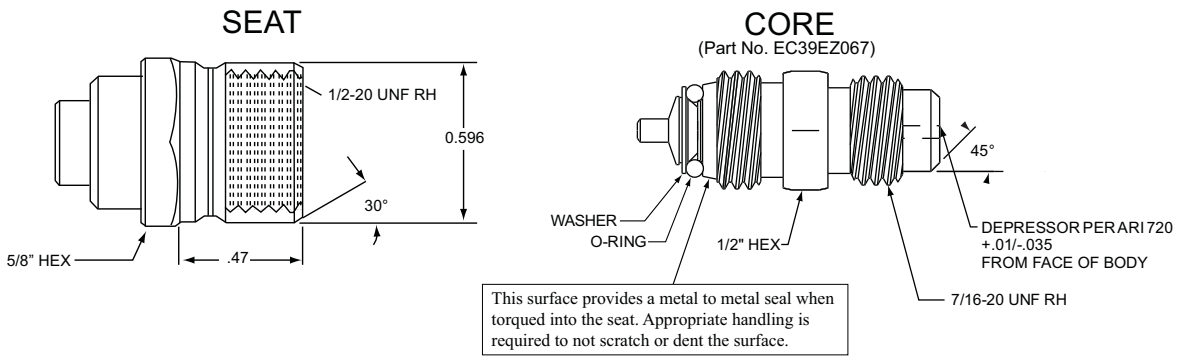

C08453

Fig. 21 - CoreMax Access Port Assembly

Comfort Alert Diagnostic Module

The Comfort Alert Diagnostic Module (CADM) monitors and analyzes data from the Copeland Scroll® three-phase compressor and the thermostat demand. The CADM also provides a 3-minute anti-recycle time delay to compressor cycling. Each compressor has a separate CADM module.

The CADM detects causes for electrical and system related failures without any sensors. Flashing LEDs communicate the Alert codes to guide service technicians in accurately and quickly troubleshooting the system and determining root cause for the failure.

Inputs to the CADM include 24-vac power, thermostat Y1 or Y2, compressor contactor coil (common side) and compressor power leads (from the compressor contactor).

Input	Terminal	Voltage
Control Power	R	24-V
Control Common	C	24-V
Cooling	Y	24-V
Contactor Coil	P	24-V
Line A	T1	Line
Line B	T2	Line
Line C	T3	Line

Control of the compressor contactor coil is through a normally-closed (power on the module) contact between terminals P and C.

Communications of status and alert conditions is through three LEDs located on the top edge of the module housing (see Fig. 22): POWER (green), ALERT (yellow), and TRIP (red).

The POWER LED indicates the presence of control power to the CADM.

The ALERT LED indicates an abnormal condition exists in the system through a flash code. The ALERT LED will blink a number of times consecutively, pause and the repeat the process. The number of blinks, defined in Table 8, correlates to a particular abnormal condition; troubleshooting tips are provided for each Alert code. Reset of the ALERT may be automatic or manual. If the

fault condition causing the Alert is self-corrected, the Alert code will be removed and the CADM will automatically reset and allow the system to restart normally. Manual reset requires that main power to the 569J unit be recycled after the cause for the Alert condition has been detected and corrected.

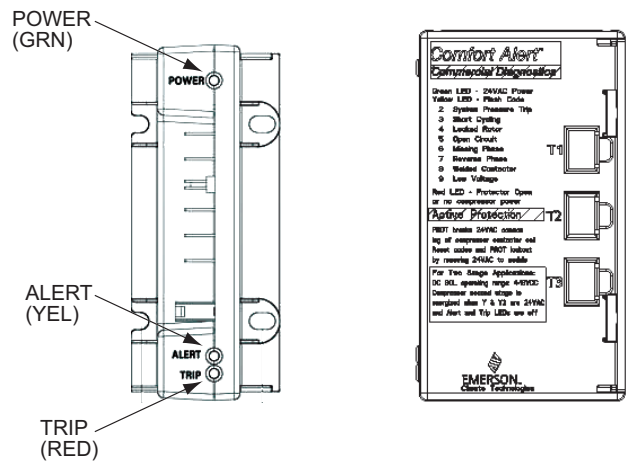

C10086

Fig. 22 - CADM Housing/LED Locations

The TRIP LED indicates either a time-delay period is currently active (RED LED is blinking) or the module has locked out the compressor (RED LED is on steady). A lockout condition will occur when the CADM detects a thermostat demand at input Y but there is no power at the compressor line terminals T1 or T2 or T3. This lockout can occur due to a safety switch (LPS or HPS) opening and de-energizing the compressor contactor, the compressor-motor internal overload opens, or other internal power interruption has occurred. Reset of the TRIP LED requires that unit main power be recycled after the loss of power to the compressor condition has been detected and corrected.

Simultaneous Blinking of YELLOW and RED LEDs indicates control power input to the CADM is low. Check control circuit transformer and wiring.

Troubleshooting the CADM Wiring – Flashing LEDs also indicate wiring problems to the CADM. See Table 9 for discussion of additional LED flash codes and troubleshooting instructions.

Table 8 – LED Status Codes

Status LED	Status LED Description	Status LED Troubleshooting Information
Green "POWER"	Module has power	Supply voltage is present at module terminals
Red "TRIP" LED On Solid	Thermostat demand signal Y is present, but the compressor is not running.	<ol style="list-style-type: none"> 1. Compressor protector is open 2. Condensing unit power disconnect is open 3. Compressor circuit breaker or fuse(s) is open 4. Broken supply wires or connector is not making contact 5. Compressor power wires not routed through Comfort Alert 6. Compressor contactor has failed open
Red "TRIP" LED Flashing	The anti-short cycle timer (3 minutes) in module is preventing compressor restart.	
<p>Module locks out compressor when compressor damaging ALERT code appears. Lockout ALERT codes are noted in the Status LED Description. During a compressor lock out, 24VAC power must be removed from module to manually reset.</p>		
Yellow "ALERT" LED On Solid	A short circuit or over current condition exists on PROT terminal.	<ol style="list-style-type: none"> 1. Compressor contactor coil shorted 2. Electrical load too high for PROT circuit (maximum 1 Amp) 3. 24 V AC wired directly to PROT terminal
Yellow "ALERT" Flash Code 2	System Pressure Trip Discharge pressure out of limits LOCKOUT	<ol style="list-style-type: none"> 1. High head pressure 2. Condenser coil poor air circulation (dirty, blocked, damaged) 3. Condenser fan is not running 4. If low pressure switch is open: <ol style="list-style-type: none"> a. Low refrigerant charge b. Evaporator blower is not running c. Evaporator coil is frozen d. Faulty metering device e. Condenser coil is dirty\ f. Liquid line restriction (filter drier blocked if present)
Yellow "ALERT" Flash Code 3	Short Cycling Compressor is running only briefly (four consecutive cycles of less than three minutes each) LOCKOUT	<ol style="list-style-type: none"> 1. Loose connection between thermostat Y1 and CADM Y terminal. 2. Unit short-cycling on thermostat 3. System or control board defective
Yellow "ALERT" Flash Code 4	Locked Rotor LOCKOUT	<ol style="list-style-type: none"> 1. Low line voltage to compressor 2. Excessive liquid refrigerant in compressor 3. Compressor bearings are seized
Yellow "ALERT" Flash Code 5	Open Circuit	<ol style="list-style-type: none"> 1. Condensing unit power disconnect is open 2. Compressor circuit breaker or fuses are open 3. Compressor contactor has failed open 4. High pressure switch is open and requires manual reset 5. Broken supply wires or connector is not making contact 6. Unusually long compressor protector reset time due to extreme ambient temperature 7. Compressor windings are damaged
Yellow "ALERT" Flash Code 6	Missing Phase LOCKOUT	<ol style="list-style-type: none"> 1. Compressor fuse is open on one phase 2. Broken wire or connector on one phase 3. Compressor motor winding is damaged 4. Utility supply has dropped one phase
Yellow "ALERT" Flash Code 7	Reverse Phase LOCKOUT	<ol style="list-style-type: none"> 1. Compressor running backward due to supply phase reversal
Yellow "ALERT" Flash Code 8	Welded Contactor Compressor always runs	<ol style="list-style-type: none"> 1. Compressor contactor has failed closed 2. Thermostat demand signal not connected to module
Yellow "ALERT" Flash Code 9	Low Voltage Control circuit < 18VAC	<ol style="list-style-type: none"> 1. Control circuit transformer is overloaded 2. Low line voltage to compressor

569J*08G/H

Table 9 – CADM Troubleshooting

Miswired Module Indication	Recommended Troubleshooting Action
Green LED is not on, module does not power up	Determine if both R and C module terminals are connected. Verify voltage is present at module's R and C terminals. NOTE: The CADM requires a constant nominal 24VAC power supply. The wiring to the module's R and C terminals must be directly from the control transformer. The module cannot receive its power from another device that will interrupt the 24VAC power supply. See the 569J Wiring Diagram(s) (Fig. 20).
Green LED Intermittent, module powers up only when compressor runs	Determine if R and Y terminals are wired in reverse. Verify module's R and C terminals have a constant source. See "NOTE" above for details on R and C wiring.
TRIP LED is on but system and compressor check OK	Verify Y terminal is wired properly per the 569J wiring diagram (see Fig. 20). Verify voltage at contactor coil falls below 0.5VAC when off. Verify 24VAC is present across Y and C when thermostat demand signal is present. If not, R and C are reverse wired.
TRIP LED and ALERT LED flashing together	Verify R and C terminals are supplied with 19-28VAC.
ALERT Flash Code 3 (Compressor Short Cycling) displayed incorrectly	Verify Y terminal is connected to 24VAC at contactor coil. Verify voltage at contactor coil falls below 0.5VAC when off.
ALERT Flash Code 5 or 6 (Open Circuit, Missing Phase) displayed incorrectly	Check that compressor T1 and T3 wires are through module's current sensing holes. Verify Y terminal is connected to 24VAC at contactor coil. Verify voltage at contactor coil falls below 0.5VAC when off.
Alert Flash Code * (Welded Contactor) displayed incorrectly	Determine if module's Y terminal is connected. Verify Y terminal is connected to 24VAC at contactor coil. Verify 24VAC is present across Y and C when thermostat demand signal is present. If not, R and C are reverse wired. Verify voltage at contactor coil falls below 0.5VAC when off.

569J*08G/H

Compressor Protection

Compressor Overtemperature Protection (IP) —

A thermostat installed on the compressor motor winding reacts to excessively high winding temperatures and shuts off the compressor.

Crankcase Heater —

The heater minimizes absorption of liquid refrigerant by oil in the crankcase during brief or extended shutdown periods. The heater is wired to cycle with the compressor; the heater is off when compressor is running, and on when compressor is off.

The crankcase heater will operate as long as the power circuit is energized. The main disconnect must be on to energize the crankcase heater.

IMPORTANT: Never open any switch or disconnect that energizes the crankcase heater unless unit is being serviced or is to be shut down for a prolonged period. After a prolonged shutdown on a service job, energize the crankcase heater for 24 hours before starting the compressor.

Advanced Scroll Temperature Protection (ASTP) —

See "Advanced Scroll Temperature Protection (ASTP)" on page 17.

Low-Pressure Switch —

The 569J low-pressure switch is stem-mounted on the suction line. Switches are all fixed, non-adjustable type.

High-Pressure Switch —

The high-pressure switch is stem mounted on the discharge line. The switch is a fixed, non-adjustable type.

Outdoor Fans —

Each fan is supported by a formed-wire mount bolted to the fan deck and covered with a wire guard. Fan motors have permanently lubricated bearings.

1. Shut off unit power supply. Install lockout tag.
2. Remove outdoor fan assembly (grille, motor, and fan).
3. Loosen fan hub setscrews.
4. Adjust fan height as shown in Fig. 23.
5. Tighten setscrews to 84 in-lbs (949 N-cm).
6. Replace outdoor fan assembly.

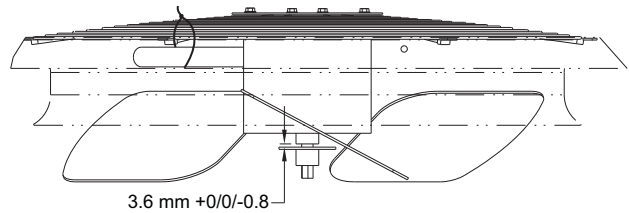

Fig. 23 - Outdoor Fan Blade Position

C10103

Lubrication —

Fan Motors: The fan motors have sealed bearings. No provisions are made for lubrication.

Compressor: The compressor has its own oil supply. Loss of oil due to a leak in the system should be the only reason for adding oil after the system has been in operation.

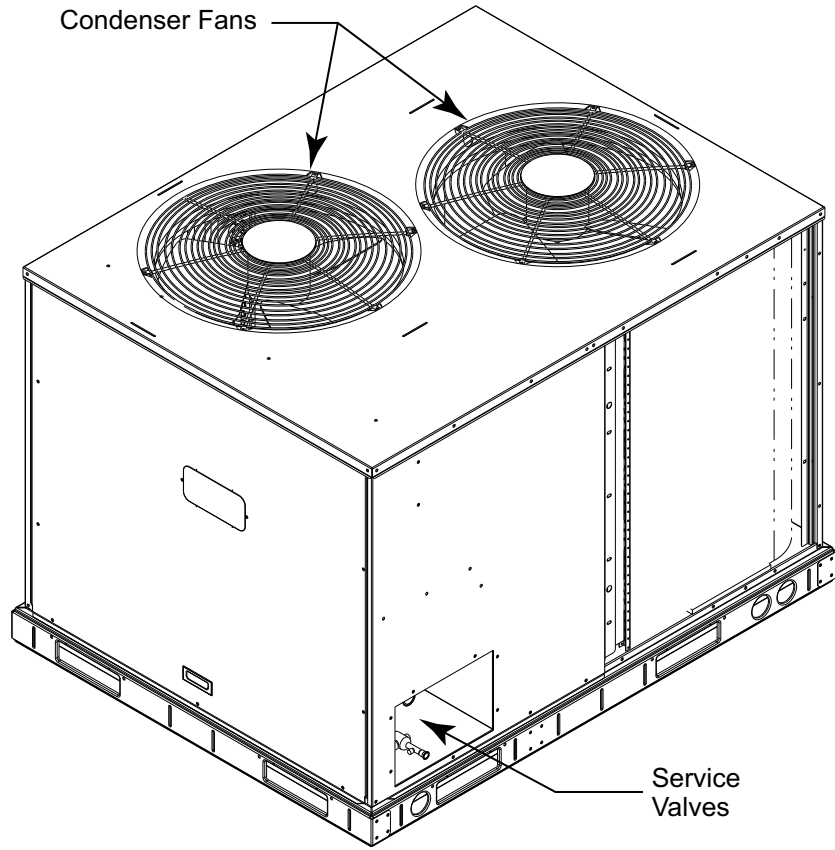

Fig. 24 - 569J*08G/H Exterior

C14295

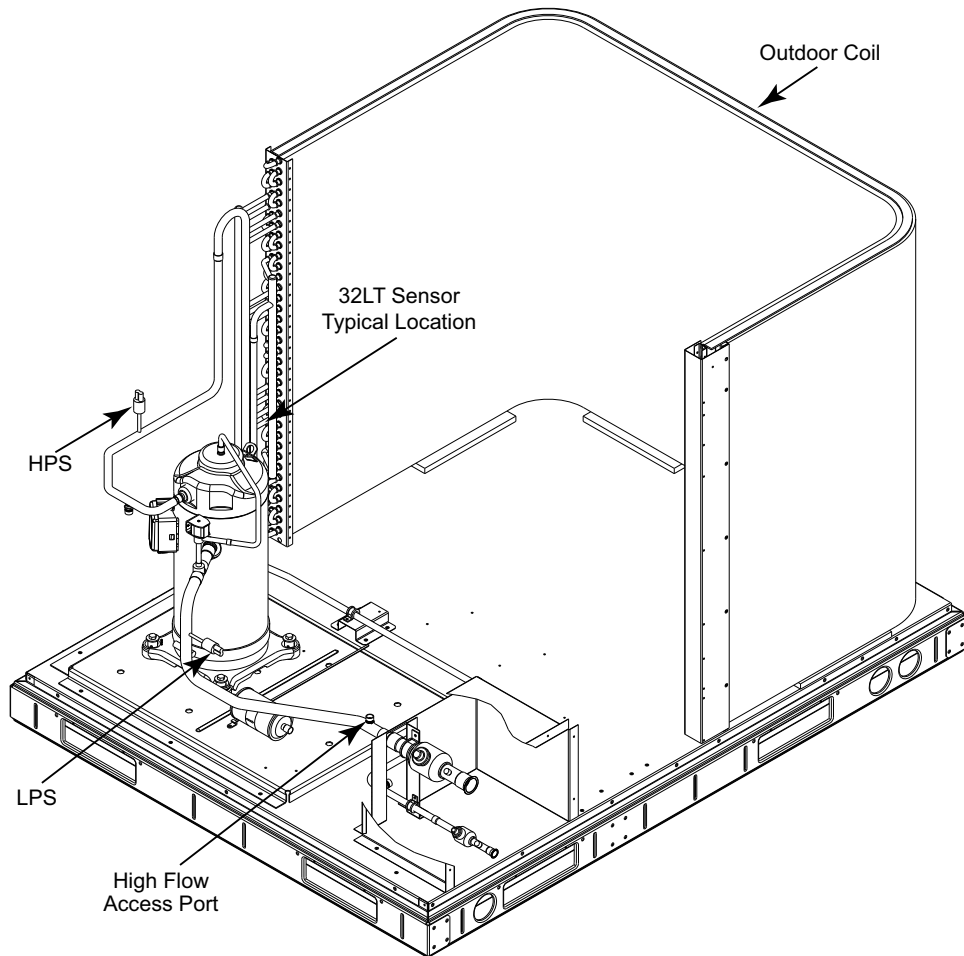

Fig. 25 - 569J*08G/H Interior

C14296

Routine Cleaning of Round-Tube Plate Fin Coils —

Periodic cleaning with Totaline® environmentally sound coil cleaner is essential to extend the life of RTPF coils. This cleaner is available as part number P902-0301 for a one gallon container, and part number P902-0305 for a 5 gallon container. It is recommended that all RTPF coils be cleaned with the Totaline environmentally sound coil cleaner as described below.

Coil cleaning should be part of the unit's regularly scheduled maintenance procedures to ensure long life of the coil. Failure to clean the coils may result in reduced durability in the environment.

Avoid the use of:

- coil brighteners
- acid cleaning prior to painting
- high pressure washers
- poor quality water for cleaning

Totaline environmentally sound coil cleaner is non-flammable, hypoallergenic, non-bacterial, and a USDA accepted biodegradable agent that will not harm the coil or surrounding components such as electrical wiring, painted metal surfaces, or insulation. Use of non-recommended coil cleaners is strongly discouraged since coil and unit durability could be affected.

Totaline Environmentally Sound Coil Cleaner Application Equipment —

- 2½ gallon garden sprayer
- water rinse with low velocity spray nozzle

⚠ CAUTION

UNIT DAMAGE HAZARD

Failure to follow this caution may result in corrosion and damage to the unit.

Harsh chemicals, household bleach or acid or basic cleaners should not be used to clean outdoor or indoor coils or any kind. These cleaners can be very difficult to rinse out of the coil and can accelerate corrosion at the fin/tube interface where dissimilar materials are in contact. If there is dirt below the surface of the coil use the Totaline environmentally sound coil cleaner as described above.

⚠ CAUTION

UNIT RELIABILITY HAZARD

Failure to follow this caution may result in reduced unit performance.

High velocity water from a pressure washer, garden hose, or compressed air should never be used to clean a coil. The force of the water or air jet will bend the fin edges and increase airside pressure drop.

Totaline Environmentally Sound Coil Cleaner Application Instructions:

NOTE: Proper eye protection such as safety glasses is recommended during mixing and application.

1. Turn off unit power.
2. Remove screws holding rear corner post and top cover in place. Pivot top cover up 12 to 18 inches (305 to 457 mm) and support with a rigid support. See Fig. 26.

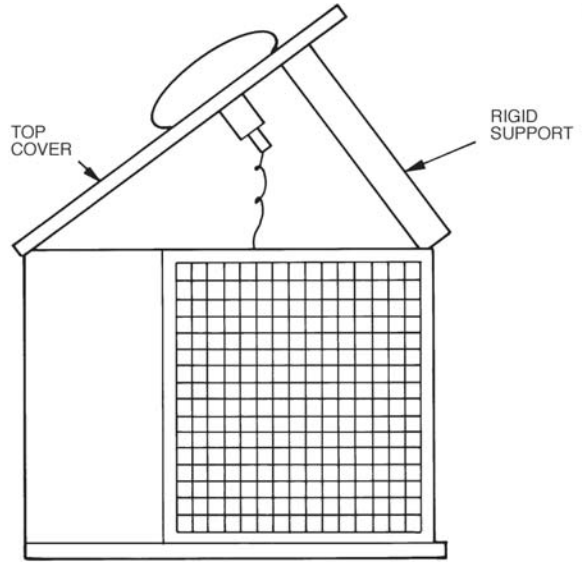

C10216

Fig. 26 - Pivot and Support Top Cover

3. Remove all surface loaded fibers and dirt with a vacuum cleaner. If a vacuum cleaner is not available, a soft non-metallic bristle brush may be used. In either case, the tool should be applied in the direction of the fins. Coil surfaces can be easily damaged (fin edges can be easily bent over and damage to the coating of a protected coil) if the tool is applied across the fins.

NOTE: Use of a water stream, such as a garden hose, against surface loaded coil will drive the fibers and dirt into the coil, making cleaning efforts more difficult. Surface loaded fibers must be completely removed prior to using low velocity clean water rinse.

4. Using a low velocity garden hose thoroughly wet finned surfaces with clean water. Be careful not to bend the fins.
5. Mix Totaline environmentally sound coil cleaner in a 2½ gallon garden sprayer according to the instructions included with the cleaner. The optimum solution temperature is 100°F (38°C).

NOTE: Do NOT USE water in excess of 130°F (54°C), as the enzymatic activity will be destroyed.

6. Thoroughly apply Totaline® environmentally sound coil cleaner solution to all coil surfaces including the finned area, tube sheets and coil headers.
7. Hold garden sprayer nozzle close to finned areas and apply cleaner with a vertical, up-and-down motion. Avoid spraying in horizontal pattern to minimize potential for fin damage.
8. Ensure cleaner thoroughly penetrates deep into finned areas.

9. Interior and exterior finned areas must be thoroughly cleaned.
10. Finned surfaces should remain wet with cleaning solution for 10 minutes.
11. Ensure surfaces are not allowed to dry before rinsing. Reapply cleaner as needed to ensure 10-minute saturation is achieved.
12. Thoroughly rinse all surfaces with low velocity clean water using downward rinsing motion of water spray nozzle. Protect fins from damage from the spray nozzle.
13. Replace top cover and rear corner posts.

FASTENER TORQUE VALUES

Table 10 – Torque Values

Compressor mounting bolts	65–75 in-lbs (734–847 N-cm)
Condenser fan motor mounting bolts	20 ±2 in-lbs (226 ±23 N-cm)
Condenser fan hub setscrew	84 ±2 in-lbs (949 ±136 N-cm)
High-flow service port	96 ±10 in-lbs (1085 ±23 N-cm)
Schrader-type service check valve	2–3 in-lbs (23–34 N-cm)
Compressor oil sightglass thread	330 ±31 in-lbs (23–34 N-cm)
Compressor to Compressor rail torque	120–168 in-lbs (1356–1898 N-cm)
Compressor rail to base pan torque	70 ±5 in-lbs (791 ±57 N-cm)

569J*08G/H

TROUBLESHOOTING

PROBLEM	SOLUTION
<p>COMPRESSOR DOES NOT RUN</p> <p><u>Contactors Open</u></p> <ol style="list-style-type: none"> 1. Power off. 2. Fuses blown in field power circuit. 3. No control power. 4. Thermostat circuit open. 5. Safety device lockout circuit active. 6. Low-pressure switch open. 7. High-pressure switch open. 8. Compressor overtemperature switch open. 9. Loose electrical connections. 10. Compressor stuck. <p><u>Contactors Closed</u></p> <ol style="list-style-type: none"> 1. Compressor leads loose. 2. Motor windings open. 3. Single phasing. 	<ol style="list-style-type: none"> 1. Restore power. 2. After finding cause and correcting, replace with correct size fuse. 3. Check control transformer primary connections and circuit breaker. 4. Check thermostat setting. 5. Reset lockout circuit. 6. Check for refrigerant undercharge, obstruction of indoor airflow. Make sure liquid line solenoid valve(s) is open. 7. Check for refrigerant overcharge, obstruction of outdoor airflow, air in system. Be sure outdoor fans are operating correctly. 8. Check for open condition. Allow for reset. Replace compressor if necessary. 9. Tighten all connections. 10. See compressor service literature. <ol style="list-style-type: none"> 1. Check connections. 2. See compressor service literature. 3. Check for blown fuse. Check for loose connection at compressor terminal.
<p>COMPRESSOR STOPS ON HIGH-PRESSURE SWITCH</p> <p><u>Outdoor Fan On</u></p> <ol style="list-style-type: none"> 1. High-pressure switch faulty. 2. Reversed fan rotation. 3. Airflow restricted. 4. Air recirculating. 5. Noncondensables in system. 6. Refrigerant overcharge. 7. Line voltage incorrect. 8. Refrigerant system restrictions. <p><u>Outdoor Fan Off</u></p> <ol style="list-style-type: none"> 1. Fan slips on shaft. 2. Motor not running. 3. Motor bearings stuck. 4. Motor overload open. 5. Motor burned out. 	<ol style="list-style-type: none"> 1. Replace switch. 2. Confirm rotation, correct if necessary. 3. Remove obstruction. 4. Clear airflow area. 5. Recover refrigerant and recharge as required. 6. Recover refrigerant as required. 7. Consult power company. 8. Check or replace filter drier, expansion valve, etc. <ol style="list-style-type: none"> 1. Tighten fan hub setscrews. 2. Check power and capacitor. 3. Replace bearings. 4. Check overload rating. Check for fan blade obstruction. 5. Replace motor.

TROUBLESHOOTING (cont)

PROBLEM	SOLUTION
<p>COMPRESSOR CYCLES ON LOW-PRESSURE SWITCH</p> <p><u>Indoor-Air Fan Running</u></p> <ol style="list-style-type: none"> Liquid line solenoid valve(s) fails to open. Filter drier plugged. Expansion valve power head defective. Low refrigerant charge. <p><u>Airflow Restricted</u></p> <ol style="list-style-type: none"> Coil iced up. Coil dirty. Air filters dirty. Dampers closed. <p><u>Indoor-Air Fan Stopped</u></p> <ol style="list-style-type: none"> Electrical connections loose. Fan relay defective. Motor overload open. Motor defective. Fan belt broken or slipping. 	<ol style="list-style-type: none"> Check liquid line solenoid valve(s) for proper operation. Replace if necessary. Replace filter drier. Replace power head. Add charge. Check low-pressure switch setting. <ol style="list-style-type: none"> Check refrigerant charge. Clean coil fins. Clean or replace filters. Check damper operation and position. <ol style="list-style-type: none"> Tighten all connections. Replace relay. Power supply. Replace motor. Replace or tighten belt.
<p>COMPRESSOR RUNNING BUT COOLING INSUFFICIENT</p> <p><u>Suction Pressure Low</u></p> <ol style="list-style-type: none"> Refrigerant charge low. Head pressure low. Air filters dirty. Expansion valve power head defective. Indoor coil partially iced. Indoor airflow restricted. <p><u>Suction Pressure High</u></p> <ol style="list-style-type: none"> Heat load excessive. 	<ol style="list-style-type: none"> Add refrigerant. Check refrigerant charge. Check outdoor-air fan thermostat settings. Clean or replace filters. Replace power head. Check low-pressure setting. Remove obstruction. <ol style="list-style-type: none"> Check for open doors or windows in vicinity of fan coil.
<p>UNIT OPERATES TOO LONG OR CONTINUOUSLY</p> <ol style="list-style-type: none"> Low refrigerant charge. Control contacts fused. Air in system. Partially plugged expansion valve or filter drier. 	<ol style="list-style-type: none"> Add refrigerant. Replace control. Purge and evacuate system. Clean or replace.
<p>SYSTEM IS NOISY</p> <ol style="list-style-type: none"> Piping vibration. Compressor noisy. 	<ol style="list-style-type: none"> Support piping as required. Replace compressor if bearings are worn.
<p>COMPRESSOR LOSES OIL</p> <ol style="list-style-type: none"> Leak in system. Crankcase heaters not energized during shutdown. Improper interconnecting piping design. 	<ol style="list-style-type: none"> Repair leak. Check wiring and relays. Check heater and replace if defective. Check piping for oil return. Replace if necessary.
<p>FROSTED SUCTION LINE</p> <p>Expansion valve admitting excess refrigerant.</p>	<p>Adjust expansion valve.</p>
<p>HOT LIQUID LINE</p> <ol style="list-style-type: none"> Shortage of refrigerant due to leak. Expansion valve opens too wide. 	<ol style="list-style-type: none"> Repair leak and recharge. Adjust expansion valve.
<p>FROSTED LIQUID LINE</p> <ol style="list-style-type: none"> Restricted filter drier. Liquid line solenoid valve partially closed. 	<ol style="list-style-type: none"> Remove restriction or replace. Replace valve.

569J*08G/H

APPENDIX A

Air Conditioner & Heat Pump with PURON® — Quick Reference Guide

- Puron® (R-410A) refrigerant operates at 50 percent to 70 percent higher pressures than R-22. Be sure that servicing equipment and replacement components are designed to operate with Puron®.
- Puron® refrigerant cylinders are rose colored.
- Recovery cylinder service pressure rating must be 400 psig, DOT 4BA400 or DOT BW400.
- Puron® systems should be charged with liquid refrigerant. Use a commercial type metering device in the manifold hose when charging into suction line with compressor operating.
- Manifold sets should be 700 psig high side and 180 psig low side with 550 psig low-side retard.
- Use hoses with 700 psig service pressure rating.
- Leak detectors should be designed to detect HFC refrigerant.
- Puron®, as with other HFCs, is only compatible with POE oils.
- Vacuum pumps will not remove moisture from oil.
- Use only factory specified liquid-line filter driers with rated working pressures greater than 600 psig.
- Do not install a suction-line filter drier in liquid-line.
- POE oils absorb moisture rapidly. Do not expose oil to atmosphere.
- POE oils may cause damage to certain plastics and roofing materials.
- Wrap all filter driers and service valves with wet cloth when brazing.
- A factory approved, liquid-line filter drier is required on every unit.
- Do not use an R-22 TXV.
- If indoor unit is equipped with a TXV, it must be changed to a Puron® TXV.
- Never open system to atmosphere while it is under a vacuum.
- When system must be opened for service, recover refrigerant, break vacuum with dry nitrogen before opening system.
- Always replace filter drier after opening system for service.
- Do not vent Puron® into the atmosphere.
- Do not use capillary tube coils.
- Observe all **warnings**, **cautions**, and **bold** text.
- All Puron® heat pumps must have indoor TXV.
- Do not leave Puron® suction line driers in place for more than 72 hours.

APPENDIX B

Wiring Diagram List

Unit	Electrical Characteristics	Diagram Number
569J*08G/H	208/230-3-60	38AU000026
	460-3-60	38AU000027
	575-3-60	38AU000025

APPENDIX C

Low Ambient Option — Factory Installed

569J*08H units with the factory installed low ambient option are equipped with a Motormaster® solid-state head pressure control which regulates fan speed. A temperature sensor mounted on the outdoor coil controls the speed of approved outdoor fan motors in order to maintain a constant head pressure in the outdoor coil (see Fig. 27). The control maintains the appropriate head pressure at low ambient temperatures down to -20°F (-28°C).

569J*08G/H

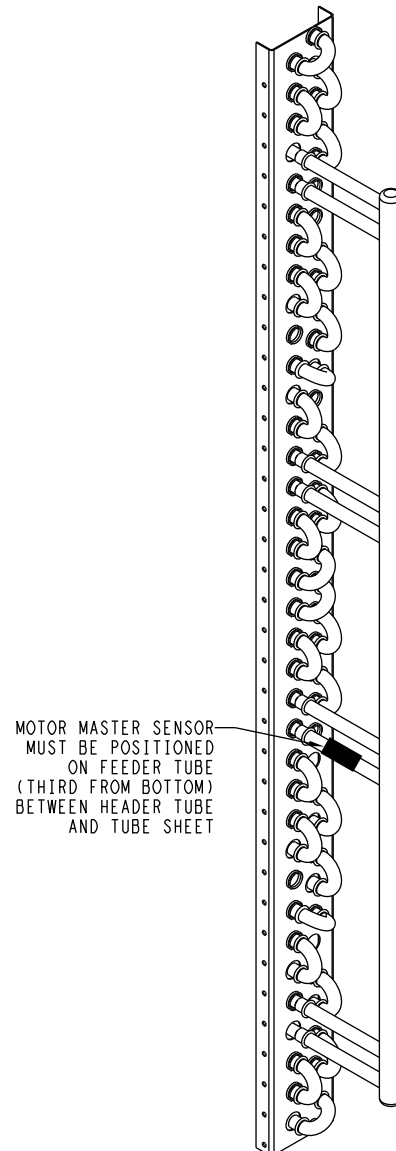

Fig. 27 - 569J*08H Motormaster Sensor Location

C14297

Wind baffles are required to prevent wind cross currents from causing abnormally low condensing temperatures.

Use 20-gauge sheet metal to fabricate wind baffles (see Fig. 28 and Table 11).

Operation —

Fan on/off control in cooling-only units is provided by an outdoor fan relay (OFR).

In cooling mode, fan motor speed of outdoor motors OFM1 and OFM3 is regulated by the speed control temperature sensor on outdoor coil 1 for a minimum coil condensing temperature of approximately 100°F (38°C) at higher outdoor ambient temperature and 80°F (27°C) at lower ambient. Additionally, outdoor fan motor OFM2 and OFM4 are turned on/off by the low ambient temperature switch, LAS, operating the low ambient relay (LAR). The LAS control temperatures are open 42°F +/- 5°F, close 57°F +/- 5°F (open 5.5°C +/- 2.8°C, close 13.9°C +/- 2.8°C).

To override the speed control for full fan speed operation during service or maintenance, either:

- a. remove sensor and place in hot water >120°F (>49°C), or
- b. rewire to bypass control by connecting speed control input and output power wires.

Troubleshooting —

OBSERVATION	POSSIBLE REMEDY
Fans won't start	All fans: Check power & wiring Check outdoor fan relay (OFR) OFM1, OFM3 only: Check speed control sensor location Check speed sensor resistance OFM2, OFM4 only: Check low ambient switch (LAS) Check low ambient relay (LAR)
Cooling – Center outdoor fans (OFM2, OFM4) off below approximately 60°F (16°C) outdoor ambient.	Normal operation
Cooling – Center outdoor fans (OFM2, OFM4) not on above approximately 60°F (16°C) outdoor ambient	Check low ambient switch (LAS) Check low ambient relay (LAR)
Cooling – Slow fan speed for outer fans (OFM1, OFM3) at start or during low outdoor ambient	Normal operation
Cooling – Slow fan speed for outer fans (OFM1, OFM3) above 85°F (29°F) outdoor ambient (should be full speed)	Check speed control sensor location Check speed control sensor resistance Check fan motor capacitor
Cooling – motor current into speed control is greater than motor name-plate FLA	Normal operation Up to 30% higher A at partial speed at low ambient

Speed Control Sensor Resistance —

TEMPERATURE		RESISTANCE
°F +/- 2°F°	°C +/- 1C	Ohms, nominal
-22	-30	88350
-4	-20	48485
14	-10	27650
32	0	16325
50	10	9950
68	20	6245
77	25	5000
86	30	4028
104	40	2663
122	50	1801
140	60	1244
158	70	876

0.85 (TYP)
0.47 (TYP)

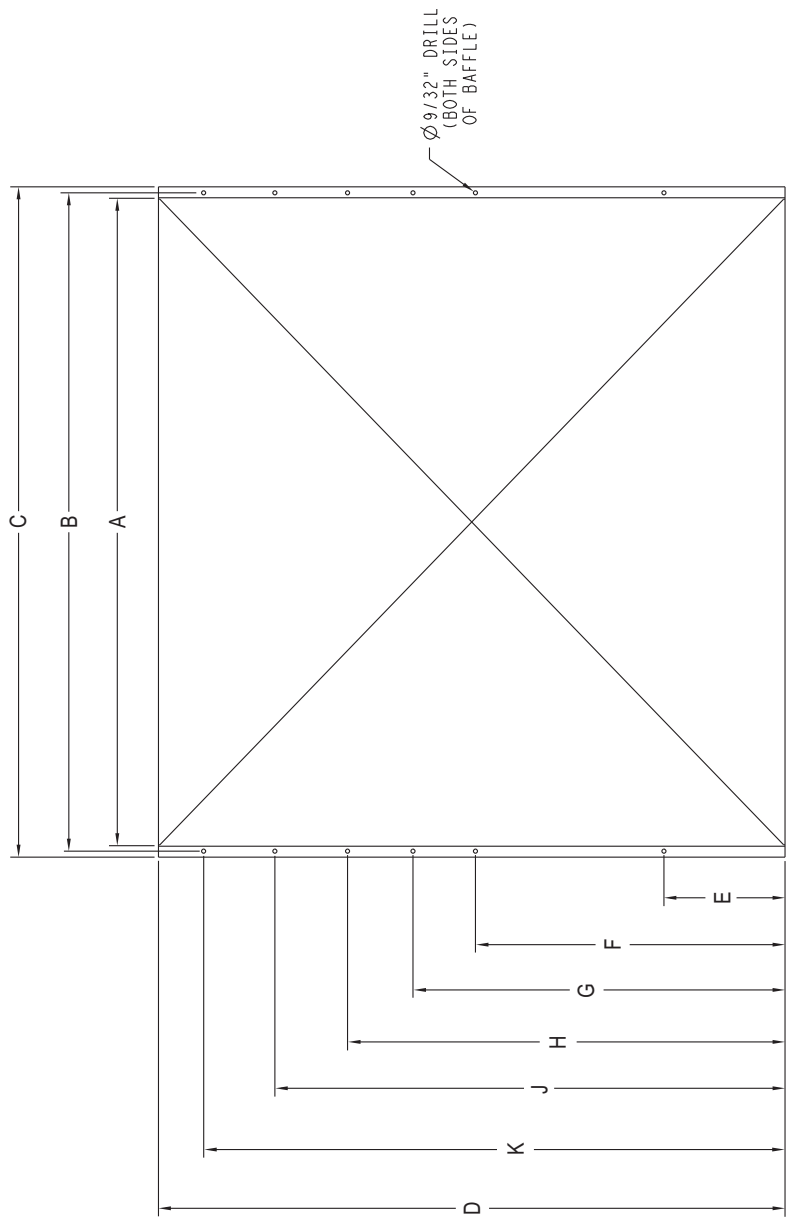
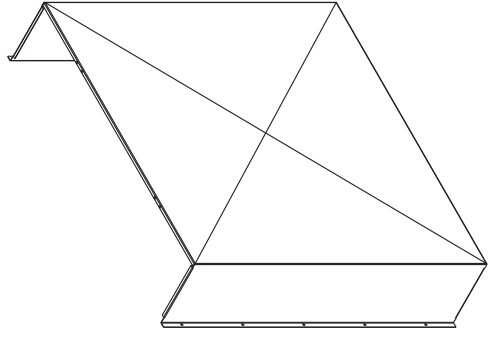
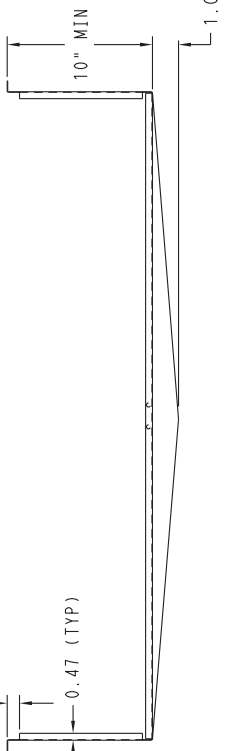

Fig. 28 - Wind Baffles

C10800

Table 11 – Wind Baffle Dimension

DIMENSIONS – INCHES											
UNIT	BAFFLE	A	B	C	D	E	F	G	H	J	K
569J*08H	LEFT SIDE	28 1/2	29	29 3/4	35 1/4	1 1/4	9 1/4	17 1/4	25 1/4	33 1/4	–
	BACK	40	40 3/4	41 1/2	35 1/4	4 1/4	11 1/4	18 1/4	25 1/4	32 1/4	–
	RIGHT SIDE	25	25 1/2	26 1/4	35 1/4	4 1/4	11 1/4	18 1/4	25 1/4	32 1/4	–

DIMENSIONS – MM											
UNIT	BAFFLE	A	B	C	D	E	F	G	H	J	K
569J*08H	LEFT SIDE	718	737	756	895	33	236	439	643	846	–
	BACK	1016	1035	1054	895	107	284	462	640	818	–
	RIGHT SIDE	629	648	667	895	107	284	462	640	818	–

569J*08G/H

START-UP CHECKLIST

I. PRELIMINARY INFORMATION

OUTDOOR: MODEL NO. _____ SERIAL NO. _____

INDOOR: AIRHANDLER MANUFACTURER _____

MODEL NO. _____ SERIAL NO. _____

ADDITIONAL ACCESSORIES _____

II. PRE-START-UP

OUTDOOR UNIT

IS THERE ANY SHIPPING DAMAGE? (Y/N) _____

IF SO, WHERE: _____

WILL THIS DAMAGE PREVENT UNIT START-UP? (Y/N) _____

CHECK POWER SUPPLY. DOES IT AGREE WITH UNIT? (Y/N) _____

HAS THE GROUND WIRE BEEN CONNECTED? (Y/N) _____

HAS THE CIRCUIT PROTECTION BEEN SIZED AND INSTALLED PROPERLY? (Y/N) _____

ARE THE POWER WIRES TO THE UNIT SIZED AND INSTALLED PROPERLY? (Y/N) _____

CONTROLS

ARE THERMOSTAT AND INDOOR FAN CONTROL WIRING CONNECTIONS MADE AND CHECKED?
(Y/N) _____

ARE ALL WIRING TERMINALS (including main power supply) TIGHT? (Y/N) _____

HAS CRANKCASE HEATER BEEN ENERGIZED FOR 24 HOURS? (Y/N) _____

INDOOR UNIT

HAS WATER BEEN PLACED IN DRAIN PAN TO CONFIRM PROPER DRAINAGE? (Y/N) _____

ARE PROPER AIR FILTERS IN PLACE? (Y/N) _____

HAVE FAN AND MOTOR PULLEYS BEEN CHECKED FOR PROPER ALIGNMENT? (Y/N) _____

DO THE FAN BELTS HAVE PROPER TENSION? (Y/N) _____

HAS CORRECT FAN ROTATION BEEN CONFIRMED? (Y/N) _____

PIPING

ARE LIQUID LINE SOLENOID VALVES LOCATED AT THE INDOOR COILS AS REQUIRED? (Y/N) _____

HAVE LEAK CHECKS BEEN MADE AT COMPRESSOR, OUTDOOR AND INDOOR COILS,
TXVs (Thermostatic Expansion Valves), SOLENOID VALVES, FILTER DRIERS, AND FUSIBLE PLUGS
WITH A LEAK DETECTOR? (Y/N) _____

LOCATE, REPAIR, AND REPORT ANY LEAKS. _____

HAVE LIQUID LINE SERVICE VALVES BEEN OPENED? (Y/N) _____

HAVE SUCTION LINE SERVICE VALVES BEEN OPENED? (Y/N) _____

569J*08G/H

