

**38MA\*R**  
**Outdoor Unit Single Zone Ductless System**  
**Sizes 09 to 36**

# Installation Instructions



**Fig. 1 —Sizes 09K to 36K**

## TABLE OF CONTENTS

SAFETY CONSIDERATIONS.....	2
PARTS LIST .....	3
SYSTEM REQUIREMENTS.....	4
WIRING .....	5
DIMENSIONS.....	6
CLEARANCES .....	9
INSTALLATION TIPS .....	10
ELECTRICAL DATA.....	12
CONNECTION DIAGRAMS .....	12
SYSTEM VACUUM AND CHARGE.....	13
START-UP .....	14
TROUBLESHOOTING .....	14

**NOTE: Read the entire instruction manual before starting the installation.**

**NOTE: Images are for illustration purposes only. Actual models may differ slightly.**

## SAFETY CONSIDERATIONS

Installing, starting up, and servicing air- conditioning equipment can be hazardous due to system pressures, electrical components, and equipment location (roofs, elevated structures, etc.).

Only trained, qualified installers and service mechanics should install, start- up, and service this equipment.

Untrained personnel can perform basic maintenance functions such as coil cleaning. All other operations should be performed by trained service personnel only.

When working on the equipment, observe the precautions in the literature and on tags, stickers, and labels attached to the equipment.

Follow all safety codes. Wear safety glasses and work gloves. Keep a quenching cloth and a fire extinguisher nearby when brazing.

Use care in handling, rigging, and setting bulky equipment.

Read these instructions thoroughly and follow all warnings or cautions included in literature and attached to the unit. Consult local building codes and National Electrical Code (NEC) for special requirements. Recognize safety information.

This is the safety- alert symbol . When you see this symbol on the unit and in instructions or manuals, be alert to the potential for personal injury. Understand these signal words: **DANGER**, **WARNING**, and **CAUTION**. These words are used with the safety- alert symbol. **DANGER** identifies the most serious hazards which will result in severe personal injury or death. **WARNING** signifies hazards which could result in personal injury or death.

**CAUTION** is used to identify unsafe practices which may result in minor personal injury or product and property damage.

**NOTE** is used to highlight suggestions which will result in enhanced installation, reliability, or operation.



## WARNING

### ELECTRICAL SHOCK HAZARD

Failure to follow this warning could result in personal injury or death.

Before installing, modifying, or servicing system, main electrical disconnect switch must be in the OFF position. There may be more than 1 disconnect switch. Lock out and tag switch with a suitable warning label.



## WARNING



### EXPLOSION HAZARD

Failure to follow this warning could result in death, serious personal injury, and/or property damage.

Never use air or gases containing oxygen for leak testing or operating refrigerant compressors. Pressurized mixtures of air or gases containing oxygen can lead to an explosion.



## CAUTION

### EQUIPMENT DAMAGE HAZARD

Failure to follow this caution may result in equipment damage or improper operation.

Do not bury more than 36 in. (914 mm) of refrigerant pipe in the ground. If any section of pipe is buried, there must be a 6 in. (152 mm) vertical rise to the valve connections on the outdoor units. If more than the recommended length is buried, refrigerant may migrate to the cooler buried section during extended periods of system shutdown. This causes refrigerant slugging and could possibly damage the compressor at start-up.

# PARTS LIST

**Table 1 —Parts List**

PART NO.	PART NAME	QTY.
1	Outdoor unit	1
-	Literature package including installation instructions and warranty	1
-	Grommet to secure the outdoor unit (helps with vibration prevention during unit operation)	4
-	Drain Joint	1
-	Drain Hose	1

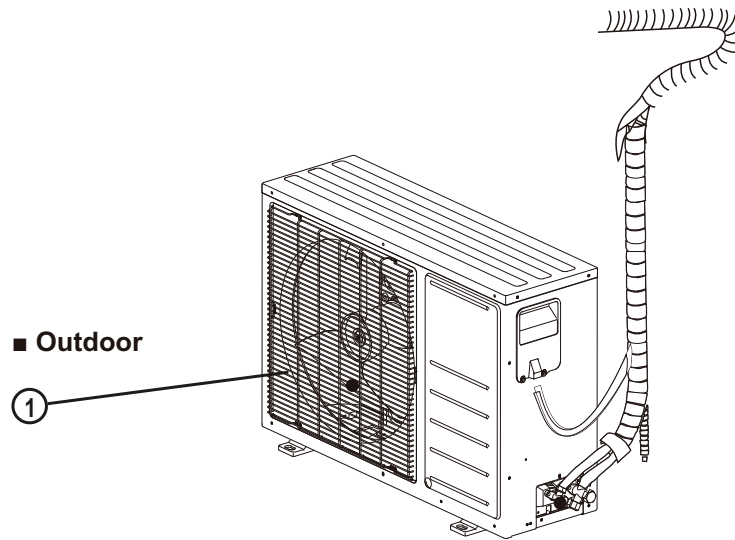

**Fig. 2 —Parts List**

**NOTE:**

- If the outdoor unit is higher than the indoor unit, prevent rain from flowing into the indoor unit along the connection pipe by making a downward arc in the connection pipe before it enters the wall to the indoor unit. This ensures that rain drips from the connection pipe before it enters the wall.
- Piping and the interconnecting wiring are field supplied.
- Figure 2 is only a sketch. Actual model may be slightly different.

Table 2 lists the units covered in this document.

**Table 2 — Unit Sizes**

SYSTEM TONS	KBTUH	VOLTAGE - PHASE	OUTDOOR MODEL
1.00	12,000	115-1	38MAQB12R--1
0.75	9,000	208/230-1	38MAQB09R--3
1.00	12,000	208/230-1	38MAQB12R--3
1.50	18,000	208/230-1	38MAQB18R--3
2.00	24,000	208/230-1	38MAQB24R--3
2.50	30,000	208/230-1	38MAQB30R--3
3.00	36,000	208/230-1	38MAQB36R--3

# SYSTEM REQUIREMENTS

Allow sufficient space for airflow and service of the unit. See Fig. 7 for the required minimum distances between the unit, walls or ceilings.

## Piping

**IMPORTANT: Both refrigerant lines must be insulated separately.**

Table 3 contains piping information for the product covered within this document.

**Table 3 — Piping and Refrigerant Information**

38MAR SIZE			12K (115V)	9K (208/230V)	12 (208/230V)	18K (208/230V)	24K (208/230V)	30K (208/230V)	36K (208/230V)
Piping	Min. Piping Length	Ft (m)	10 (3)	10 (3)	10 (3)	10 (3)	10 (3)	10 (3)	10 (3)
	Standard Piping Length	Ft (m)	25 (7.5)	25 (7.5)	25 (7.5)	25 (7.5)	25 (7.5)	25 (7.5)	25 (7.5)
	Max. Outdoor indoor height difference	Ft (m)	32 (10)	32 (10)	32 (10)	65 (20)	65 (20)	82 (25)	82 (25)
	Max. Piping Length with no additional refrigerant charge	Ft (m)	26 (8)	26 (8)	26 (8)	26 (8)	26 (8)	26 (8)	26 (8)
	Max. Piping Length	Ft (m)	82 (25)	82 (25)	82 (25)	98 (30)	164 (50)	164 (50)	164 (50)
	Additional refrigerant charge (between Standard – Max piping length)	Oz/ft (g/m)	0.16 (15)	0.16 (15)	0.16 (15)	0.16 (15)	0.32 (30)	0.32 (30)	0.32 (30)
	Gas Pipe	in	1/2	3/8	1/2	1/2	5/8	5/8	5/8
		(mm)	12.7	9.52	12.7	12.7	16	16	16
Liquid Pipe	in	1/4	1/4	1/4	1/4	3/8	3/8	3/8	
	(mm)	6.35	6.35	6.35	6.35	9.52	9.52	9.52	
Refrigerant	Refrigerant Type	-	R410A	R410A	R410A	R410A	R410A	R410A	R410A
	Heat Pump Models Charge Amount	Lbs (kg)	2.76 (125)	3.31 (1.5)	3.31 (1.5)	4.30 (1.95)	5.73 (2.60)	6.06 (2.75)	7.50 (3.40)

All outdoor units have an electronic expansion valve to manage the refrigerant flow of the fan coil connected.

## WIRING

All wires must be sized per NEC (National Electrical Code) or CEC (Canadian Electrical Code) and local codes. Use Electrical Data table MCA (minimum circuit amps) and MOCP (maximum over current protection) to correctly size the wires and the disconnect fuse or breakers respectively.

### **Recommended Connection Method for Power and Communication Wiring:**

The main power is supplied to the outdoor unit. The field supplied 14/3 stranded wire with ground with a 600 volt insulation rating, power/communication wiring from the outdoor unit to indoor unit consists of four (4) wires and provides the power for the indoor unit. Two wires are line voltage AC power, one is communication wiring (S) and the other is a ground wire. Wiring between indoor and outdoor unit is polarity sensitive. The use of BX wire is NOT recommended.

If installed in a high Electromagnetic field (EMF) area and communication issues exists, a 14/2 stranded shielded wire can be used to replace L2/N and (S) between outdoor unit and indoor unit landing the shield onto ground in the outdoor unit only.



## WARNING

### **EQUIPMENT DAMAGE HAZARD**

Failure to follow this caution may result in equipment damage or improper operation.

Wires should be sized based on NEC and local codes.



## CAUTION

### **EQUIPMENT DAMAGE HAZARD**

Failure to follow this caution may result in equipment damage or improper operation.

Be sure to comply with local codes while running wire from the indoor unit to the outdoor unit.

Every wire must be connected firmly. Loose wiring may cause the terminal to overheat or result in unit malfunction. A fire hazard may also exist. Ensure all wiring is tightly connected.

No wire should touch the refrigerant tubing, compressor or any moving parts.

Disconnecting means must be provided and shall be located within sight and readily accessible from the air conditioner.

Connecting cable with conduit shall be routed through the hole in the conduit panel.

**NOTE: Match with Multi-Family Fan Coils requires separate power for the indoor and outdoor unit. A 24V interface kit is required for compatibility. Refer to the 24V Interface Kit Installation Manual.**

# DIMENSIONS

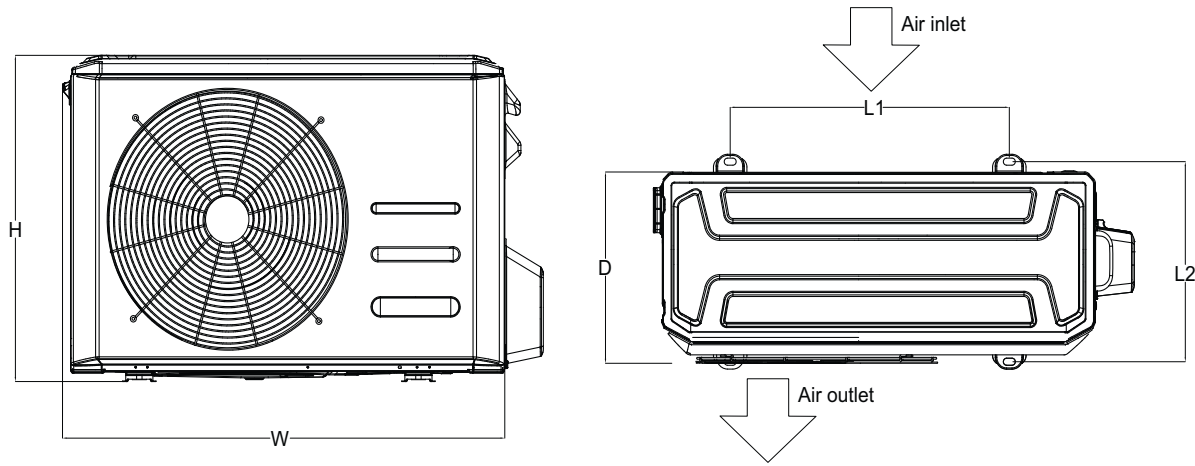

**Fig. 3 — Outdoor Unit**

**Table 4 — Outdoor Unit**

UNIT SIZE		12K	9K	12K	18K	24K	30K	36K
<b>VOLTAGE</b>		115V	208/230V	208/230V	208/230V	208/230V	208/230V	208/230V
<b>HEIGHT (H)</b>	<b>IN (MM)</b>	21.81 (554)	21.81 (554)	21.81 (554)	27.63 (702)	31.89 (810)	31.89 (810)	31.89 (810)
<b>WIDTH (W)</b>	<b>IN (MM)</b>	32.09 (815)	32.09 (815)	32.09 (815)	33.66 (855)	37.24 (946)	37.24 (946)	37.24 (946)
<b>DEPTH (D)</b>	<b>IN (MM)</b>	13.11 (333)	13.11 (333)	13.11 (333)	14.17 (360)	16.14 (410)	16.14 (410)	16.14 (410)
<b>L1</b>	<b>IN (MM)</b>	20.24 (514)	20.24 (514)	20.24 (514)	21.26 (540)	26.50 (673)	26.50 (673)	26.50 (673)
<b>L2</b>	<b>IN (MM)</b>	13.39 (340)	13.39 (340)	13.39 (340)	13.78 (350)	15.87(403)	15.87(403)	15.87 (403)
<b>OPERATING WEIGHT</b>	<b>LBS (KG)</b>	82.9 (37.6)	91.5 (41.5)	91.5 (41.5)	118.2 (53.6)	145.5 (66)	139.8 (63.4)	147.3 (66.8)

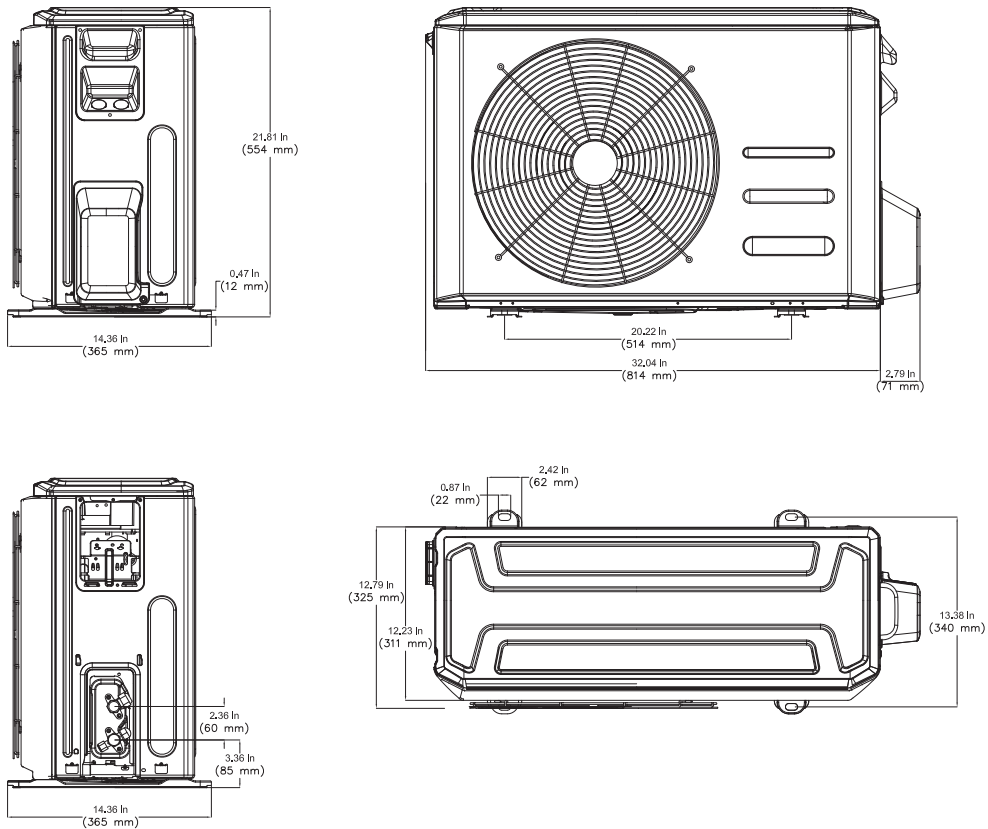

**Fig. 4 — Sizes 09K-12K**

# DIMENSIONS (CONT)

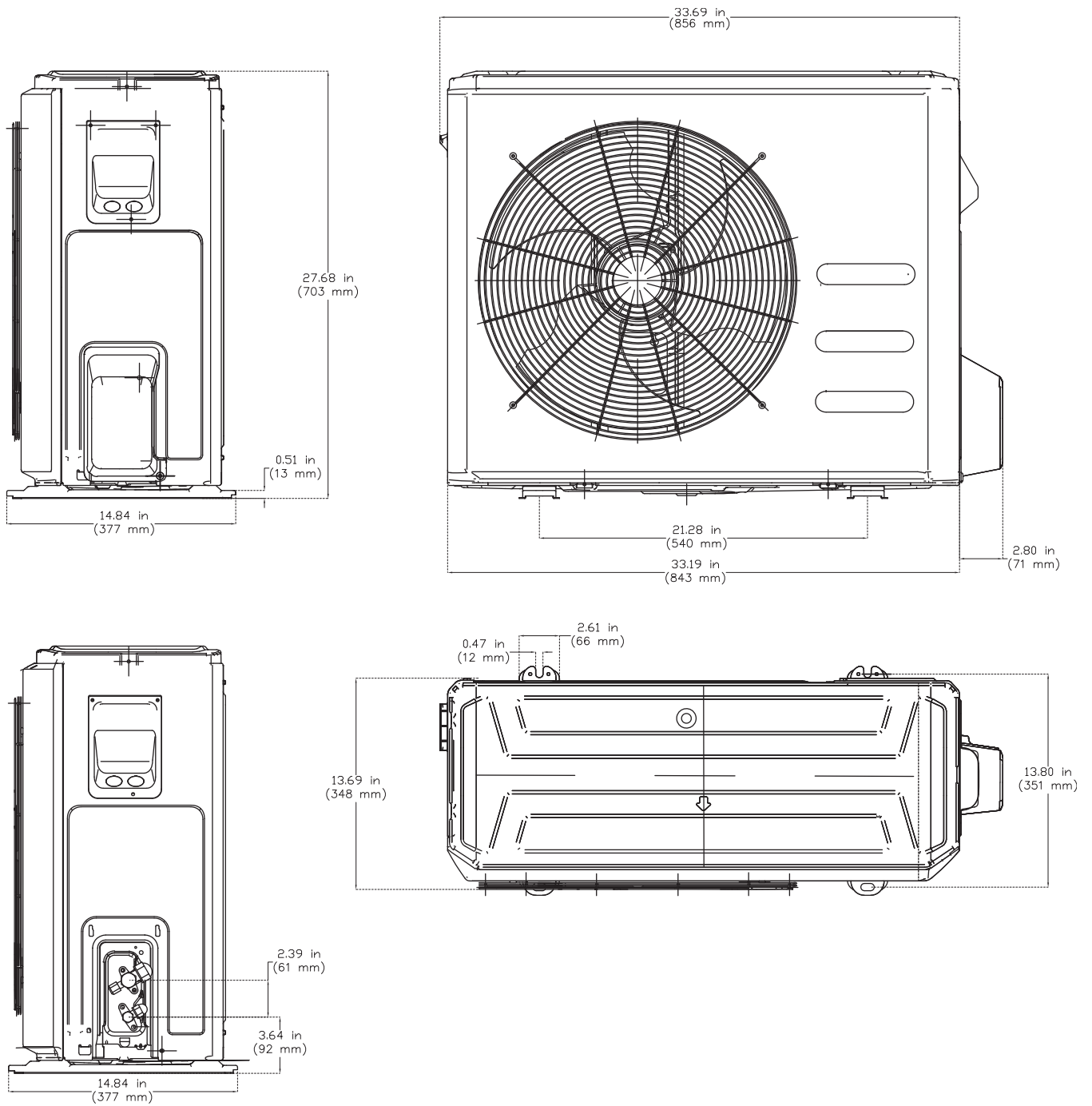

**Fig. 5 — Size 18K**

# DIMENSIONS (CONT)

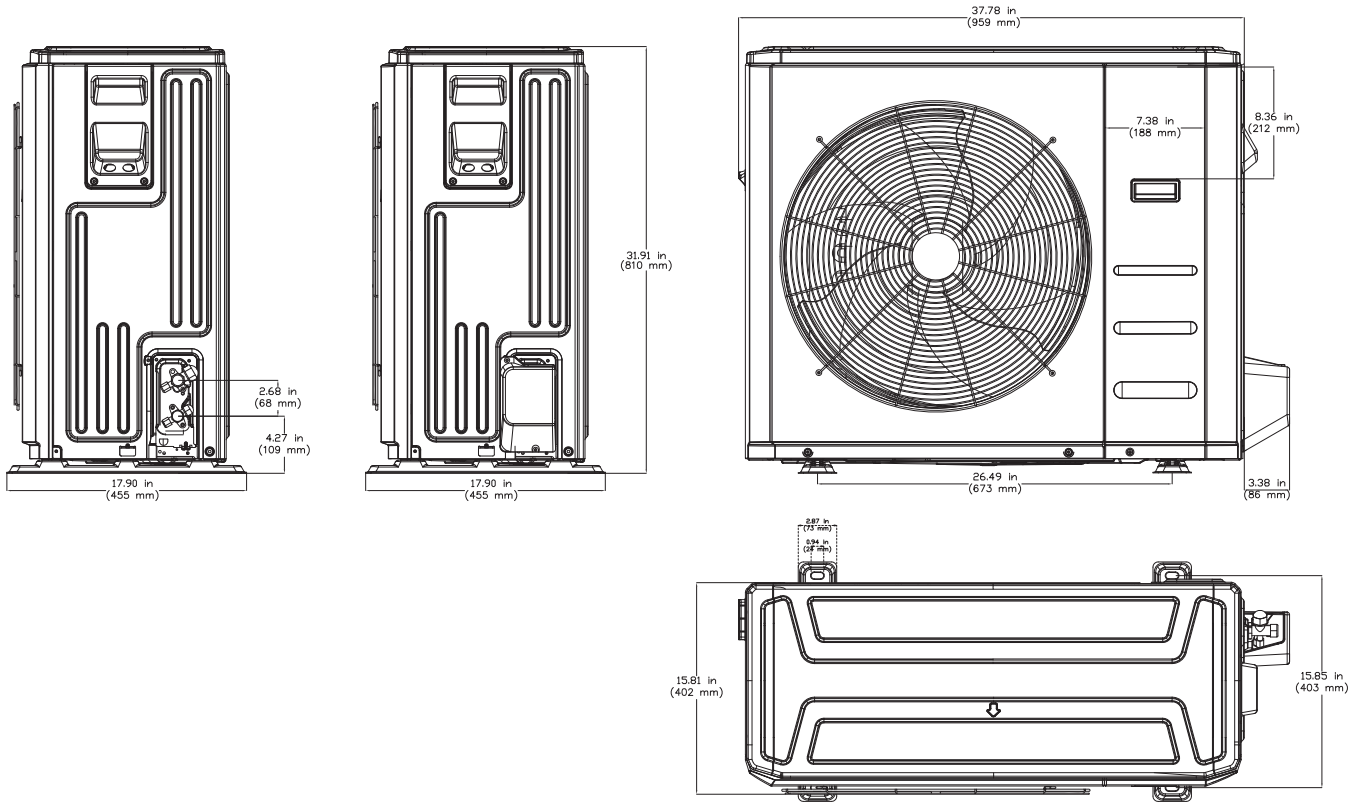
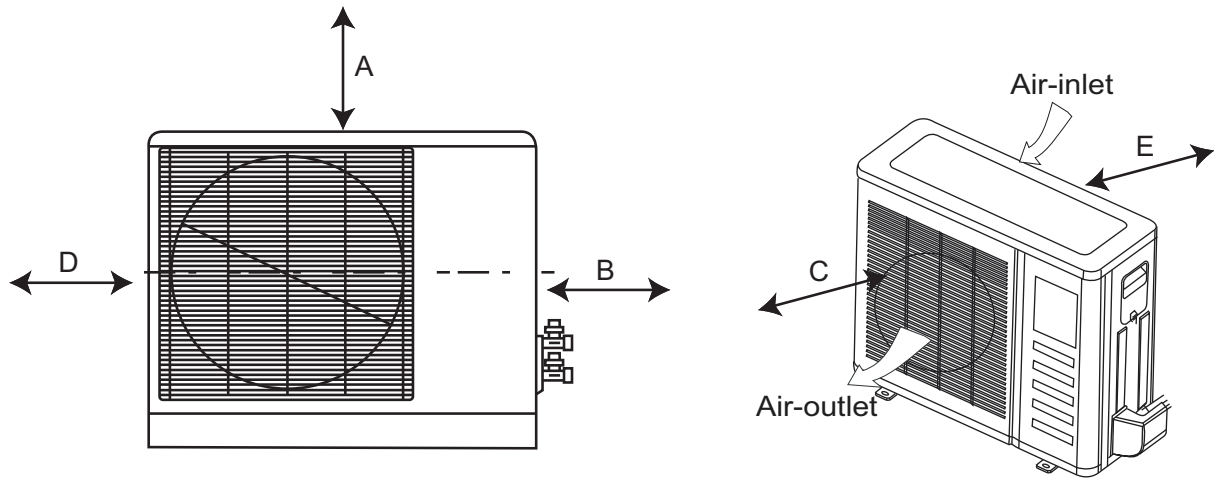

Fig. 6 — Sizes 24K, 30K, and 36K



# CLEARANCES



**Fig. 7 — Clearances**

**Table 5 — Clearance Dimensions**

UNIT	MINIMUM VALUE IN. (MM)
A	24 (610)
B	24 (610)
C	24 (610)
D	4 (101)
E	4 (101)

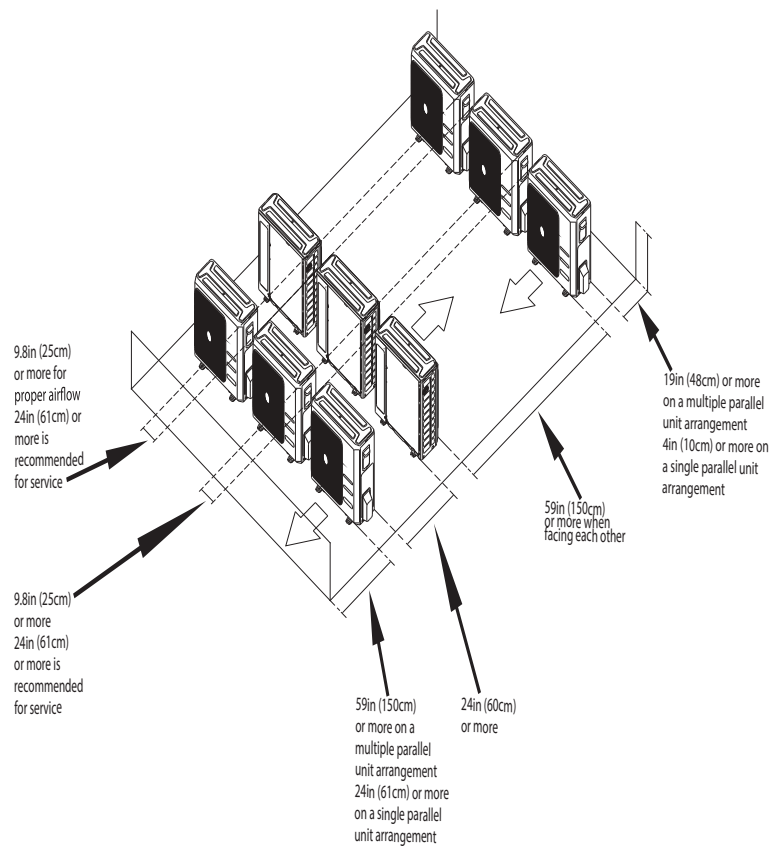

**Fig. 8 — Clearances for multiple units**

# INSTALLATION TIPS

## Ideal installation locations include:

### Outdoor Unit

- A location which is convenient to installation and not exposed to strong winds.
- A location which can bear the weight of the outdoor unit and where the outdoor unit can be mounted in a level position.
- A location which provides appropriate clearances (see Fig. 7).
- Do not install the indoor or outdoor units in a location with special environmental conditions. For those applications, contact your Ductless representative.

## OUTDOOR UNIT INSTALLATION

1. Use a rigid base to support the unit in a level position.
2. Locate the outdoor unit and connect piping and wiring.

**CAUTION**

**EQUIPMENT DAMAGE HAZARD**

Failure to follow this caution may result in equipment damage or improper operation.

In regions with snowfall and cold temperatures, avoid installing the outdoor unit in areas where it can be covered by snow. If the outdoor unit is installed in areas where heavy snow is expected, a field supplied ice or snow stand and/or field supplied-installed wind baffle should be installed to protect the unit from snow accumulation and/or blocked air intake. Blocking the air intake may result in reduced airflow, significantly reduced performance and damage to the equipment.

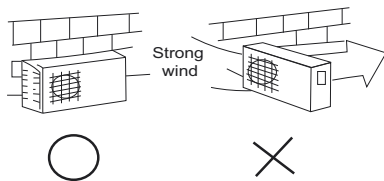

**Fig. 9 —High Wind Installation**

## MAKE REFRIGERANT PIPING CONNECTIONS (OUTDOOR UNIT)

**IMPORTANT: Use refrigeration grade tubing ONLY. No other type of tubing may be used. Use of other types of tubing will void the manufacturer's warranty.**

Do not open the service valves or remove the protective caps from the tubing ends until all connections are made.

Bend the tubing with bending tools to avoid kinks and flat spots.

Keep the tubing free of dirt, sand, moisture, and other contaminants to avoid damaging the refrigerant system.

Avoid sags in the suction line to prevent the formation of oil traps. Insulate each tube with a minimum 3/8-in. (10 mm) wall thermal pipe insulation. Inserting the tubing into the insulation before making the connections will save time and improve installation quality.

1. Remove the service valve cover, if provided with the unit.
2. Cut the pipe, with a pipe cutter, at 90 degrees (see Fig. 10).
3. Remove the service connection, if provided with the unit.

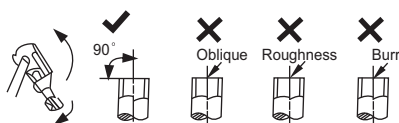
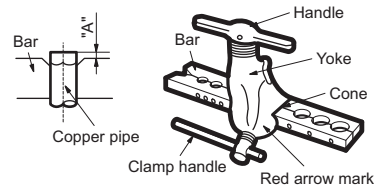

**Fig. 10 —Cut the pipe**

4. Remove all the burrs from the cut cross section of the pipe avoiding any burrs inside the tubes.
5. Remove the flare nuts attached to the indoor and outdoor units.
6. Install the correct size flare nut onto the tubing and make a flare connection. Refer to Table 6 for the flare nut spaces.

**Table 6 — Flare Nut Spacing**

OUTER DIAM. (MM)	A (MM)	
	MAX.	MIN.
Ø1/4"(6.35)	0.05 (1.3)	0.03 (0.7)
Ø3/8"(9.52)	0.06 (1.6)	0.04 (1.0)
Ø1/2"(12.7)	0.07 (1.8)	0.04 (1.0)
Ø5/8"(15.88)	0.09 (2.2)	0.08 (2.0)



**Fig. 11 —Flare Nut Spacing**

7. Apply a small amount of refrigerant oil to the flare connection on the tubing.
8. Align the center of the pipes and/or service valve.

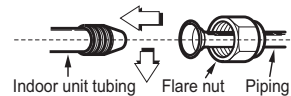
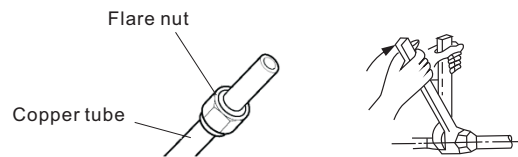

**Fig. 12 —Align Pipe Center**

9. Connect both the liquid and gas piping to the indoor unit.
10. Tighten the flare nut using a torque wrench as specified in Table 7.
11. Complete the installation.

**Table 7 — Tightening Torque**

PIPE DIAMETER INCH (MM)	TIGHTENING TORQUE	
	FT - LB	N - M
Ø1/4" (6.35)	10 to 13	13.6 to 17.6
Ø3/8" (9.52)	24 to 31	32.5 to 42.0
Ø1/2" (12.7)	37 to 46	50.1 to 62.3
Ø5/8" (15.88)	50 to 60	67.7 to 81.3



**Fig. 13 —Tighten the Flare Nut**

**CAUTION**

**EQUIPMENT DAMAGE HAZARD**

Failure to follow this caution may result in equipment damage or improper operation.

Excessive torque can break the flare nut depending on installation conditions.

## Install All Power and Interconnecting Wiring to Outdoor Units

1. Mount the outdoor power disconnect.
2. Run the power wiring from the main box to disconnect per NEC and local codes.
3. Remove the field wiring cover from the unit by loosening the screws.
4. Remove the caps on the conduit panel.
5. Connect the conduit to conduit panel (see Fig.14).
6. Properly connect both the power supply and control lines to the terminal block per the connection diagram for the appropriate unit capacity and voltage.
7. Ground the unit in accordance with NEC and local electrical codes.
8. Use the lock nuts to secure the conduit.
9. Reinstall the field wiring cover.

**CAUTION**

**EQUIPMENT DAMAGE HAZARD**

Failure to follow this caution may result in equipment damage or improper operation.

Be sure to comply with local codes while running wire from indoor unit to outdoor unit.

Every wire must be connected firmly. Loose wiring may cause the terminal to overheat or result in unit malfunction. A fire hazard may also exist. Therefore, ensure all wiring is tightly connected.

No wire should be allowed to touch the refrigerant tubing, compressor or any moving parts.

Disconnecting means must be provided and shall be located within sight and readily accessible from the air conditioner.

Connecting cable with the conduit shall be routed through hole in the conduit panel.

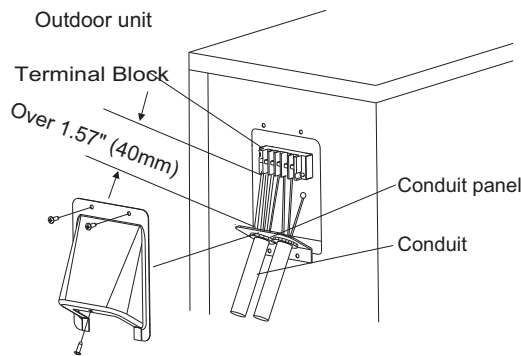

**Fig. 14 —Field Wiring**

## Drain Connections

Install drains must meet local sanitation codes.

### Install the outdoor unit drain joint

Fit the seal into the drain joint, then insert the drain joint into the base pan hole of the outdoor unit. Rotate 90° to securely assemble them. Connect the drain joint with an extension drain hose to avoid condensate from draining off the outdoor unit during the heating mode.

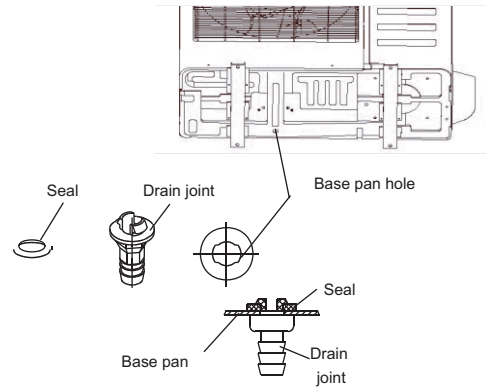

**Fig. 15 —Drain Joint**

**NOTE: Images are for illustration purposes only.**

**CAUTION**

**EQUIPMENT DAMAGE HAZARD**

In cold climates, ensure the drain hose is as vertical as possible to ensure swift water drainage. If water drains too slowly, it can freeze in the hose and flood the unit.

**NOTE: Basepan built-in with multiple holes for proper draining during defrost. For applications where it is required to seal these holes, and re-direct the condensate drain, rubber plugs are available through RCD.**

**Table 8 — Base Pan Base Rubber Plugs**

OUTDOOR UNIT MODEL NUMBER PER UNIT	BASE PAN BASE RUBBER PLUGS RCD PART NUMBER	QUANTITY
38MAQB12R--1 38MAQB09R--3 38MAQB12R--3	12600801A00077	13
38MAQB18R--3	12600801A00077	25
38MAQB24R--3 38MAQB30R--3 38MAQB36R--3	12600801A00117	5

# ELECTRICAL DATA

**Table 9 — Electrical Data**

MAR OUTDOOR UNIT SIZE		12K	9K	12K	18K	24K	30K	36K
Power Supply	Volts-PH-Hz	115-1-60	208/230-1-60	208/230-1-60	208/230-1-60	208/230-1-60	208/230-1-60	208/230-1-60
	Max – Min* Oper. Voltage	126-104	253-187	253-187	253-187	253-187	253-187	253-187
	MCA	15	9	9	18	20	20	25
	Max Fuse/ CB AMP	20	15	15	25	30	30	35
Compressor	Volts-PH-Hz	115-1-60	208/230-1-60	208/230-1-60	208/230-1-60	208/230-1-60	208/230-1-60	208/230-1-60
	RLA	9	5.25	5.65	12.3	14	15	17
Outdoor Fan Motor	Volts-PH-Hz	115-1-60	208/230-1-60	208/230-1-60	208/230-1-60	208/230-1-60	208/230-1-60	208/230-1-60
	FLA	0.6	0.38	0.38	0.42	0.5	0.6	0.6
	Rated HP	0.053	0.053	0.053	0.067	0.16	0.16	0.16
	Output	40	40	40	50	120	120	120

\*Permissible limits of the voltage range at which the unit will operate satisfactorily.

**LEGEND**

- FLA - Full Load Amps
- MCA - Minimum Circuit Amps
- MOCP - Maximum Over-Current Protection
- RLA - Rated Load Amps

## CONNECTION DIAGRAMS

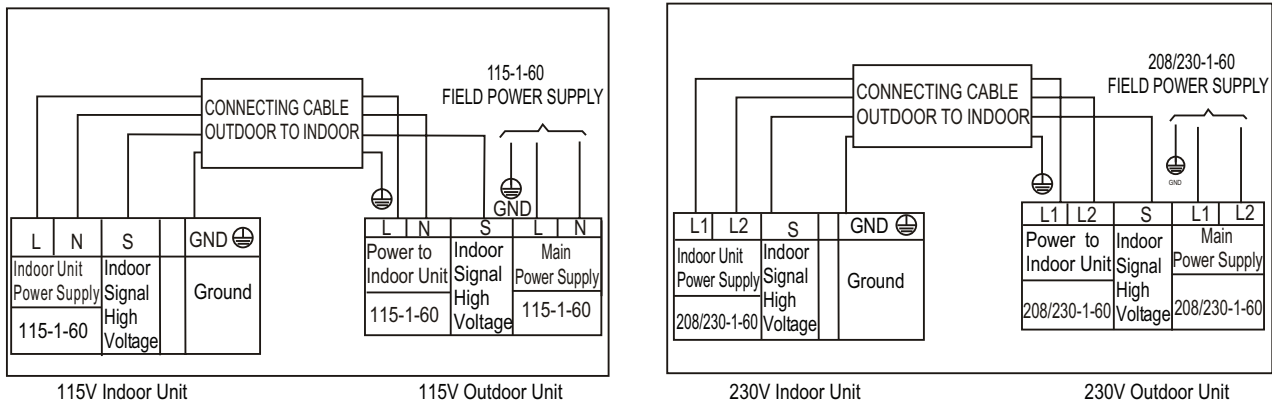

**Fig. 16 — Connection Diagrams**

**NOTES:**

1. Do not use the thermostat wire for any connection between indoor and outdoor units.
2. All connections between indoor and outdoor units must be as shown. The connections are sensitive to polarity and will result in a fault code.

# SYSTEM VACUUM AND CHARGE

**CAUTION**

**UNIT DAMAGE HAZARD**

Failure to follow this caution may result in equipment damage or improper operation.

Never use the system compressor as a vacuum pump.

Refrigerant tubes and the indoor coil should be evacuated using the recommended 500 microns deep vacuum method. The alternate triple evacuation method may be used if the procedure outlined below is followed.

**NOTE: Always break a vacuum with dry nitrogen.**

## Using Vacuum Pump

1. Completely tighten flare nuts A, B, C, D, connect the manifold gage charge hose to a charge port of the low side service valve (see Fig. 17).
2. Connect the charge hose to vacuum pump.
3. Fully open the low side of manifold gage (see Fig. 18).
4. Start the vacuum pump.
5. Evacuate using either the deep vacuum or the triple evacuation method.
6. After the evacuation is complete, fully close the low side of manifold gage and stop the vacuum pump operation.
7. The factory charge contained in the outdoor unit is good for up to 25 ft. (8 m) of line length. For refrigerant lines longer than 25 ft. (8 m), add refrigerant, up to the allowable length, as specified in the System Requirements section.
8. Disconnect the charge hose from the charge connection of the low side service valve.
9. Fully open service valves B and A.
10. Securely tighten the service valve caps.

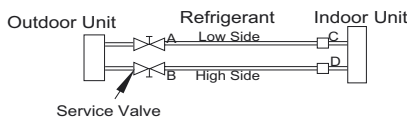

**Fig. 17 — Service Valve**

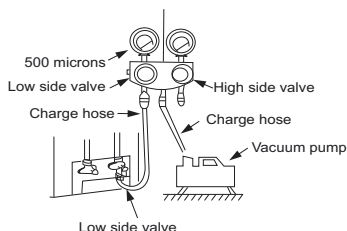

**Fig. 18 — Manifold**

## Deep Vacuum Method

The deep vacuum method requires a vacuum pump capable of pulling a vacuum of 500 microns and a vacuum gage capable of accurately measuring this vacuum depth. The deep vacuum method is the best way to assure a system is free of air and moisture (see Fig. 19).

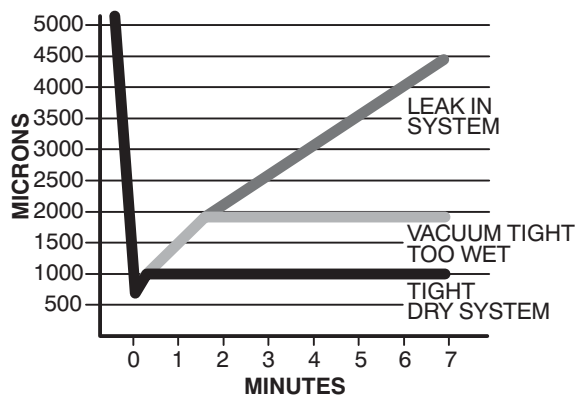

**Fig. 19 — Deep Vacuum Graph**

## Triple Evacuation Method

The triple evacuation method should only be used when the vacuum pump is only capable of pumping down to 28 in. of mercury vacuum and the system does not contain any liquid water.

Refer to Fig. 20 and proceed as follows:

1. Pump the system down to 28 in. of mercury and allow the pump to continue operating for an additional 15 minutes.
2. Close the service valves and shut off the vacuum pump.
3. Connect a nitrogen cylinder and regulator to the system and open until the system pressure is 2 psig.
4. Close the service valve and allow the system to stand for 1 hr. During this time, dry nitrogen can diffuse throughout the system absorbing moisture.
5. Repeat this procedure as indicated in Fig. 20. The system will then be free of any contaminants and water vapor.

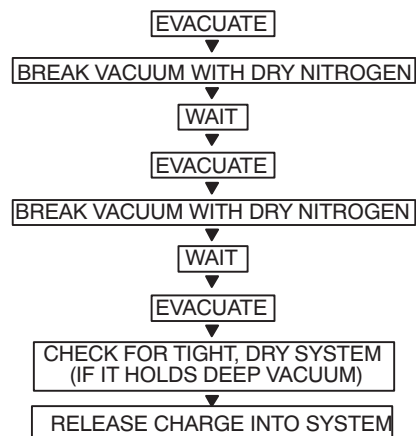

**Fig. 20 — Triple Evacuation Method**

## Final Tubing Check

**IMPORTANT: Ensure that the factory tubing on both the indoor and outdoor unit has not shifted during shipment. Ensure tubes are not rubbing against each other or any sheet metal. Pay close attention to the feeder tubes, making sure wire ties on feeder tubes are secure and tight.**

# START-UP

## Test Operation

Perform a test operation after completing a gas leak and electrical safety check. Review the indoor unit installation instructions and owner's manual for additional start up information.

## System Checks

1. Conceal the tubing where possible.
2. Make sure that the drain tube slopes downward along its entire length.
3. Ensure all tubing and connections are properly insulated.
4. Fasten the tubes to the outside wall, when possible.
5. Seal the hole through which the cables and tubing pass.

## Outdoor Unit

1. Are there unusual noises or vibrations during operation?

### **Explain the Following Items to the Customer (with the aid of the Owner's Manual):**

1. Explain care and maintenance.
2. Present the installation instructions to the customer.

# TROUBLESHOOTING

For ease of service, the systems are equipped with diagnostic code display LEDs on both the indoor and outdoor units. The outdoor diagnostic display are two LEDs (Red and Green) on the outdoor unit board and is limited to very few errors. The indoor diagnostic display is a combination of flashing LEDs on the display panel or the front of the unit.

There may be a few error codes displayed in the indoor unit that might relate to the outdoor unit's problems. If possible, always check the diagnostic codes displayed on the indoor unit first. The diagnostic codes displayed in the outdoor units are listed in Table 10.

**Table 10 — Unit Diagnostic Guides**

GREEN LED	RED LED	FAILURE MODE
On	X	Standby, normal
X	On	Operation, normal
On	On	High/Low voltage protection on compressor terminal
On	☆	EEPROM error
X	☆	The compressor speed is out of control
☆	On	Zero-crossing signal detection error; lack of phase; synchronization error
☆	X	IGBT or Module protection
☆	☆	Communication error

☆ = Flashing, X = Off

For additional diagnostic information, refer to the service manual.